



HYDRAULIC HOSE PRODUCTS



TABLE OF CONTENTS

TABLE OF CONTENTS

Technical Data

A1

Recommended Practices for Hydraulic Hose Assemblies - SAE J1273-2009	A2
Selection of Hose	A3
How to Measure Flextral Assemblies	A4
How to Measure Fitting Orientation	A5
Assembly of SAE 37° Flare Fittings Using “Flats Method” To Achieve Proper Torque	A6
Formulas and Conversion Factors for Fluid Power Use	A7
Pressure Conversion Factors	A8
Thread Identification Index	A9
How to Identify a Thread	A10
Thread Identification	A11

Hose

B1

Miscellaneous	B2
Pressure Washer	B6
Thermoplastic	B8
Hydraulic Braided	B15
Hydraulic Spiral	B23

Couplings

C1

Hose End Index	C2
E Series	C5
N Series	C34
V-VS Series	C57
C Series	C79
HA Series	C83
F Series	C85



TABLE OF CONTENTS

Couplings (continued) C1

P Series	C88
T Series	C93
AF Series	C109
TS Series	C118
Z-ZR Series	C119
J Series	C126
1R Series	C131
2R Series	C132
5R Series	C133

Adapters D1

Quick Reference Chart	D2
Tube and Pipe	D10
Flange	D17
Tube and Pipe	D22
O-Ring Boss	D59
BSP and Metric	D67
O-Ring Face Seal	D79
Flareless	D94

Accessories E1

Sleeving	E2
Plastic Wrap	E3
Steel Spring Guard/Fire Sleeving	E4
Flat Armor Guard	E5
Kits	E6



TABLE OF CONTENTS

TABLE OF CONTENTS

Accessories (continued)

E1

O-Rings/D-Rings	E7
StopFlex® Nipple Retention Systems	E8
StopFlex® Hose Bands	E9
Hose Handle Clamps & Velcro Straps	E10

Equipment

F1

FX17E & FX17A/17H	F2
FX17LWP	F3
FX21FBE “FatBoy” & FX21FBA/FBH	F4
FX21	F5
FX21E	F6
FX41 “The Boss”	F7
FX200	F8
FX300	F9
FX400	F10
FX1200	F11
Weatherhead Conversion Kits	F12
Reusable Coupling Press & Saws	F13
Hose Saws	F14
Tools	F15
Racks/Cabinets	F17

Index

G1

Parts Index	G2
-------------	----

TECHNICAL DATA

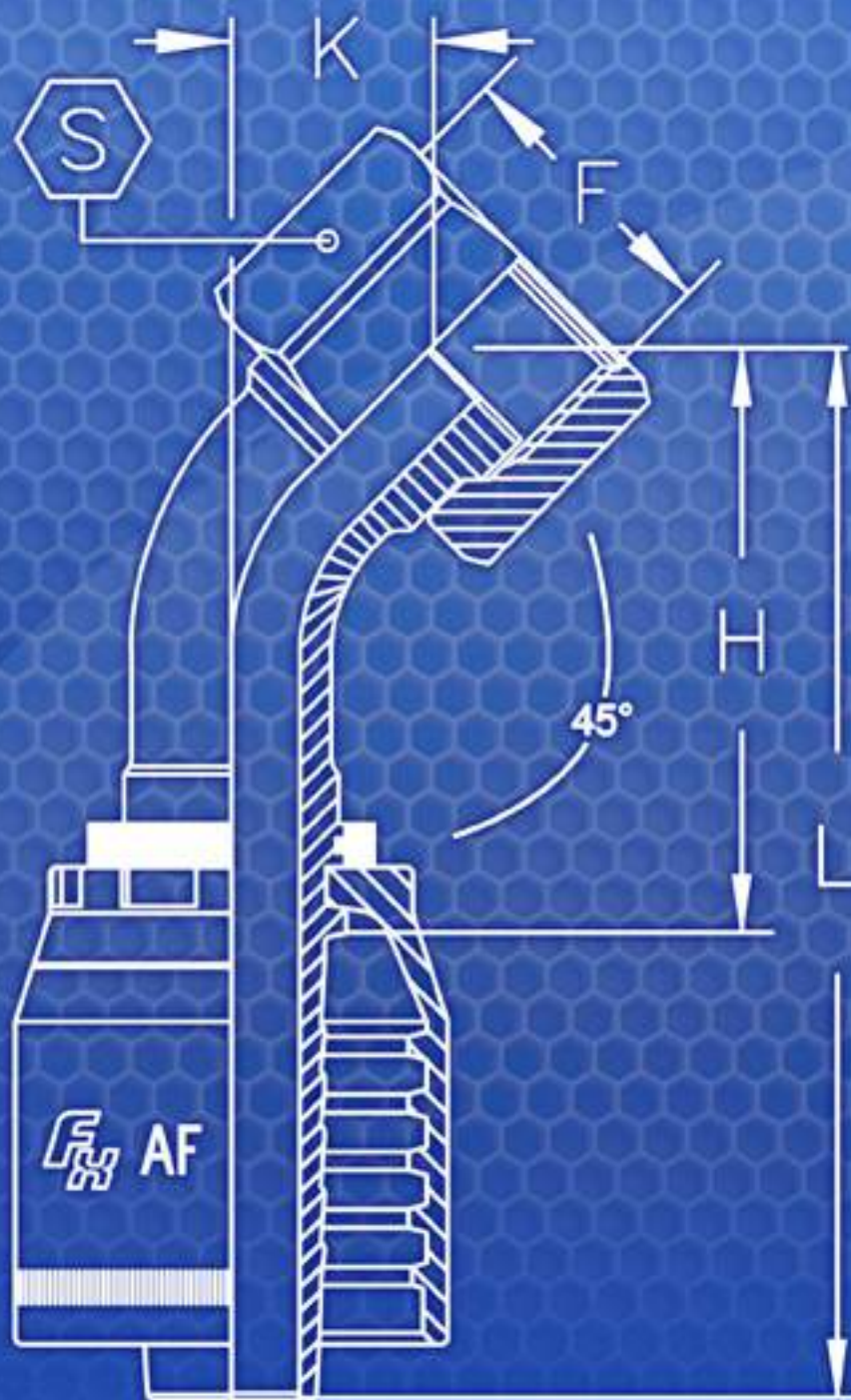

FLENTRAL

TECHNICAL DATA

Recommended Practices for Hydraulic Hose Assemblies - SAE J1273-2009

Foreword

The SAE Recommended Practices is intended as a guide to consider when selecting, routing, fabricating, installing, replacing, maintaining, and storing hose for fluid-power systems. It is subject to change to keep pace with experience and technical advances. For those new to hose use in fluid power systems, this guide outlines practices to note during each phase of system design and use. Experienced designers and users skilled in achieving proper results, as well as the less experienced, can use this outline as a list of considerations to keep in mind.

Fluid-power systems are complex and require extensive knowledge of both the system requirements and the various types of hose. Therefore, all inclusive, detailed, step by step instructions are not practical and are beyond the scope of this document. Less experienced designers and users who need more information can consult specialists such as hose suppliers and manufacturers. This guide can improve the communication process.

Safety Considerations

These recommended practices involve safety considerations; note these carefully during all phases of design and use of hose systems. Improper selection, fabrication, installation, or maintenance of hose and hose assemblies for fluid power systems may result in serious personal injury or property damage. These recommended practices can reduce the likelihood of component or system failure, thereby reducing the risk of injury or damage.

1. Scope - SAEJ1273 provides guidelines for selection, routing, fabrication, installation, replacement, maintenance, and storage of hose and hose assemblies for fluid-power systems. Many of these SAE Recommended Practices also may be suitable for other hoses and systems.

2. Reference

2.1 Applicable publications - The following publications form a part of this specification to the extent specified herein, Unless otherwise specified, the latest issue of SAE publications shall apply.

2.1.1 SAE publications - Available for SAE, 400 Commonwealth Drive, Warrendale, PA 15096-000

SAEJ343 - Test and Procedures for SAE 100 R Series Hydraulic Hose and Hose Assemblies
SAEJ514 - Hydraulic Tube Fittings

SAEJ517 - Hydraulic Hose
SAEJ 1927 - Cumulative Damage Analysis for Hydraulic Hose Assemblies

2.1.2 ISO publications - Available from ANSI, 11 West 42nd Street, New York, NY 10036-8002

ISO 3457 - Earth moving machinery - Guards and shields definitions and specifications.

3. Definitions

These explanations serve only to clarify this document and are not intended to stand alone. They are presented sequentially, with the former helping to explain the latter.

3.1 Fluid-power Energy transmitted and controlled using pressurized hydraulic fluids or compressed air.

3.2 Hose - flexible conductor. In this document, the term hose also may refer to a hose assembly with related accessories used in fluid power applications.

3.3 Hose fitting or fitting - connector which can be attached to the end of a hose.

3.4 Hose assembly - hose with hose fittings attached.

3.5 Hose failure - occurrence in which a hose stops meeting system requirements. 3.6 Hose service life - length of time a hose meets system requirements without needing replacement.

4. Safety considerations - listed in 4.1 to 4.7 are some potential conditions and situations that may lead to personal injury and/or property damage. This list is not necessarily all inclusive. Consider reasonable and feasible means, including those described in this section, to reduce the risk of injuries or property damage.

Training, including the information in this document, for operators, maintenance personnel, and other individuals working with hoses under pressure is encouraged.

4.1 Fluid injections - fine streams of escaping pressurized fluid can penetrate skin and enter a human body. These fluid injections may cause severe tissue damage and loss of limb. Consider various means to reduce the risk of fluid injections, particularly in areas normally occupied by operators. Consider careful routing, adjacent components, warnings, guards, shields, and training programs.

Relieve pressure before disconnecting hydraulic or other lines. Tighten all connections before applying pressure. Avoid contact with escaping fluids. Treat all leaks as though pressurized and hot enough to burn skin. Never use any part of your body to check a hose for leaks. If a fluid-injection accident occurs, see a doctor immediately. DO NOT DELAY OR TREAT AS A SIMPLE CUT! Any fluid injected into skin must be surgically removed within a few hours or gangrene may result. Doctors unfamiliar with this type of injury should consult a knowledgeable medical source.

4-2 Whipping hose - if a pressurized hose assembly blows apart, the fittings can be thrown off at high speed, and the loose hose can flail or whip with great force. This is particularly true in compressible-fluid systems. When the risk exists, consider guards and restraints to protect against injury.

4-3 Burns from conveyed fluids - fluid-power media may reach temperatures that can burn human skin. If there is risk of burns from escaping fluid, consider guards and shields to prevent injury, particularly in areas normally occupied by operators.

4-4 Fire and explosions from conveyed fluids - most fluid-power media, including fire-resistant hydraulic fluids, will burn under certain conditions. Fluids which escape from pressurized systems may form a mist or fine spray which can flash or explode upon contact with an ignition source. Consider selecting, guarding, and routing hose to minimize the risk of combustion (see Section 5 and ISO 3457).

4.5 Fire and explosions from static-electric discharge - fluid passing through hose can generate static electricity, resulting in static electric discharge. This may create sparks that can ignite system fluids or gases in the surrounding atmosphere.

When this potential exists, select hose specifically designed to carry the static-electric charge to ground.

Selection of Hose

System Type

The selection and installation of hoses must be in relation to pump pressure, operating cycle, inner diameters of pipes, and type of fluid.

Operating Pressure

Hose lines are rated for continuous operation at the maximum operating pressures specified for the hose.

Generally, the operating pressure is one fourth the hose minimum burst pressure, thus meeting the SAE recommended safety factor of 4 to 1.

Pressure Surges

Almost all hydraulic systems develop pressure surges which may exceed relief valve settings and affect the service life of hose and system components. In systems where surges are severe, select a hose that will increase the safety factor.

Conversely, in systems where surges are slight or non-existent, a smaller safety factor may be used.

Operating Temperatures

Operating temperatures specified refer to maximum temperature of the fluid or gases being conveyed (with peaks up to 300°F or 149°C). Continuous operation at or near maximum rated temperatures will materially reduce the service life of the hose.

Ambient Temperatures

Very high or low ambient (outside of hose) temperatures will affect cover and reinforcement materials, thus influencing the life of the hose.

Bend Radius

Recommended minimum bend radii are based on maximum operating pressures with no flexing of the hose.

Vibration and Flexing

Hose lines are designed to withstand maximum vibration and flexing.

Volumetric Expansion

Hose is normally manufactured with a neutral braid angle to reduce volumetric expansion.

Gaseous Fluid Systems

High pressure gaseous systems are very hazardous. Hose lines should be adequately protected from external shock and mechanical or chemical damage.

They should also be suitably protected to prevent whip-lash action in the event of failure for any reasons.

It is recommended to increase safety factor.

Hose Installation Guide

<p>Be sure to leave some slack to allow for changes in length under surge pressures (estimated at +2% to -4%)</p>	<p>Use angle adaptors to avoid sharp twists or bends</p>
<p>Allow for movement on flexing or vibrating installations to minimise flex failure and abrasion</p>	<p>Use 45° and 90° adaptors and fittings to improve routing</p>

Hose and Fitting Compatibility

SAE J517 hose from one manufacturer is usually not compatible with SAE J516 fittings supplied by another manufacturer. It is the responsibility of the fabricator to consult the manufacturer's written assembly instructions or the manufacturer directly before intermixing hose and fittings from two manufacturers. Similarly, assembly equipment from one manufacturer is usually not interchangeable with that of another manufacturer. It is the responsibility of the fabricator to consult the manufacturer's written instructions or the manufacturer directly for proper assembly equipment. Always follow the manufacturer's instructions for proper preparation and fabrication of hose assemblies.

TECHNICAL DATA

How to Measure Flextral Assemblies

Use to identify length of customer sample and for checking proper length of new hose assembly.

Unless otherwise specified, assembly length shall be the overall length measured from the extreme end of one connector to the extreme end of the other. O-ring face seal type connectors shall be measured from the sealing face. Where elbow connectors are used, measurement shall be to the centerline of the sealing surface of the elbow end (The sealing surface of female flared elbow connectors shall be the centerline of the outer end of the cone seat). See figures below.

Hold the assembly so that you can look along the length of the hose and with the fitting furthest away from you in the vertical position. Measure the angle between the vertical fitting and the one nearest to you in a clockwise direction. Relationship can then be expressed from 0° to 360°.

Method of measurement should be specified. Tolerances on assembly length shall be as in table below.

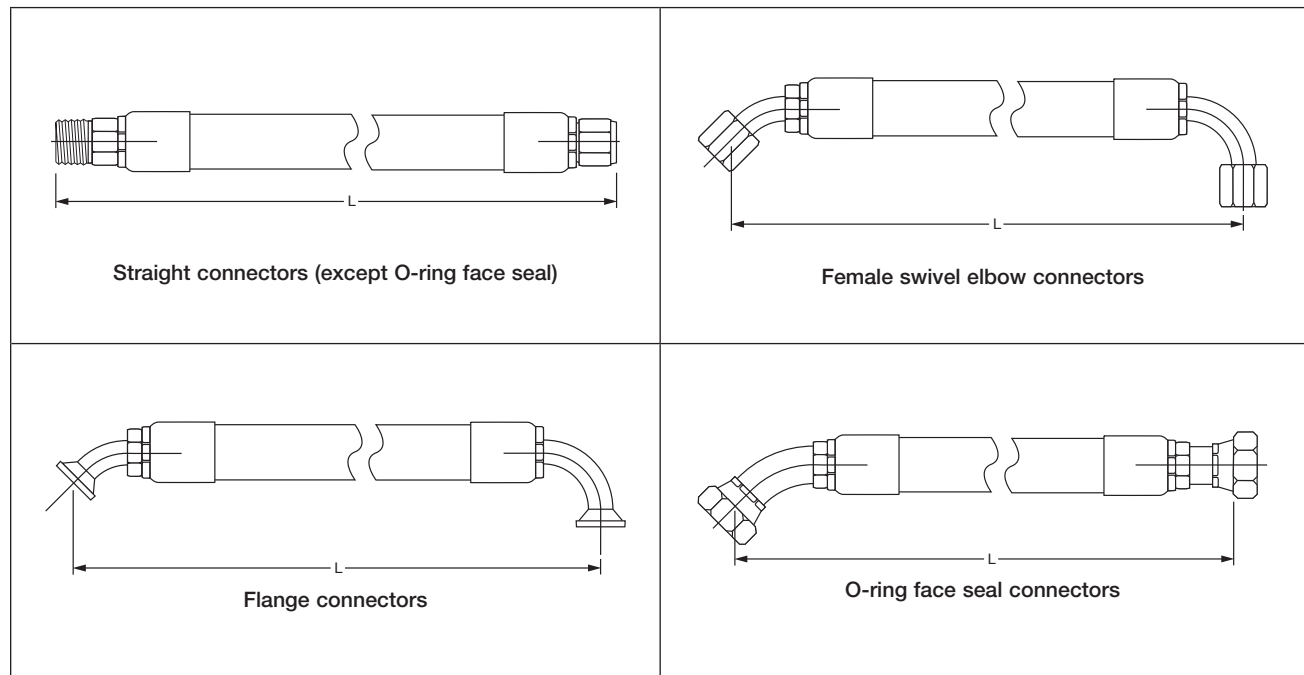

Assembly Length	Tolerances (decimal inch)	Tolerances (fraction inch)	Tolerances (mm)
Up through 12" (304.8 mm)	0.13	1/8	3.2
Over 12" through 18" (304.8 through 457.2 mm)	0.19	3/16	4.8
Over 18" through 36" (457.2 through 914.4 mm)	0.25	1/4	6.4
Over 36" (914.4 mm)	1%	1%	1%

Angular Relationships

Hold the assembly so that you can look along the length of the hose and with the fitting furthest away from you in the vertical position. Measure the angle between the vertical fitting and the one nearest to you in a clockwise direction. Relationship can then be expressed from 0° to 360°.

How to Measure Fitting Orientation

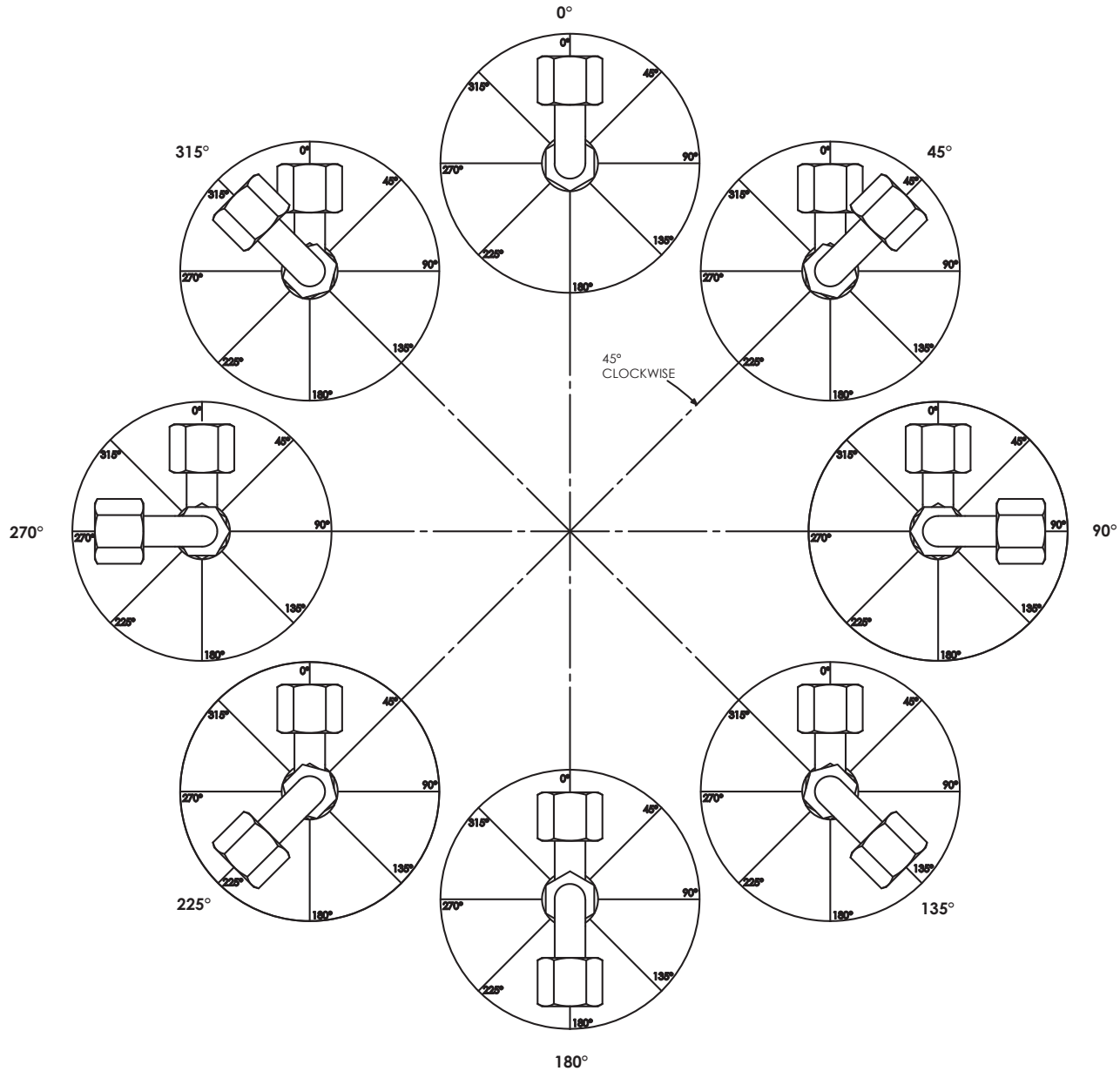

Orientation is determined by the number of degrees measured in a clockwise direction between the farthest fitting and the nearest fitting.

TECHNICAL DATA

Assembly of SAE 37° Flare Fittings Using “Flats Method” To Achieve Proper Torque

The “Flats Method” is the assembly method recommended by Flextral Engineering for trivalent (silver color) plated components. By using this method, the user can be assured the proper clamp load is applied to the flare connection regardless of the plating type.

A. Hand tighten the swivel nut to the mating male flare adapter. “Hand Tight” is described as the point where the swivel nut will no longer thread onto the mating connector when moderate torque is applied with the hand or fingers. When this is complete wiggle the swivel nut back and forth to insure full engagement has taken place.

B. Mark a line on one of the swivel nut hex flats and extend that line onto the hex of the tube adapter as shown.

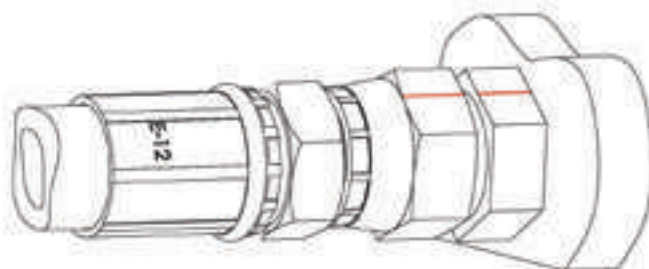

C. Using the proper wrench, turn the swivel nut to tighten. The nut is to be rotated clockwise the recommended number of hex flats as shown below and in the chart titled “Assembly Procedures – Flats Rotation”.

D. Note: a second wrench should be used to hold the coupling hex to prevent hose twist during assembly.

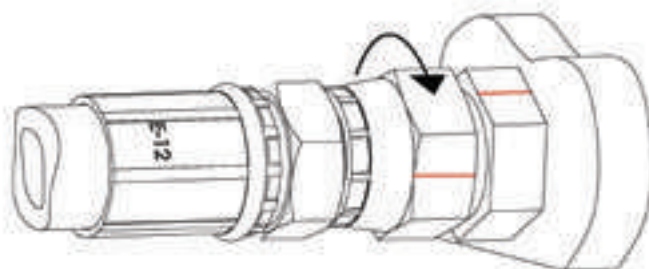

Assembly Procedures - Flats Rotation		
Size	Degrees of rotation	37° Machined Seat (hex flats)
-3	120	2
-4	120	2
-5	90	1-1/2
-6	90	1-1/2
-8	75	1-1/4
-10	60	1
-12	60	1
-16	60	1
-20	60	1
-24	60	1
-32	60	1

Formulas and Conversion Factors for Fluid Power Use

Quantity	Metric Units	U.S. Customary Units	From Metric to U.S. Units	From U.S. to Metric Units
Area	Square centimeters (<i>cm²</i>)	Square inches (<i>ln²</i>)	$cm^2 \times 0.155 = ln^2$	$ln^2 \times 6.452 = cm^2$
Length	Meters (<i>mt.</i>)	Feet (<i>ft.</i>)	$mt. \times 3.281 = ft.$	$ft. \times 0.305 = mt.$
Weight	Kilograms (<i>kg.</i>)	Pounds (<i>p</i>)	$kg. \times 2.2046 = p$	$p \times 0.4535 = kg.$
Volume	Cubic centimeters (<i>cm³</i>)	Cubic feet (<i>Cu.Ft.</i>)	$cm^3 \times 0.061 = Cu.Ft.$	$Cu.Ft. \times 16.39 = cm^3$
	Litres (<i>lt.</i>)	Gallons (<i>gal</i>)	$lt. \times 0.2541 = gal$	$gal \times 3.7 = 8 lt.$
Power	Kilowatts (<i>Kwh</i>)	Horsepower (<i>HP</i>)	$HP \times 0.7457 = Kwh$	$Kwh \times 1.3410 = HP$
Frequency	Hertz (<i>Hz</i>)	Cycles/second (<i>cps</i>)	$Hz = cps$	$cps = Hz$
Load	Meter kilograms (<i>Kgm.</i>)	Feet-pounds (<i>lbf</i>)	$Kgm. \times 7.233 = lbf$	$lbf \times 0.1383 = Kgm$
Pressure	Bar (<i>Bar</i>)	Pounds/sq.inches (<i>P.S.I.</i>)	$Bar \times 14.50 = P.S.I.$	$P.S.I. \times 0.0689 = Bar$
	Pascal (<i>Pa</i>)	Pounds/sq.inches (<i>P.S.I.</i>)	$Pa \times 0.145 = P.S.I.$	$P.S.I. \times 6.8948 = Pa$
	Mega Pascal (<i>MPa</i>)	Pounds/sq.inches (<i>P.S.I.</i>)	$MPa \times 145.0377 = P.S.I.$	$P.S.I. \times .0068948 = MPa$
	Atmospheres (<i>Atm.</i>)	Pounds/sq.inches (<i>P.S.I.</i>)	$Atm. \times 14.70 = P.S.I.$	$P.S.I. \times 0.0680 = Atm.$
Density	Gram/cubic centimeters (<i>gr./cm³</i>)	Pounds/cu.inches (<i>pci</i>)	$gr./cm^3 \times 0.03613 = pci$	$pci \times 27.68 = gr./cm^3$
Temperature	Degrees celsius °C	Degrees fahrenheit °F	$°C = (°F - 32)/1.8$	$°F = °C \times 1.8 + 32$

TECHNICAL DATA

Pressure Conversion Factors

BAR to P.S.I.			
Bar	K/pascals	Kg/cm ²	PSI
1	100	1.02	14.5
2	200	2.04	29.0
3	300	3.06	43.5
4	400	4.08	58.0
5	500	5.10	72.5
6	600	6.12	87.0
7	700	7.14	101.5
8	800	8.16	116.0
9	900	9.18	130.5
10	1,000	10.20	145.0
20	2,000	20.40	290.1
30	3,000	30.60	435.1
40	4,000	40.80	580.2
50	5,000	51.00	725.2

BAR to P.S.I.			
Bar	K/pascals	Kg/cm ²	PSI
60	6,000	61.20	870.2
70	7,000	71.40	1,015.3
80	8,000	81.60	1,160.3
90	9,000	91.80	1,305.3
100	10,000	102.00	1,450
200	20,000	204.00	2,901
300	30,000	306.00	4,351
400	40,000	408.00	5,802
600	60,000	612.00	8,702
700	70,000	714.00	10,153
800	80,000	816.00	11,603
900	90,000	918.00	13,053
1.000	100,000	1,020.00	14,504
2.000	200,000	2,040.00	29,008
3.000	300,000	3,060.00	43,511

PSI to BAR			
PSI	K/pascals	Kg/cm ²	BAR
10	68.9	0.71	0.7
20	137.9	1.41	1.4
30	206.8	2.11	2.1
40	275.8	2.82	2.8
50	344.7	3.52	3.4
60	413.7	4.22	4.1
70	482.6	4.93	4.8
80	551.6	5.63	5.5
90	620.5	6.63	6.2
100	689	7.04	6.9
200	1,379	14.07	13.8
300	2,068	21.10	20.7
400	2,758	28.13	27.6
500	3,447	35.16	34.5
600	4,137	42.19	41.4

PSI to BAR			
PSI	K/pascals	Kg/cm ²	BAR
700	4,826	49.22	48.3
800	5,516	56.25	55.2
900	6,205	63.28	62.1
1,000	6,895	70.31	68.9
2,000	13,790	140.62	137.9
3,000	20,684	210.93	206.8
4,000	27,579	281.23	275.8
5,000	34,474	351.54	344.7
6,000	41,369	471.85	413.7
7,000	48,263	492.15	482.6
8,000	55,158	562.46	551.6
9,000	62,053	632.77	620.5
10,000	68,948	703.07	689
20,000	137,895	1,406.14	1,379
30,000	206,843	2,109.21	2,068
40,000	275,790	2,812.28	2,758

Thread Identification

	Page
How to Identify a Thread	A12
British Standard Pipe Taper - (BSPT) - Male	A13
British Standard Pipe Parallel - (BSPP) - Male	A13
British Standard Pipe Parallel - (BSPP) - Female	A14
British Standard Pipe Taper - (BSPT) - Female	A14
British Pipe Parallel - (BSPP) - Female - (Flextral nut)	A14
Joint Industry Council - (JIC) - Male	A15
Joint Industry Council - (JIC) - Female (crimped nut)	A15
Joint Industry Council - (JIC) - Female - (Flextral nut)	A16
Unified National 'O' Ring - (UNO) - Male	A16
Society of Automotive Engineers - (SAE) - Male	A17
Society of Automotive Engineers - (SAE) - Inverted Flare Male	A17
Society of Automotive Engineers - (SAE) - Inverted Flare Female	A18
National Pipe Taper Fuel - (NPTF) - Male	A18
National Pipe Straight Mechanical - (NPSM) - Female	A18
Metric 'DKL' Light Series - Male	A19
Metric 'DKL' Light Series - Female (Globe Seal)	A19
Metric 'DKS' Heavy Series - Male	A20
Metric 'DKS' Heavy Series - Female (Globe and Ring Seal)	A20
Japanese Industrial Standard - Metric - Male (Komatsu)	A21
Japanese Industrial Standard - Metric - Female (Komatsu)	A21
Japanese Industrial Standard - (BSPP) - Male	A22
Japanese Industrial Standard - (BSPP) - Female	A22
Staple Lock - Male	A23
Staple Lock - Female	A23
High Pressure Staple Lock - Male	A23
High Pressure Staple Lock - Female	A24
Code 61 Flange - SAE J518	A24
Code 62 Flange - SAE J518	A24
Caterpillar® Type Flange	A25
Code 61 Split Flange	A25
Code 62 Split Flange	A25
'O' Ring Face Seal - Male	A26
'O' Ring Face Seal - Female	A26
GAZ French Metric - Male	A26
GAZ French Metric - Female	A27
Kobelco Metric - Male	A27
Kobelco Metric - Female	A27

TECHNICAL DATA

How to Identify a Thread

Foreword

There are many different threads by which fluid connectors are attached to a system. These come under a variety of standards, some of which are set out below. It is obviously crucial to know what standard/style the thread or attachment is so the appropriate fluid connector components can be selected to complete or repair a circuit.

For easy identification there are four main points to look for.

1. The general appearance of the fitting, or how it is laid out. Is the thread tapered or straight? Is the seat concave or convex? Obviously the complementary or matching fitting will be an opposite of the other.
2. The pitch of the thread. Some thread styles look very similar to each other, only the thread pitch differs. This is an important check to make, as if the incorrect fitting is screwed in, damage to the other thread may occur, weakening it or causing irreparable damage.
3. The angle of the sealing area. As above, some styles will look very much alike. Some even have the same thread dimension and pitch, but the seal angle is different. This is an important thing to check as the sealing of the connection is reliant on this area.
4. The thread diameter or the size of the connection. The tables of sizes for the various styles will have a dimension as per the standard. Often threads will not match this dimension exactly as there are matching tolerances, but the correct size will be obvious.
5. Pressures indicated are relative to the appropriate standard for the thread indicated. There are two parts to any connection and the pressure can only be as good as the weaker one. Any hose, tube or other item in the circuit which is one of a lower working pressure will dictate the maximum pressure of the circuit.



With these points in mind, and by following the steps, the correct style and standard will be easily determined. But be careful, by missing one you may get it wrong.

Thread Identification

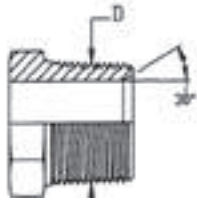
British Standard Pipe Taper - (BSPT) - Male

 <p>Applicable Standards Thread Form: AS 1722.1-1975, ISO 7 Materials Available: Low Carbon Steel 316 (Stainless Steel) GB12361-12362 Part 11 (Drop Forged)</p>	Pipe Size	Dash Size	Nominal Thread Size & Pitch	Max Working Pressure		Thread OD 'D' on Diagram	
				Bar	PSI	mm	in
	1/8	02	1/8 - 28	630	9,000	9.73	0.383
	1/4	04	1/4 - 19	630	9,000	13.16	0.518
	3/8	06	3/8 - 19	560	8,000	16.67	0.656
	1/2	08	1/2 - 14	430	6,250	20.96	0.825
	5/8*	10	5/8 - 14	350	5,000	22.91	0.902
	3/4	12	3/4 - 14	350	5,000	26.45	1.041
	1	16	1 - 11	280	4,000	33.25	1.309
	1 1/4	20	1 1/4 - 11	245	3,500	41.91	1.650
1 1/2	24	1 1/2 - 11	210	3,000	47.81	1.882	
2	32	2 - 11	210	3,000	59.62	2.347	

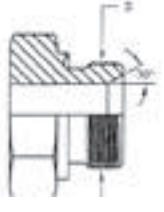
British Standard Pipe Parallel - (BSPP) - Male

 <p>Applicable Standards Thread Form: AS 1722.2-1992, ISO 228 Seal: DIN 3852 Part 2 Form E Materials Available: Low Carbon Steel 316 Stainless Steel GB12361-12362 Part II (Drop Forged)</p>	 <p>Applicable Standards Thread Form: AS 1722.2-1992, ISO 228 Seal: DIN 3852 Part 2 Form D Materials Available: Low Carbon Steel GB12361-12362 Part II (Drop Forged)</p>	 <p>Applicable Standards Thread Form: AS 1722.2-1992, ISO 228 Seal: DIN 3852 Part 2 Form H Materials Available: Low Carbon Steel GB12361-12362 Part II (Drop Forged)</p>
--	--	--

Pipe Size	Dash Size	Correct Torque (Ft-Lb)	Nominal Thread Size & Pitch	Max Working Pressure				Thread OD 'D' on Diagram	
				Bar Fixed	Bar Adj	PSI Fixed	PSI Adj	mm	in
1/8	02	15	1/8 - 28	630	350	9,000	5,000	9.73	0.383
1/4	04	37	1/4 - 19	630	350	9,000	5,000	13.16	0.518
3/8	06	59	3/8 - 19	560	280	8,000	4,000	16.67	0.656
1/2	08	74	1/2 - 14	430	280	6,250	4,000	20.96	0.825
5/8*	10	89	5/8 - 14	350	280	5,000	4,000	22.91	0.902
3/4	12	148	3/4 - 14	350	245	5,000	3,500	26.45	1.041
1	16	280	1 - 11	280	245	4,000	2,500	33.25	1.309
1 1/4	20	369	1 1/4 - 11	245	140	3,500	2,000	41.91	1.650
1 1/2	24	443	1 1/2 - 11	210	140	3,000	2,000	47.81	1.882
2	32	553	2 - 11	210	105	3,000	1,500	59.62	2.347

*5/8 Size is not subject to Standards

TECHNICAL DATA

Thread Identification

British Standard Pipe Parallel - (BSPP) - Female

Taper - (BSPT) - Female



Applicable Standards
 Thread Form: AS 1722.2-1992, ISO 228
 Materials Available: Low Carbon Steel
 GB12361-12362 Part II (Drop Forged) 316
 Stainless Steel



Applicable Standards
 Thread Form: AS 1722.2-1992, ISO 228
 Sealing Area: DIN 3852 Part 2 Form X



Applicable Standards
 Thread Form: AS 1722.2-1992, ISO 228
 Materials Available: Low Carbon Steel
 GB12361-12362 Part II (Drop Forged) 316
 Stainless Steel

Pipe Size	Dash Size	Correct Torque (Ft-Lb)	Nominal Thread Size & Pitch	Max Working Pressure		Thread ID 'D' on Diagram	
				Bar	PSI	mm	in
1/8	02	15	1/8 - 28	350	5,000	8.59	0.338
1/4	04	37	1/4 - 19	630	9,000	11.46	0.451
3/8	06	59	3/8 - 19	560	8,000	14.96	0.589
1/2	08	74	1/2 - 14	430	6,250	18.65	0.734
5/8*	10	89	5/8 - 14	380	5,500	20.60	0.811
3/4	12	148	3/4 - 14	350	5,000	24.13	0.950
1	16	280	1 - 11	280	4,000	30.30	1.193
1 1/4	20	369	1 1/4 - 11	245	3,500	38.97	1.534
1 1/2	24	443	1 1/2 - 11	210	3,000	44.86	1.766
2	32	553	2 - 11	210	3,000	56.67	2.231

*5/8" Size is not subject to Standards

British Pipe Parallel - (BSPP) - Female - (Flextral nut)

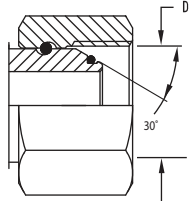

Applicable Standards
 Thread Form: AS 1722.2-1992, ISO 228
 Materials Available: Low Carbon Steel
 GB12361-12362 Part II (Drop Forged) 316
 Stainless Steel

Pipe Size	Dash Size	Correct Torque (Ft-Lb)	Nominal Thread Size & Pitch	Max Working Pressure		Thread OD 'D' on Diagram	
				Bar	PSI	mm	in
3/4	12	148	3/4 - 14	420	6,000	24.13	0.950
1	16	280	1 - 11	420	6,000	30.30	1.193
1 1/4	20	369	1 1/4 - 11	345	5,000	38.97	1.534
1 1/2	24	443	1 1/2 - 11	345	5,000	44.86	1.766
2	32	553	2 - 11	345	5,000	56.67	2.231

Thread Identification

Joint Industry Council - (JIC) - Male

Dash Size	Nominal Tube Size in	Correct Torque (Ft-Lb)	Nominal Thread Size & Pitch	Max Working Pressure		Thread OD 'D' on Diagram	
				Bar	PSI	mm	in
				02	1/8	11	5/16 - 24
03	3/16	11	3/8 - 24	-	-	9.65	0.380
04	1/4	11	7/16 - 20	595	8,500	11.07	0.436
05	5/16	18	1/2 - 20	595	8,500	12.70	0.500
06	3/8	26	9/16 - 18	490	7,000	14.25	0.561
08	1/2	44	3/4 - 16	420	6,000	19.00	0.748
10	5/8	59	7/8 - 14	385	5,500	22.17	0.873
12	3/4	89	1 1/16 - 12	280	4,000	26.95	1.061
16	1	111	1 5/16 - 12	245	3,500	33.30	1.311
20	1 1/4	133	1 5/8 - 12	245	3,500	41.22	1.623
24	1 1/2	166	1 7/8 - 12	140	2,000	47.57	1.873
32	2	258	2 1/2 - 12	87	1,250	63.45	2.498

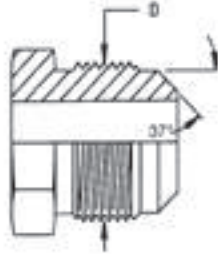

Applicable Standards
 Thread Form: SAE J514
 Materials Available: Low Carbon Steel 316 (Stainless Steel)
 GB 12361 - 12362 Part II (Drop Forged)

Joint Industry Council - (JIC) - Female (crimped nut)

Dash Size	Nominal Tube Size in	Correct Torque (Ft-Lb)	Nominal Thread Size & Pitch	Max Working Pressure		Thread OD 'D' on Diagram	
				Bar	PSI	mm	in
				02	1/8	11	5/16 - 24
03	3/16	11	3/8 - 24	420	6,000	8.63	0.340
04	1/4	11	7/16 - 20	420	6,000	10.00	0.394
05	5/16	18	1/2 - 20	420	6,000	11.60	0.457
06	3/8	26	9/16 - 18	350	5,000	13.00	0.512
08	1/2	44	3/4 - 16	315	4,500	17.60	0.693
10	5/8	59	7/8 - 14	280	4,000	20.50	0.807
12	3/4	89	1 1/16 - 12	280	4,000	25.00	0.985
16	1	111	1 5/16 - 12	207	3,000	31.30	1.233
20	1 1/4	133	1 5/8 - 12	140	2,000	39.20	1.544
24	1 1/2	166	1 7/8 - 12	105	1,500	45.60	1.796
32	2	258	2 1/2 - 12	80	1,250	61.50	2.422



Applicable Standards
 Thread Form: SAE J514
 Materials Available: Low Carbon Steel 316 (Stainless Steel) GB 12361 - 12362 Part II (Drop Forged)



TECHNICAL DATA

Thread Identification

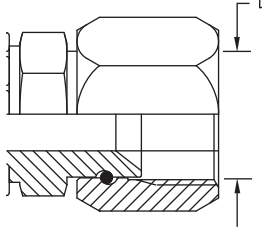
Joint Industry Council - (JIC) - Female - (wire nut)

 <p>Applicable Standards Thread Form: SAE J514 Materials Available: Low Carbon Steel 316 (Stainless Steel) GB 12361 - 12362 Part II (Drop Forged)</p>	Dash Size	Nominal Tube Size in	Correct Torque (Ft-Lb)	Nominal Thread Size & Pitch	Max Working Pressure		Thread OD 'D' on Diagram	
					Bar	PSI	mm	in
	12	3/4	89	1 1/16 - 12	350	6,000	25.00	0.985
	14	7/8	98	1 3/16 - 12	350	6,000	28.09	1.106
	16	1	111	1 5/16 - 12	280	5,400	31.30	1.233
	20	1 1/4	133	1 5/8 - 12	210	4,600	39.20	1.544
	24	1 1/2	166	1 7/8 - 12	190	4,100	45.60	1.796
	32	2	258	2 1/2 - 12	175	3,600	61.50	2.422

Unified National 'O' Ring - (UNO) - Male

 <p>Applicable Standards Thread Form: SAE J514 Materials Available: Low Carbon Steel</p>	 <p>Applicable Standards Thread Form: SAE J514 Materials Available: Low Carbon Steel</p>								
Dash Size	Nominal Tube Size in	Correct Torque (Ft-Lb)	Nominal Thread Size & Pitch	Max Working Pressure				Thread OD 'D' on Diagram	
				Bar Fixed	Bar Adj	PSI Fixed	PSI Adj	mm	in
02	1/8	11	5/16 - 24	525	315	7,500	4,500	7.87	0.310
03	3/16	11	3/8 - 24	525	315	7,500	4,500	9.65	0.380
04	1/4	11	7/16 - 20	525	315	7,500	4,500	11.07	0.436
05	5/16	18	1/2 - 20	525	315	7,500	4,500	12.70	0.500
06	3/8	26	9/16 - 18	525	280	7,500	4,000	14.25	0.561
08	1/2	44	3/4 - 16	525	280	7,500	4,000	19.00	0.748
10	5/8	59	7/8 - 14	525	280	7,500	4,000	22.17	0.873
12	3/4	89	1 1/16 - 12	350	245	5,000	3,500	26.95	1.061
16	1	111	1 5/16 - 12	315	175	4,500	2,500	33.30	1.311
20	1 1/4	133	1 5/8 - 12	280	140	4,500	2,000	41.22	1.623
24	1 1/2	166	1 7/8 - 12	245	140	3,500	2,000	47.57	1.873
32	2	258	2 1/2 - 12	140	70	2,000	1,000	63.45	2.498

Thread Identification

Society of Automotive Engineers - (SAE) - Male

Dash Size	Nominal Tube Size (Inches)	Nominal Thread Size & Pitch	Max Working Press				Thread OD 'D' on Diagram	
			Steel Bar	Brass Bar	Steel PSI	Brass PSI	mm	in
02	1/8	5/16 - 24	280	245	4,000	3,500	7.87	0.310
03	3/16	3/8 - 24	280	225	4,000	3,250	9.65	0.380
04	1/4	7/16 - 20	245	210	3,500	3,000	11.07	0.436
05	5/16	1/2 - 20	245	210	3,500	3,000	12.70	0.500
06	3/8	5/8 - 18	245	210	3,500	3,000	15.85	0.624
08	1/2	3/4 - 16	245	210	3,500	3,000	19.00	0.748
10	5/8	7/8 - 14	210	190	3,000	2,750	22.17	0.873
12	3/4	1 1/16 - 12	175	-	2,500	-	26.95	1.061
14	7/8	1 1/4 - 12	175	-	2,500	-	29.46	1.160
16	1	1 3/8 - 12	175	-	2,500	-	35.05	1.290

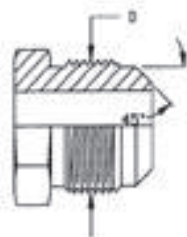

Applicable Standards

Thread Form: SAE J512

Materials Available: Low Carbon Steel
352 DR Brass Alloy GB 12361-12362 Part II (Drop Forged)

Society of Automotive Engineers - (SAE) - Inverted Flare Male

Dash Size	Nominal Tube Size (inches)	Nominal Thread Size & Pitch	Max Working Pressure		Thread OD 'D' on Diagram	
			Bar Fixed	PSI Fixed	mm	in
02	1/8	5/16 - 28	210	3,000	7.87	0.310
03	3/16	3/8 - 24	210	3,000	9.65	0.380
04	1/4	7/16 - 24	190	2,750	11.07	0.436
05	5/16	1/2 - 20	175	2,500	12.70	0.500
06	3/8	5/8 - 18	155	2,250	15.85	0.624
07	7/16	1 1/16 - 18	155	2,250	17.46	0.687
08	1/2	3/4 - 18	140	2,000	19.00	0.748
10	5/8	7/8 - 18	140	2,000	22.17	0.873
12	3/4	1 1/16 - 16	105	1,500	26.95	1.061

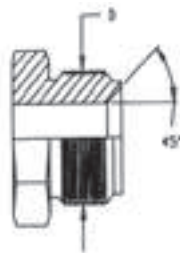

Applicable Standards

Thread Form: SAE J512

Materials Available: Low Carbon Steel
352 DR Brass Alloy

Adaptor Version

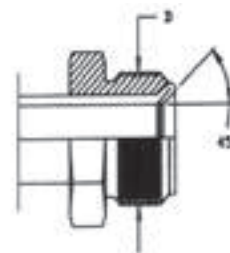

Applicable Standards

Thread Form: SAE J512

Materials Available: Low Carbon Steel
352 DR Brass Alloy

Tube Version

TECHNICAL DATA

Thread Identification

Society of Automotive Engineers - (SAE) - Inverted Flare Female

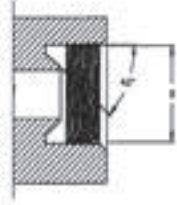
 Applicable Standards Thread Form: SAE J512 Materials Available: 352 DR Brass Alloy	Dash Size	Nominal Tube Size (Inches)	Nominal Thread Size & Pitch	Brass		Thread ID 'D' on Diagram	
				Bar	(PSI)	mm	in
	02	1/8	5/16 - 28	210	3,000	6.85	0.270
03	3/16	3/8 - 24	210	3,000	8.63	0.340	
04	1/4	7/16 - 24	190	2,750	10.00	0.394	
05	5/16	1/2 - 20	175	2,500	11.60	0.457	
06	3/8	5/8 - 18	155	2,250	14.70	0.579	
07	7/16	1 1/16 - 18	155	2,250	15.70	0.618	
08	1/2	3/4 - 18	140	2,000	17.60	0.693	
10	5/8	7/8 - 18	140	2,000	22.10	0.870	
12	3/4	1 1/16 - 16	105	1,500	25.30	0.996	

National Pipe Taper Fuel - (NPTF)

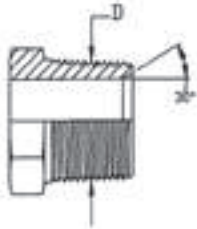
 Applicable Standards Thread Form: SAE J476 Materials Available: Low Carbon Steel 316 (Stainless Steel) GB12361-12362 Part II (Drop Forged)	Pipe Size	Dash Size	Nominal Thread Size & Pitch	Max Working Pressure		Thread OD 'D' on Diagram	
				Bar	PSI	mm	in
	1/8	02	1/8 - 27	830	12,000	10.32	0.406
1/4	04	1/4 - 18	830	12,000	13.89	0.546	
3/8	06	3/8 - 18	690	10,000	17.06	0.671	
1/2	08	1/2 - 14	690	10,000	21.43	0.843	
3/4	12	3/4 - 14	520	7,500	26.98	1.062	
1	16	1 - 11 1/2	450	6,500	33.33	1.312	
1 1/4	20	1 1/4 - 11 1/2	350	5,000	42.46	1.671	
1 1/2	24	1 1/2 - 11 1/2	210	3,000	48.42	1.906	
2	32	2 - 11 1/2	175	2,500	60.32	2.375	

National Pipe Straight Mechanical - (NPSM)

 Applicable Standards Thread Form: SAE J476 Materials Available: Low Carbon Steel 316 (Stainless Steel) GB12361-12362 Part II (Drop Forged)	Pipe Size	Dash Size	Nominal Thread Size & Pitch	Max Working Pressure		Thread ID 'D' on Diagram	
				Bar	PSI	mm	in
	1/8	02	1/8 - 27	520	7,500	9.12	.359
1/4	04	1/4 - 18	480	7,000	11.91	.468	
3/8	06	3/8 - 18	420	6,000	15.08	.593	
1/2	08	1/2 - 14	350	5,000	19.05	.750	
3/4	12	3/4 - 14	280	4,000	24.21	.953	
1	16	1 - 11 1/2	210	3,000	30.56	1.203	
1 1/4	20	1 1/4 - 11 1/2	175	2,500	38.89	1.531	
1 1/2	24	1 1/2 - 11 1/2	140	2,000	45.24	1.781	
2	32	2 - 11 1/2	140	2,000	57.15	2.250	

Thread Identification

Metric 'DKL' Light Series - Male

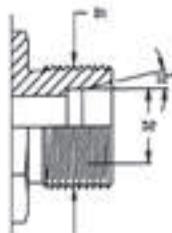
 Applicable Standards Thread Form: DIN 2353, DIN 3861, DIN 3901, DIN 3902 Materials Available: Low Carbon Steel 316 (Stainless Steel) GB 12361 - 12362 Part II (Drop Forged)	Dash Size	Nominal Tube Size 'D2' mm	Correct Torque (Ft-Lb)	Nominal Thread Size & Pitch	Max Working Pressure DIN 2401 pt I		Thread OD 'D1' on Diagram	
					Bar	PSI	mm	inch
	-12	6	18	M12 - 1.5	315	4,500	11.8	0.46
-14	8	26	M14 - 1.5	315	4,500	13.8	0.54	
-16	10	30	M16 - 1.5	280	4,000	15.8	0.62	
-18	12	33	M18 - 1.5	280	4,000	17.8	0.70	
-22	15	44	M22 - 1.5	210	3,000	21.8	0.86	
-26	18	66	M26 - 1.5	210	3,000	25.8	1.02	
-30	22	89	M30 - 2.0	155	2,250	29.8	1.17	
-36	28	118	M36 - 2.0	155	2,250	35.8	1.41	
-45	35	170	M45 - 2.0	155	2,250	44.8	1.76	
-52	42	207	M52 - 2.0	100	1,450	51.8	2.04	

Metric 'DKL' Light Series - Female (Globe Seal)

 Applicable Standards Thread Form: DIN 2353 DIN 3861 DIN 3901 DIN 3902 Materials Available: Low Carbon Steel 316 (Stainless Steel) GB 12361 - 12362 Part II (Drop Forged)	Dash Size	Nominal Tube Size 'D2' mm	Correct Torque (Ft-Lb)	Nominal Thread Size & Pitch	Max Working Pressure DIN 2401 pt I		Thread OD 'D1' on Diagram	
					Bar	PSI	mm	inch
	-12	6	18	M12 - 1.5	245	3,500	10.5	0.41
-14	8	26	M14 - 1.5	245	3,500	12.5	0.49	
-16	10	30	M16 - 1.5	245	3,500	14.5	0.57	
-18	12	33	M18 - 1.5	245	3,500	16.5	0.65	
-22	15	44	M22 - 1.5	245	3,500	20.5	0.81	
-26	18	66	M26 - 1.5	155	2,250	24.5	0.96	
-30	22	89	M30 - 2.0	155	2,250	28.0	1.10	
-36	28	118	M36 - 2.0	100	1,450	34.0	1.34	
-45	35	170	M45 - 2.0	100	1,450	43.0	1.69	
-52	42	207	M52 - 2.0	100	1,450	50.0	1.97	



TECHNICAL DATA

Thread Identification

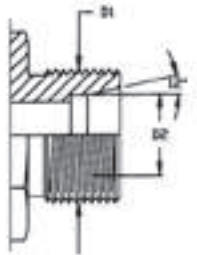
Metric 'DKS' Heavy Series - Male w/O'Ring

 <p>Applicable Standards Thread Form: DIN 2353, DIN 3861, DIN 3901, DIN 3902 Materials Available: Low Carbon Steel 316 (Stainless Steel) GB 12361 - 12362 Part II (Drop Forged)</p>	Dash Size	Nominal Tube Size 'D2' mm	Correct Torque (Ft-Lb)	Nominal Thread Size & Pitch	Max Working Pressure DIN 2401		Thread OD 'DI' on Diagram	
					Bar	PSI	mm	inch
	-14	6	33	M14 - 1.5	630	9,000	13.8	0.54
	-16	8	41	M16 - 1.5	420	6,000	15.8	0.62
	-18	10	52	M18 - 1.5	420	6,000	17.8	0.70
	-20	12	59	M20 - 1.5	420	6,000	19.8	0.78
	-22	14	74	M22 - 1.5	420	6,000	21.8	0.86
	-24	16	89	M24 - 1.5	420	6,000	23.8	0.94
	-30	20	125	M30 - 2.0	420	6,000	29.8	1.17
	-36	25	229	M36 - 2.0	315	4,500	35.8	1.41
-42	30	243	M42 - 2.0	315	4,500	44.8	1.76	
-52	38	332	M52 - 2.0	315	4,500	51.8	2.04	

Metric 'DKS' Heavy Series - Female (Globe and Ring Seal)

 <p>Applicable Standards Thread Form: DIN 2353 DIN 3861 DIN 3901 DIN 3902 Materials Available: Low Carbon Steel 316 (Stainless Steel) GB12361 - 12362 Part II (Drop Forged)</p>				 <p>Applicable Standards Thread Form: DIN 2353 DIN 3861 DIN 3901 DIN 3902 Materials Available: Low Carbon Steel 316 (Stainless Steel) GB 12361 - 12362 Part II (Drop Forged)</p>			
Dash Size	Nominal Tube Size 'D2'(mm)	Correct Torque (Ft-Lb)	Nominal Thread Size & Pitch	Max Working Pressure DIN 2401 Part 1		Thread OD 'DI' on Diagram	
				Bar	PSI	mm	inch
-14	6	33	M14 - 1.5	630	9,000	12.5	0.49
-16	8	41	M16 - 1.5	400	5,750	14.5	0.57
-18	10	52	M18 - 1.5	400	5,750	16.5	0.65
-20	12	59	M20 - 1.5	400	5,750	18.5	0.73
-22	14	74	M22 - 1.5	400	5,750	20.5	0.81
-24	16	89	M24 - 1.5	400	5,750	22.5	0.96
-30	20	125	M30 - 2.0	245	3,500	28.0	1.10
-36	25	229	M36 - 2.0	245	3,500	34.0	1.34
-42	30	243	M42 - 2.0	245	3,500	40.0	1.69
-52	38	332	M52 - 2.0	245	3,500	50.0	1.97

Thread Identification

Japanese Industrial Standard - Metric - Male (Komatsu)

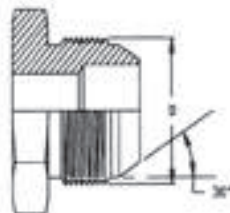
 <p>Applicable Standards Thread Form: Materials Available: Low Carbon Steel GB12361-12362 Part II (Drop Forged)</p>	Dash Size	Nominal Tube Size		Thread Size & Pitch	Thread OD 'D' on Diagram	
		in	mm		mm	in
	12			12 - 1.5	12	0.472
	14	1/4	6.4	14 - 1.5	14	0.551
	16			16 - 1.5	16	0.629
	18	3/8	10	18 - 1.5	18	0.708
	20			20 - 1.5	20	0.787
	22	1/2	12	22 - 1.5	22	0.866
	24			24 - 1.5	24	0.944
	30	3/4	19	30 - 1.5	30	1.181
	33	1	25	33 - 1.5	33	1.299
36			36 - 1.5	36	1.417	
42			42 - 1.5	42	1.653	

Metric Japanese Industrial Standard - Metric - Female (Komatsu)

 <p>Applicable Standards Thread Form: Materials Available: Low Carbon Steel GB12361-12362 Part II (Drop Forged)</p>	Dash Size	Nominal Tube Size		Tread Size & Pitch	Thread ID 'D' on Diagram	
		in	mm		mm	in
	12			12 - 1.5	10.5	0.413
	14	1/4	6.4	14 - 1.5	12.5	0.492
	16			16 - 1.5	14.5	0.571
	18	3/8	10	18 - 1.5	16.5	0.649
	20			20 - 1.5	18.5	0.728
	22	1/2	12	22 - 1.5	20.5	0.807
	24			24 - 1.5	22.5	0.886
	30	3/4	19	30 - 1.5	28.5	1.122
	33	1	25	33 - 1.5	31.5	1.240
36			36 - 1.5	36.5	1.437	
42			42 - 1.5	40.5	1.594	

TECHNICAL DATA

Thread Identification

Japanese Industrial Standard - (BSPP) - Male

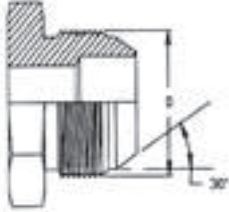
 <p>Applicable Standards Thread Form: JIS B8363 Materials Available: Low Carbon Steel GB12361-12362 Part II (Drop Forged)</p>	Dash Size	Nominal Tube Size		Thread Size & Pitch	Max Working Pressure		Thread OD 'D'on Diagram	
		in	mm		Bar	PSI	mm	in
	02	1/8	3.2	1/8 - 28	350	5,000	9.73	0.383
	04	1/4	6.4	1/4 - 19	350	5,000	13.16	0.518
	06	3/8	10	3/8 - 19	350	5,000	16.67	0.656
	08	1/2	12	1/2 - 14	350	5,000	20.96	0.825
	12	3/4	19	3/4 - 14	280	4,000	26.45	1.041
	16	1	25	1 - 11	210	3,000	33.25	1.309
	20	1 1/4	32	1 1/4 - 11	175	2,500	41.91	1.650
	24	1 1/2	38	1 1/2 - 11	105	1,500	47.81	1.882
32	2	50	2 - 11	105	1,500	59.62	2.347	

Japanese Industrial Standard - (BSPP) - Female

 <p>Applicable Standards Thread Form: JIS B8363 Materials Available: Low Carbon Steel GB12361-12362 Part II (Drop Forged)</p>	Dash Size	Nominal Tube Size		Thread Size & Pitch	Max Working Pressure		Thread OD 'D'on Diagram	
		in	mm		Bar	PSI	mm	in
	02	1/8	3.2	1/8 - 28	350	5,000	8.59	0.338
	04	1/4	6.4	1/4 - 19	350	5,000	11.46	0.451
	06	3/8	10	3/8 - 19	350	5,000	14.96	0.589
	08	1/2	12	1/2 - 14	350	5,000	18.65	0.734
	12	3/4	19	3/4 - 14	280	4,000	24.13	0.950
	16	1	25	1 - 11	210	3,000	30.30	1.193
	20	1 1/4	32	1 1/4 - 11	175	2,500	38.97	1.534
	24	1 1/2	38	1 1/2 - 11	105	1,500	44.86	1.766
32	2	50	2 - 11	105	1,500	56.67	2.231	

Thread Identification

Staple Lock - Male

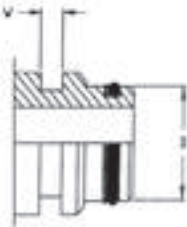
	Dash Size	Max Working Pressure DIN20 043		Nominal Tube Size		'W' on Diagram		'D' on Diagram	
		Bar	PSI	in	mm	mm	in	mm	in
	<p>Applicable Standards Thread Form: DIN 20 043 + SAE J1467 Materials Available: Low Carbon Steel GB12361-12362 Part II (Drop Forged)</p>	04	640	9,280	¼	6	5.1	0.201	9.90
	06	530	7,690	⅜	10	5.1	0.201	13.90	0.547
	08	500	7,250	½	13	5.1	0.201	17.90	0.705
	12	450	6,530	¾	20	5.1	0.201	23.90	0.941
	16	400	5,800	1	25	7.1	0.280	30.90	1.216
	20	300	4,350	1¼	32	7.1	0.280	37.90	1.492
	24	-	-	1½	40	7.1	0.280	46.90	1.846
	32	-	-	2	50	7.1	0.280	55.90	2.200

Staple Lock - Female

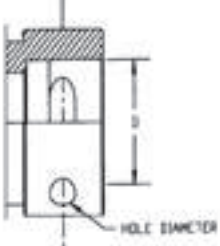
	Dash Size	Max Working Pressure DIN20 043		Nominal Tube Size		'W' on Diagram		'D' on Diagram	
		Bar	PSI	in	mm	mm	in	mm	in
	<p>Applicable Standards Thread Form: DIN 20 043 + SAE J1467 Materials Available: Low Carbon Steel GB12361-12362 Part II (Drop Forged)</p>	04	640	9,280	¼	6	6	0.235	15.16
	06	530	7,690	⅜	10	6	0.235	20.17	0.794
	08	500	7,250	½	13	6	0.235	24.16	0.951
	12	450	6,530	¾	20	6	0.235	29.16	1.148
	16	400	5,800	1	25	8.4	0.330	39.12	1.540
	20	300	4,350	1¼	32	8.4	0.330	46.15	1.817
	24	-	-	1½	40	8.75	0.345	55.22	2.174
	32	-	-	2	50	8.75	0.345	64.21	2.528

High Pressure Staple Lock - Male

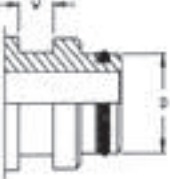
	Dash Size	Nominal Tube Size		'W' on Diagram		'D' on Diagram	
		in	mm	mm	in	mm	in
	<p>Applicable Standards Thread Form: Materials Available: Low Carbon Steel GB12361-12362 Part II (Drop Forged)</p>	12	¾	20	9	0.354	21.9
	16	1	25	13	0.511	27.0	1.062
	20	1¼	32	13	0.511	37.8	1.488
	24	1½	40	13	0.511	43.9	1.728
	32	2	50	13	0.511	49.9	1.964

TECHNICAL DATA

Thread Identification

High Pressure Staple Lock - Female

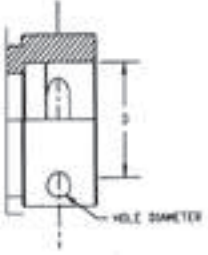
 <p>Applicable Standards Thread Form: Materials Available: Low Carbon Steel GB12361-12362 Part II (Drop Forged)</p>	Dash Size	Nominal Tube Size		'W' on Diagram		'D' on Diagram	
		in	mm	mm	in	mm	in
	12	¾	20	9.5	0.374	30.2	1.189
	16	1	25	13.5	0.531	40.4	1.590
	20	1¼	32	13.5	0.531	46.6	1.834
	24	1½	40	13.5	0.531	56.6	2.230
32	2	50	13.5	0.531	65.4	2.574	

Code 61 Flange - SAE J518

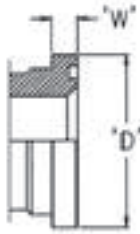
 <p>Applicable Standards Thread Form: SAE J518 Materials Available: Low Carbon Steel GB12361-12362 Part II (Drop Forged)</p>	Dash Size	Nominal Tube Size		'W' on Diagram		Max Working Pressure		Flange O.D. 'D' on Diagram	
		in	mm	mm	in	Bar	PSI	mm	in
	08	½	12.7	6.73	0.265	350	5,000	30.18	1.188
	10	⅝	16	6.73	0.265	350	5,000	34.00	1.340
	12	¾	19	6.73	0.265	350	5,000	38.10	1.500
	16	1	25.4	8.00	0.315	350	5,000	44.45	1.750
	20	1¼	32	8.00	0.315	280	4,000	50.80	2.000
	24	1½	38	8.00	0.315	280	4,000	60.33	2.375
	32	2	51	9.53	0.375	210	3,000	71.42	2.812
	40	2½	63.5	9.53	0.375	190	2,750	84.12	3.312
	48	3	76	9.53	0.375	138	2,000	101.6	4
	56	3½	89	11.23	0.442	35	500	114.3	4.5
	64	4	102	11.23	0.442	35	500	127.0	5
80	5	127	11.23	0.442	35	500	152.4	6	

Code 62 Flange - SAE J518

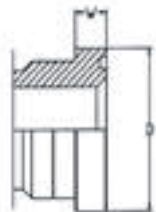
 <p>Applicable Standards Thread Form: SAE J518 Materials Available: Low Carbon Steel GB12361-12362 Part II (Drop Forged)</p>	Dash Size	Nominal Tube Size		'W' on Diagram		Max Working Pressure		Flange O.D. 'D' on Diagram	
		in	mm	mm	in	Bar	PSI	mm	in
	08	½	12.7	7.75	0.305	420	6,000	31.75	1.250
	12	¾	19	8.76	0.345	420	6,000	41.28	1.625
	16	1	25.4	9.53	0.375	420	6,000	47.63	1.875
	20	1¼	32	10.29	0.405	420	6,000	53.98	2.125
	24	1½	38	12.57	0.495	420	6,000	63.50	2.500
32	2	51	12.57	0.495	420	6,000	79.38	3.125	

Thread Identification

Caterpillar® Type Flange

Dash Size	Nominal Tube Size		'W' on Diagram		Max Working Pressure		Flange O.D. 'D' on Diagram	
	in	mm	mm	in	Bar	PSI	mm	in
12	¾	19	14.2	0.560	420	6,000	41.28	1.625
16	1	25.4	14.2	0.560	420	6,000	47.63	1.875
20	1¼	32	14.2	0.560	420	6,000	53.98	2.125
24	1½	38	14.2	0.560	420	6,000	63.50	2.500
32	2	51	14.2	0.560	420	6,000	79.38	3.125

Applicable Standards

Thread Form: SAE J518

Materials Available: Low Carbon Steel
GB12361-12362 Part II (Drop Forged)

Code 61 Split Flange

Flange Size	A	B	C	D	E	F	G	H	J	*Torque Range (Ft-Lb)
08	.86	2.12	1.500	.75	.50	1.219	.955	.245	.344	15-19
12	.98	2.56	1.875	.88	.56	1.531	1.265	.245	.406	21-29
16	1.11	2.75	2.062	.94	.62	1.781	1.515	.295	.406	27-35
20	1.39	3.12	2.312	.88	.56	2.031	1.720	.295	.469	35-42
24	1.58	3.69	2.750	1.00	.62	2.406	2.000	.295	.531	46-58
32	1.86	4.00	3.062	1.03	.62	2.844	2.470	.355	.531	54-67
40	2.09	4.50	3.500	1.50	.75	3.344	2.950	.355	.531	79-92
48	2.53	5.31	4.188	1.62	.88	4.031	3.580	.355	.656	138-150
56	2.70	6.00	4.750	1.12	.88	4.531	4.030	.422	.656	117-133
64	2.95	6.38	5.125	1.38	1.00	5.031	4.530	.422	.656	117-133

*Torque range applies to grade 5 bolts.

Code 62 Split Flange

Flange Size	A	B	C	D	E	F	G	H	J	*Torque Range (Ft-Lb)
08	.89	2.22	1.594	.88	.62	1.281	.970	.285	.344	15-19
12	1.14	2.81	2.000	1.12	.75	1.656	1.280	.325	.406	25-33
16	1.33	3.19	2.250	1.31	.94	1.906	1.530	.355	.489	42-50
20	1.48	3.75	2.625	1.50	1.06	2.156	1.750	.385	.531	63-75
24	1.83	4.44	3.125	1.69	1.19	2.531	2.030	.475	.656	117-133
32	2.20	5.25	3.812	2.06	1.44	3.156	2.660	.475	.781	200-217

*Torque range applies to grade 8 bolts.

TECHNICAL DATA

Thread Identification

Caterpillar® Split Flange

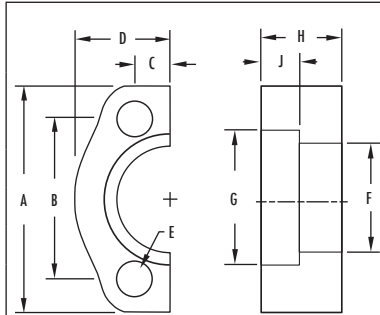

Flange Size	A	B	C	D	E	F	G	H	J	*Torque Range (Ft-Lb)
12	2.95	2.000	.446	1.210	.406	1.270	1.632	1.102	.530	25-33
16	3.19	2.250	.507	1.335	.469	1.550	1.884	1.102	.530	42-50
20	3.75	2.625	.585	1.490	.531	1.705	2.134	1.102	.530	63-75
24	4.44	3.125	.679	1.335	.656	2.080	2.509	1.258	.530	117-133
32	5.240	3.812	.834	2.205	.827	2.640	3.130	1.457	.530	200-217

Applicable Standards
 Materials Available: Low Carbon Steel
 GB12361-12362
 Part II (Drop Forged)

*Torque range applies to grade 8 bolts.

'O' Ring Face Seal - Male

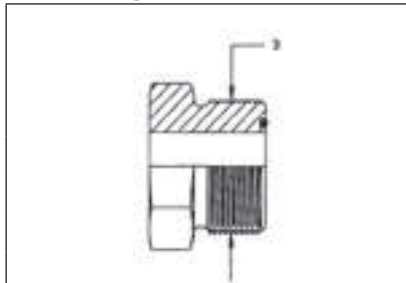

Applicable Standards
 Thread Form: SAE J1453
 Materials Available: Low Carbon Steel
 GB12361-12362 Part II
 (Drop Forged)

Dash Size	Nominal Tube Size		Nominal Thread Size & Pitch	Correct Torque (Ft-Lb)	Max Working Pressure SAE J1453		Thread OD 'D' on Diagram	
	in	mm			Bar	PSI	mm	in
04	1/4	6.4	9/16 - 18	11	635	9,200	14.22	0.56
06	3/8	10	11/16 - 16	18	635	9,200	17.52	0.69
08	1/2	12	13/16 - 16	33	635	9,200	20.82	0.82
10	5/8	16	1 - 14	48	420	6,000	25.4	1.00
12	3/4	19	13/16 - 12	70	420	6,000	30.22	1.19
16	1	25	17/16 - 12	96	420	6,000	36.57	1.44
20	1 1/4	32	1 11/16 - 12	140	280	4,000	42.92	1.69
24	1 1/2	38	2 - 12	162	280	4,000	50.80	2.00

'O' Ring Face Seal - Female

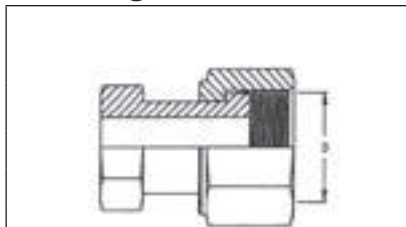

Applicable Standards
 Thread Form: SAE J1453
 Materials Available: Low Carbon Steel
 GB12361-12362 Part II
 (Drop Forged)

Dash Size	Nominal Tube Size		Nominal Thread Size & Pitch	Correct Torque (Ft-Lb)	Max Working Pressure SAE J1453		Thread OD 'D' on Diagram	
	in	mm			Bar	PSI	mm	in
04	1/4	6.4	9/16 - 18	11	635	9,200	12.95	0.51
06	3/8	10	11/16 - 16	18	635	9,200	16.00	0.63
08	1/2	12	13/16 - 16	33	635	9,200	19.05	0.75
10	5/8	16	1 - 14	48	420	6,000	23.62	0.93
12	3/4	19	13/16 - 12	70	420	6,000	28.19	1.11
16	1	25	17/16 - 12	96	420	6,000	34.54	1.36
20	1 1/4	32	1 11/16 - 12	140	280	4,000	40.89	1.61
24	1 1/2	38	2 - 12	162	280	4,000	48.76	1.92

Thread Identification

GAZ French Metric - Male

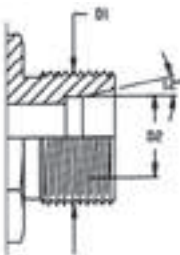
 Applicable Standards Thread Form: Materials Available: Low Carbon Steel	Dash Size	Nominal Tube Size 'D2'	Nominal Thread Size and Pitch	Thread O.D. 'D' on Diagram	
		mm		mm	in
		20	13.25	M20 - 1.5	20
	24	16.75	M24 - 1.5	24	0.944
	30	21.25	M30 - 1.5	30	1.181
	36	26.75	M36 - 1.5	36	1.417
	45	33.50	M45 - 1.5	45	1.771
	52	42.25	M52 - 1.5	52	2.047
	58	48.25	M58 - 2.0	58	2.283

GAZ French Metric - Female

 Applicable Standards Thread Form: Materials Available: Low Carbon Steel	Dash Size	Nominal Tube Size 'D2'	Nominal Thread Size and Pitch	Thread O.D. 'D' on Diagram	
		mm		mm	in
		20	13.25	M20 - 1.5	18.5
	24	16.75	M24 - 1.5	22.5	0.885
	30	21.25	M30 - 1.5	28.5	1.122
	36	26.75	M36 - 1.5	34.5	1.358
	45	33.50	M45 - 1.5	43.5	1.712
	52	42.25	M52 - 1.5	50.5	1.988
	58	48.25	M58 - 2.0	55.0	2.165

TECHNICAL DATA

Thread Identification

Kobelco Metric - Male

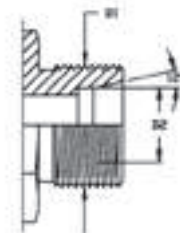

Applicable Standards
Thread Form:
Materials Available: Low Carbon Steel

Dash Size	Nominal Tube Size 'D2'	Nominal Thread Size and Pitch	Thread O.D. 'D' on Diagram	
	mm		mm	in
30	22.30	M30 - 1.5	30	1.181
36	28.20	M36 - 1.5	36	1.417
45	35.20	M45 - 1.5	45	1.771

Kobelco Metric - Female



Applicable Standards
Thread Form:
Materials Available: Low Carbon Steel

Dash Size	Nominal Tube Size 'D2'	Nominal Thread Size and Pitch	Thread O.D. 'D' on Diagram	
	mm		mm	in
30	22.30	M30 - 1.5	28.5	1.122
36	28.20	M36 - 1.5	34.5	1.358
45	35.20	M45 - 1.5	43.5	1.712



TECHNICAL DATA

TECHNICAL DATA

HOSE



FLEXTURAL

NT300-



HOSE

J3 Rubber Cover Push-On 300 PSI

Tube: High oil resistant synthetic rubber
Reinforcement: Synthetic Fiber
Cover: Black, oil, abrasion and weather resistant synthetic rubber, MSHA approved
Temperature: -40°C to +88°C (-40°F to + 190°F)
Packaging: Reels
Application: Petroleum based hydraulic fluids, gasoline, water, diesel fuels and lubricating oils



PART NUMBER	HOSE I.D.		HOSE O.D.		MAXIMUM WORKING PRESSURE (psi)	MINIMUM BURST PRESSURE (psi)	MINIMUM BEND RADIUS		WEIGHT (lbs/ft)	ONE PIECE COUPLINGS
	(in)	(mm)	(in)	(mm)			(in)	(mm)		
J3-04BK*	1/4	6.35	0.54	13.7	300	1,200	3.0	64	0.09	J
J3-05BK*	5/16	7.94	0.62	15.7	300	1,200	3.0	76	0.12	J
J3-06BK*	3/8	9.53	0.69	17.5	300	1,200	3.0	76	0.14	J
J3-08BK*	1/2	12.7	0.81	20.6	300	1,200	5.0	127	0.17	J
J3-10BK*	5/8	15.88	0.93	23.6	300	1,200	6.0	152	0.20	J
J3-12BK*	3/4	19.05	1.07	27.2	300	1,200	7.0	178	0.26	J
J3-16BK*	1	25.4	1.34	34.0	300	1,200	8.0	203	0.34	J

* BK indicates the color black, for other colors change the suffix to the following: BL - Blue, GY - Grey, GN - Green, RD - Red, BN - Brown, YW - Yellow or WH - White. Some colors are non-stock and may require minimum runs.

J4 Rubber Cover Push-On Premium High Temp

Tube: Oil resistant synthetic rubber
Reinforcement: One synthetic textile braid
Cover: Black, oil resistant rubber
Temperature: -40°C to +150°C (-40°F to + 300°F) petroleum-based fluids
 -40°C to +85°C (-40°F to + 185°F) water and air
Packaging: Reels
Application: For lubricating and fuel oils, air and water.



PART NUMBER	HOSE I.D.		HOSE O.D.		MAXIMUM WORKING PRESSURE (psi)	MINIMUM BURST PRESSURE (psi)	MINIMUM BEND RADIUS		WEIGHT (lbs/ft)	ONE PIECE COUPLINGS
	(in)	(mm)	(in)	(mm)			(in)	(mm)		
J4-04BK	1/4	6.35	0.51	12.8	350	1,400	2.5	64	0.09	J
J4-06BK	3/8	9.53	0.67	17.0	350	1,400	3.0	76	0.14	J
J4-08BK	1/2	12.7	0.76	19.3	300	1,200	5.0	127	0.16	J
J4-10BK	5/8	15.88	0.93	23.6	300	1,200	6.0	152	0.20	J
J4-12BK	3/4	19.05	1.05	26.5	300	1,200	7.0	175	0.25	J

YK Rubber DOT Air Brake Hose

Tube: Black Nitrile
Reinforcement: Synthetic Fiber
Cover: Black, oil, abrasion and weather resistant synthetic rubber
Temperature: -29°C to +88°C (-20°F to +190°F)
Packaging: Reels
Application: Air brake hose lines



PART NUMBER	HOSE I.D.		HOSE O.D.		MAXIMUM WORKING PRESSURE (psi)	MINIMUM BURST PRESSURE (psi)	MINIMUM BEND RADIUS		WEIGHT (lbs/ft)	REUSABLE COUPLINGS
	(in)	(mm)	(in)	(mm)			(in)	(mm)		
YK-06	3/8	9.53	0.75	19.05	225	900	2.25	57.15	0.17	Y
YK-08	1/2	12.7	0.88	22.23	225	900	3.00	76.20	0.20	Y

HJ Hydraulic Jack Hose

Meets Material Handling Institute Specification IJ 100 for hydraulic hose and assemblies used with jacking systems.



- Tube: Seamless, black, oil and heat resistant synthetic rubber
 - Reinforcement: Two braids of high tensile steel wire
 - Cover: Black, oil, abrasion and weather resistant synthetic rubber
 - Temperature: -40°C to +100°C (-40°F to +212°F)
 - Packaging: Reels
 - Application: Extreme high pressure hydraulic lines for jacking systems
- Due to high pressure application, we recommend solid NPT ends.**

PART NUMBER	HOSE I.D.		HOSE O.D.		MAXIMUM WORKING PRESSURE (psi)	MINIMUM BURST PRESSURE (psi)		MINIMUM BEND RADIUS		WEIGHT (lbs/ft)	ONE PIECE COUPLINGS
	(in)	(mm)	(in)	(mm)		(in)	(mm)	(in)	(mm)		
HJ-04	1/4	6.35	0.59	15.0	10,000	20,000	4.0	100	0.20	E	
HJ-06	3/8	9.52	0.75	19.0	10,000	20,000	5.0	130	0.29	E	

ZX Air Conditioning (Standard Barrier)

Meets or exceeds J2064 "Type C Class II" Hose Performance



- Tube: Chloroprene
- Reinforcement: Two-spiral polyester
- Barrier: Nylon
- Cover: Black EPDM
- Temperature: -40°C to +135°C (-40°F to +275°F)
- Packaging: Reels
- Application: R12 / R134a refrigerants

PART NUMBER	HOSE I.D.		HOSE O.D.		MAXIMUM WORKING PRESSURE (psi)	MINIMUM BURST PRESSURE (psi)		MINIMUM BEND RADIUS		WEIGHT (lbs/ft)	ONE PIECE COUPLINGS
	(in)	(mm)	(in)	(mm)		(in)	(mm)	(in)	(mm)		
ZX-06	5/16	7.92	0.75	19.1	500	2,000	0.6	16	0.20	Z	
ZX-08	13/32	10.16	0.91	23.0	500	2,000	1.0	25	0.28	Z	
ZX-10	1/2	12.70	1.00	25.4	500	2,000	1.3	32	0.33	Z	
ZX-12	5/8	15.88	1.13	28.6	350	1,750	2.0	50	0.38	Z	

ZXR Air Conditioning (Reduced Barrier)

Meets or exceeds J2064 "Type C Class II" Hose Performance



- Tube: Chloroprene
- Reinforcement: Single-braid polyester
- Barrier: Nylon
- Cover: Black Chlorobutyl
- Temperature: -40°C to +135°C (-40°F to +275°F)
- Packaging: Reels
- Application: R12 / R134a refrigerants

PART NUMBER	HOSE I.D.		HOSE O.D.		MAXIMUM WORKING PRESSURE (psi)	MINIMUM BURST PRESSURE (psi)		MINIMUM BEND RADIUS		WEIGHT (lbs/ft)	ONE PIECE COUPLINGS
	(in)	(mm)	(in)	(mm)		(in)	(mm)	(in)	(mm)		
ZXR-06	5/16	7.92	0.56	14.7	500	2,000	1.0	25	0.09	ZR	
ZXR-08	13/32	10.16	0.69	17.3	500	2,000	1.5	38	0.12	ZR	
ZXR-10	1/2	12.70	0.75	19.4	500	2,000	2.5	63	0.13	ZR	
ZXR-12	5/8	15.88	0.94	23.6	350	1,750	4.0	104	0.20	ZR	

HOSE

TBR Smooth Bore Teflon / Stainless Steel Wire

Meets or exceeds the requirements of SAE 100R14



- Tube: Smooth bore teflon (.030 wall)
- Cover: One braid of 304 stainless steel wire
- Temperature: -54°C to 232°C (-65°F to +450°F) Continuous service
-73°C to +260°C (-100°F to +500°F) Intermittent service
- Packaging: Random coils
- Application: Steam, chemical, automotive, food processing, pharmaceutical and petroleum based hydraulic fluids

PART NUMBER	HOSE I.D.		HOSE O.D.		MAXIMUM WORKING PRESSURE (psi)	MINIMUM BURST PRESSURE (psi)		MINIMUM BEND RADIUS		WEIGHT (lbs/ft)	ONE PIECE COUPLINGS
	(in)	(mm)	(in)	(mm)		(in)	(mm)				
TBR-03	3/16	0.30	7.6	2,750	11,000	2.0	50	0.07	T, TS		
TBR-04	1/4	0.35	8.8	2,610	10,440	3.0	75	0.10	T, TS		
TBR-05	5/16	0.43	11.0	2,540	10,160	4.0	100	0.11	T, TS		
TBR-06	3/8	0.48	12.1	2,390	9,560	5.0	125	0.12	T, TS		
TBR-08	1/2	0.64	16.2	1,740	6,960	6.6	165	0.15	T, TS		
TBR-10	5/8	0.74	18.8	1,270	5,080	8.0	200	0.17	T, TS		
TBR-12	3/4	0.91	23.1	1,010	4,040	9.2	230	0.20	T, TS		
TBR-16	1	1.15	29.2	870	3,480	12	300	0.30	T, TS		

Note: TBR-03 thru -08 sizes are rated for full vacuum.

TBX Convoluted Smooth Bore Teflon Stainless



- Tube: Black non-leaching FDA compliant static conductive
- Cover: One braid of 304 stainless steel wire
- Temperature: -54°C to 232°C (-65°F to +450°F) Continuous service
-73°C to +260°C (-100°F to +500°F) Intermittent service
- Packaging: Random coils
- Application: Steam, chemical, automotive, food processing, pharmaceutical and petroleum based hydraulic fluids

PART NUMBER	HOSE I.D.		HOSE O.D.		MAXIMUM WORKING PRESSURE (psi)	MINIMUM BEND RADIUS		WEIGHT (lbs/ft)	ONE PIECE Skive COUPLINGS
	(in)	(mm)	(in)	(mm)		(in)	(mm)		
TBX-04C	1/4	0.38	9.6	1280	0.8	19	0.06	T, TS	
TBX-05C	5/16	0.42	10.6	1220	0.8	19	0.08	T, TS	
TBX-06C	3/8	0.53	13.5	1160	1.0	25	0.10	T, TS	
TBX-08C	1/2	0.69	17.5	870	1.5	38	0.15	T, TS	
TBX-10C	5/8	0.83	21.1	730	2.0	50	0.23	T, TS	
TBX-12C	3/4	0.95	24.2	610	2.5	63	0.26	T, TS	
TBX-16C	1	1.25	31.7	580	3.0	75	0.36	T, TS	

Note: Also available with Natural non-conductive PTFE Tube (Remove "C" at end of part number, ie TBX-04).

FSH 100R1 Red Fire Suppression Hose

Meets or exceeds the requirements of SAE 100R1 AT / DIN-EN 853 1SN



- Tube: Seamless, black, oil and heat resistant synthetic rubber
- Reinforcement: One wire braid of high tensile steel wire
- Cover: Red, oil abrasion and weather resistant synthetic rubber, MSHA approved
- Temperature: -40°C to +100°C (-40°F to +212°F)
- Packaging: Reels
- Application: Medium pressure hydraulic applications and fire suppression actuation equipment where the red cover allows for easy identification.

PART NUMBER	HOSE I.D.		HOSE O.D.		MAXIMUM WORKING PRESSURE (psi)	MINIMUM BURST PRESSURE (psi)	MINIMUM BEND RADIUS		WEIGHT (lbs/ft)	ONE PIECE COUPLINGS
	(in)	(in)	(mm)	(in)			(mm)			
FSH-04	¼	0.52	13.2		3,265	13,060	4.0	100	0.15	E
FSH-06	⅜	0.68	17.2		2,610	10,440	5.0	130	0.23	E
FSH-08	½	0.80	20.4		2,320	9,280	7.0	180	0.28	E
FSH-12	¾	1.08	27.5		1,525	6,100	9.5	240	0.40	E
FSH-16	1	1.39	35.4		1,275	5,100	12.0	300	0.59	E

LX 100R3 Rubber Cover Fabric Braid

Meets or exceeds the requirements of SAE 100R3



- Tube: Black, oil and heat-resistant synthetic rubber
- Reinforcement: Two braids of synthetic yarn
- Cover: Black, oil abrasion and weather resistant synthetic rubber
- Temperature: -40°C to +100°C (-40°F to +212°F)
- Packaging: Reels
- Application: Petroleum based hydraulic fluids and pneumatic service

PART NUMBER	HOSE I.D.		HOSE O.D.		MAXIMUM WORKING PRESSURE (psi)	MINIMUM BURST PRESSURE (psi)	MINIMUM BEND RADIUS		WEIGHT (lbs/ft)	ONE PIECE COUPLINGS
	(in)	(in)	(mm)	(in)			(mm)			
LX-04	¼	0.56	14.3		1,250	5,000	3.0	76	0.12	E
LX-06	⅜	0.75	19.0		1,125	4,500	4.0	102	0.17	E, N
LX-08	½	0.94	23.8		1,000	4,000	5.0	127	0.25	E, N

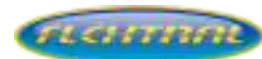

HOSE

PROJET® 3000 3000 PSI Pressure Wash

Tube: Seamless, black synthetic rubber
Reinforcement: One braid of high tensile steel wire
Cover: Smooth abrasion & weather resistant synthetic rubber, Blue
Temperature: -40°C to +121°C/149°C Intermittent (-40°F to +250°F/300° Intermittent)
Packaging: 50' 100' 150' 200' Bulk Reels
Application: Pressure wash equipment



PART NUMBER	COVER	HOSE O.D.			MAXIMUM WORKING PRESSURE (psi)	MINIMUM BEND RADIUS		WEIGHT (lbs/ft)	ONE PIECE COUPLINGS
		HOSE I.D. (in)	(in)	(mm)		(in)	(mm)		
PJ3-08BLM	Smooth	1/2	0.75	19.0	3,000	5.5	140	0.32	E

*Not For Steam Service

PROJET® 4000 4000 PSI Pressure Wash

Tube: Seamless, black synthetic rubber
Reinforcement: One braid of high tensile steel wire
Cover: Wrapped abrasion & weather resistant synthetic rubber, Black, Blue or Gray
Temperature: -40°C to +121°C/149°C Intermittent (-40°F to +250°F/300° Intermittent)
Packaging: 50' 100' 150' 200' Bulk Reels
Application: Pressure wash equipment



PART NUMBER	COVER	HOSE O.D.			MAXIMUM WORKING PRESSURE (psi)	MINIMUM BEND RADIUS		WEIGHT (lbs/ft)	ONE PIECE COUPLINGS
		HOSE I.D. (in)	(in)	(mm)		(in)	(mm)		
PJ4-06BK	Wrapped	3/8	0.61	15.5	4,000	3.5	90	0.17	E
PJ4-06BL	Wrapped	3/8	0.61	15.5	4,000	3.5	90	0.17	E
PJ4-06GY	Wrapped	3/8	0.61	15.5	4,000	3.5	90	0.17	E

*Not For Steam Service

PROJET® 4000 4000 PSI Pressure Wash

Tube: Seamless, black synthetic rubber
Reinforcement: One braid of high tensile steel wire
Cover: Smooth abrasion & weather resistant synthetic rubber, Blue
Temperature: -40°C to +121°C/149°C Intermittent (-40°F to +250°F/300° Intermittent)
Packaging: 50' 100' 150' 200' Bulk Reels
Application: Pressure wash equipment



PART NUMBER	COVER	HOSE O.D.			MAXIMUM WORKING PRESSURE (psi)	MINIMUM BEND RADIUS		WEIGHT (lbs/ft)	ONE PIECE COUPLINGS
		HOSE I.D. (in)	(in)	(mm)		(in)	(mm)		
PJ4-04BLM	Smooth	1/4	0.48	12.2	4,000	2.9	75	0.19	E
PJ4-06BLM	Smooth	3/8	0.61	15.5	4,000	3.5	90	0.24	E

*Not For Steam Service



HOSE

ULTRAJET® 4000 Oil Resistant Pressure Wash

- Tube: Seamless, black synthetic rubber
- Reinforcement: One braid of high tensile steel wire
- Cover: Yellow smooth ultra abrasion resistant synthetic rubber, RMA Class A
- Temperature: -40°C to +121°C (-40°F to +250°F)
- Packaging: 50' 100' 150' 200' Bulk Reels
- Application: Pressure Wash equipment where maximum abrasion or oil/fat resistance is required



PART NUMBER	COVER	HOSE I.D.		HOSE O.D.		MAXIMUM WORKING PRESSURE	MINIMUM BEND RADIUS		WEIGHT	ONE PIECE COUPLINGS
		(in)	(mm)	(in)	(mm)		(in)	(mm)		
UJ4-06YWM	Smooth	3/8	15.5	0.61	15.5	4,000	3.5	90	0.24	E

*Not For Steam Service

SUPERJET® 6000 6000 PSI Pressure Wash

- Tube: Seamless, black synthetic rubber
- Reinforcement: Two braids of high tensile steel wire
- Cover: Wrapped abrasion & weather resistant synthetic rubber, Black, Blue or Gray
- Temperature: -40°C to +121°C/149°C Intermittent (-40°F to +250°F/300° Intermittent)
- Packaging: 50' 100' 150' 200' Bulk Reels
- Application: Pressure wash equipment



PART NUMBER	COVER	HOSE I.D.		HOSE O.D.		MAXIMUM WORKING PRESSURE	MINIMUM BEND RADIUS		WEIGHT	ONE PIECE COUPLINGS
		(in)	(mm)	(in)	(mm)		(in)	(mm)		
SJ6-06BK	Wrapped	3/8	17.1	0.673	17.1	6,000	3.5	90	0.29	E
SJ6-06BL	Wrapped	3/8	17.1	0.673	17.1	6,000	3.5	90	0.29	E
SJ6-06GY	Wrapped	3/8	17.1	0.673	17.1	6,000	3.5	90	0.29	E

*Not For Steam Service

SUPERJET® 6000 6000 PSI Pressure Wash

- Tube: Seamless, black synthetic rubber
- Reinforcement: Two braids of high tensile steel wire
- Cover: Smooth abrasion & weather resistant synthetic rubber, Blue
- Temperature: -40°C to +121°C/149°C Intermittent (-40°F to +250°F/300° Intermittent)
- Packaging: 50' 100' 150' 200' Bulk Reels
- Application: Pressure wash equipment



PART NUMBER	COVER	HOSE I.D.		HOSE O.D.		MAXIMUM WORKING PRESSURE	MINIMUM BEND RADIUS		WEIGHT	ONE PIECE COUPLINGS
		(in)	(mm)	(in)	(mm)		(in)	(mm)		
SJ6-06BLM	Smooth	3/8	17.1	0.673	17.1	6,000	3.5	90	0.29	E
SJ6-08BLM	Smooth	1/2	20.7	0.81	20.7	6,000	5.1	130	0.39	E

*Not For Steam Service



HOSE

607 100R7 Thermoplastic

Meets or exceeds the requirements of SAE 100R7 / JIS K6375 / ISO 3949



- Tube: Nylon
- Reinforcement: Synthetic Fiber
- Cover: Black perforated high abrasion resistant polyurethane
- Temperature: -40°C to +100°C (-40°F to +212°F)
- Packaging: Coils
- Application: Hydraulic and pneumatics, chemical transfer, forklift, lubrication, high pressure gas transfer, fire resistant fluids, material handling, robotics

PART NUMBER	HOSE I.D.		HOSE O.D.		MAXIMUM WORKING PRESSURE (psi)	MINIMUM BURST PRESSURE (psi)	MINIMUM BEND RADIUS		WEIGHT (lbs/ft)	ONE PIECE COUPLINGS
	(in)	(mm)	(in)	(mm)			(in)	(mm)		
607-02	1/8	3.18	0.33	8.3	3000	12000	0.59	15	0.030	Contact Flextral
607-03	3/16	4.75	0.41	10.4	3000	12000	0.79	20	0.043	P, T
607-04	1/4	6.35	0.50	12.7	3000	12000	1.57	40	0.070	P, T
607-05	5/16	7.92	0.58	14.7	2500	10000	1.77	45	0.087	P, T
607-06	3/8	9.53	0.66	16.4	2250	9000	1.96	50	0.101	P, T
607-08	1/2	12.7	0.80	20.3	2000	8000	2.95	75	0.141	P, T
607-12	3/4	19.05	1.05	26.6	1250	5000	5.12	130	0.195	P, T
607-16	1	25.4	1.31	33.4	1000	4000	6.50	165	0.268	P, T

Note: P couplings may be swaged or crimped. T couplings are crimp only.

707N 100R7 Non-conductive Thermoplastic

Meets or exceeds the requirements of SAE 100R7 / ANSI 92.2 standard for aerial lift equipment. SAEJ517 less than 50 Microamps leakage at 75,000v for 5 min.



- Tube: Polyester
- Reinforcement: Synthetic fiber
- Cover: Orange low friction high abrasion and UV resistant urethane, non-perforated
- Temperature: -40°C to +100°C (-40°F to +212°F)
- Packaging: Reels
- Application: Hydraulics requiring electrical isolation, utility, rescue tools, aerial equipment

PART NUMBER	HOSE I.D.		HOSE O.D.		ANSI A92.2 MAXIMUM WORKING PRESSURE (psi)	MINIMUM BURST PRESSURE (psi)	MINIMUM BEND RADIUS		WEIGHT (lbs/ft)	ONE PIECE COUPLINGS
	(in)	(mm)	(in)	(mm)			(in)	(mm)		
707N-03	3/16	4.75	0.43	10.9	3,250	12,000	0.75	19	0.05	P, T
707N-04	1/4	6.35	0.51	12.9	3,150	11,000	1.26	32	0.05	P, T
707N-05	5/16	7.92	0.59	15.0	3,150	10,000	1.75	44	0.08	P, T
707N-06	3/8	9.53	0.66	16.9	3,000	9,000	2.00	51	0.10	P, T
707N-08	1/2	12.7	0.81	20.7	3,000	9,000	3.00	76	0.15	P, T

Note: P couplings may be swaged or crimped. T couplings are crimp only.



HOSE

617 Wire Braided Thermoplastic Hose

Meets or exceeds the requirements of SAE 100R1-EN8531ST



- Tube:** Polyester
- Reinforcement:** 1 or 2 High tensile steel braid
- Cover:** Black marine grade high abrasion urethane.
Low friction matte finish - non-perforated
- Temperature:** -40°C to +100°C (-40°F to +212°F)
- Packaging:** Coils
- Application:** General hydraulics, lubrication, fork-lift

PART NUMBER	HOSE I.D.		HOSE O.D.		MAXIMUM WORKING PRESSURE (psi)	MINIMUM BURST PRESSURE (psi)	MINIMUM BEND RADIUS		WEIGHT (lbs/ft)	ONE PIECE COUPLINGS
	(in)	(mm)	(in)	(mm)			(in)	(mm)		
617-04	1/4	6.35	0.47	12	4300	17200	1.60	40	0.114	P
617-06	3/8	9.52	0.63	16	3200	12800	2.25	57	0.175	P
617-08	1/2	12.7	0.76	19.2	2700	10800	1.95	75	0.219	P
617-12	3/4	19.05	1.04	26.5	1800	7200	5.90	150	0.305	P

Note: Multiline available upon special order.

HOSE

618 100R18 Low-Temp Thermoplastic

Meets or exceeds the requirements of SAE 100R18



- Tube:** Polyester
- Reinforcement:** Synthetic Fiber
- Cover:** Black low friction high abrasion and UV resistant urethane, micro-perforated
- Temperature:** -50°C to +100°C (-58°F to +212°F)
For use with water and water-based hydraulic fluids to +70°C (+158°F)
- Packaging:** Coils
- Application:** Forklift, construction, general hydraulics, chem/gas, lubrication, hydraulic tools, machine tools

PART NUMBER	HOSE I.D.		HOSE O.D.		MAXIMUM WORKING PRESSURE (psi)	MINIMUM BURST PRESSURE (psi)	MINIMUM BEND RADIUS		WEIGHT (lbs/ft)	ONE PIECE COUPLINGS
	(in)	(mm)	(in)	(mm)			(in)	(mm)		
618-02	1/8	3.18	0.34	8.5	3,000	12,000	0.98	25	0.04	P
618-03	3/16	4.78	0.41	10.5	3,500	14,000	1.18	30	0.06	P
618-04	1/4	6.35	0.50	12.7	3,500	14,000	1.38	35	0.07	P
618-05	5/16	7.94	0.59	15.0	3,500	14,000	1.97	50	0.10	P
618-06	3/8	9.53	0.65	16.5	3,500	14,000	2.95	75	0.10	P
618-08	1/2	12.70	0.85	21.6	3,000	12,000	3.54	90	0.17	P

618W 100R18 Low-Temp Twinline Thermoplastic

Meets or exceeds the requirements of SAE 100R18



- Tube:** Polyester
- Reinforcement:** Synthetic Fiber
- Cover:** Black low friction high abrasion and UV resistant urethane, micro-perforated
- Temperature:** -50°C to +100°C (-58°F to +212°F)
For use with water and water-based hydraulic fluids to +70°C (+158°F)
- Packaging:** Coils
- Application:** Forklift, construction, general hydraulics, chem/gas, lubrication, hydraulic tools, machine tools

PART NUMBER	HOSE I.D.		HOSE O.D.		MAXIMUM WORKING PRESSURE (psi)	MINIMUM BURST PRESSURE (psi)	MINIMUM BEND RADIUS		WEIGHT (lbs/ft)	ONE PIECE COUPLINGS
	(in)	(mm)	(in)	(mm)			(in)	(mm)		
618W-0202	1/8	3.18	0.34	8.5	3,000	12,000	0.98	25	0.08	P
618W-0303	3/16	4.78	0.41	10.5	3,500	14,000	1.18	30	0.10	P
618W-0404	1/4	6.35	0.50	12.7	3,500	14,000	1.38	35	0.14	P
618W-0505	5/16	7.94	0.59	15.0	3,500	14,000	1.97	50	0.20	P
618W-0606	3/8	9.53	0.65	16.5	3,500	14,000	2.95	75	0.20	P
618W-0808	1/2	12.70	0.85	21.6	3,000	12,000	3.54	90	0.34	P

618N 100R18 Non-Conductive Low-Temp Thermoplastic Pressure Hose 3000-3500psi

Meets or exceeds SAE100R18 / ANSI 92.2 standard
For aerial lift equipment, SAEJ517 less than 50 Microamps leakage at 75,000v for 5 minutes.



- Tube:** Polyester
- Reinforcement:** Synthetic Fiber
- Cover:** Orange low friction high abrasion and UV resistant urethane, non-perforated
- Temperature:** -50°C to +100°C (-58°F to +212°F)
For use with water and water-based hydraulic fluids to +70°C (+158°F)
- Packaging:** Coils
- Application:** Hydraulics requiring electrical isolation, utility, rescue tools, aerial equipment

PART NUMBER	HOSE I.D.		HOSE O.D.		MAXIMUM WORKING PRESSURE (psi)	MINIMUM BURST PRESSURE (psi)	MINIMUM BEND RADIUS		WEIGHT (lbs/ft)	ONE PIECE COUPLINGS
	(in)	(mm)	(in)	(mm)			(in)	(mm)		
618N-02	1/8	0.34	8.5	3,000	14,000	0.98	25	0.04	P	
618N-03	3/16	0.41	10.5	3,500	14,000	1.18	30	0.05	P	
618N-04	1/4	0.50	12.7	3,500	14,000	1.38	35	0.07	P	
618N-05	5/16	0.59	15.0	3,500	14,000	1.97	50	0.10	P	
618N-06	3/8	0.65	16.5	3,500	14,000	2.95	75	0.10	P	
618N-08	1/2	0.85	21.6	3,000	12,000	3.54	90	0.17	P	

618NW 100R18 Non-Conductive Low-Temp Twinline Thermoplastic Pressure Hose 3000-3500psi

Meets or exceeds SAE100R18 / ANSI 92.2 standard
For aerial lift equipment, SAEJ517 less than 50 Microamps leakage at 75,000v for 5 minutes.



- Tube:** Polyester
- Reinforcement:** Synthetic Fiber
- Cover:** Orange low friction high Abrasion and UV resistant urethane, non-perforated
- Temperature:** -50°C to +100°C (-58°F to +212°F)
For use with water and water-based hydraulic fluids to +70°C (+158°F)
- Packaging:** Coils
- Application:** Hydraulics requiring electrical isolation, utility, rescue tools, aerial equipment

PART NUMBER	HOSE I.D.		HOSE O.D.		MAXIMUM WORKING PRESSURE (psi)	MINIMUM BURST PRESSURE (psi)	MINIMUM BEND RADIUS		WEIGHT (lbs/ft)	ONE PIECE COUPLINGS
	(in)	(mm)	(in)	(mm)			(in)	(mm)		
618NW-0202	1/8	0.34	8.5	3,000	14,000	0.98	25	0.08	P	
618NW-0303	3/16	0.41	10.5	3,500	14,000	1.18	30	0.10	P	
618NW-0404	1/4	0.50	12.7	3,500	14,000	1.38	35	0.14	P	
618NW-0505	5/16	0.59	15.0	3,500	14,000	1.97	50	0.20	P	
618NW-0606	3/8	0.65	16.5	3,500	14,000	2.95	75	0.20	P	
618NW-0808	1/2	0.85	21.6	3,000	12,000	3.54	90	0.34	P	

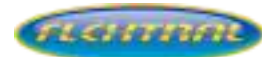

HOSE

621 Thermoplastic Low-Temp

- Tube:** Polyester
- Reinforcement:** Two polyester fiber braids
- Cover:** Black marine grade anti-abrasion polyurethane - perforated
Low friction matte finish - perforated
- Temperature:** -54°C to +100°C (-65°F to +212°F)
- Packaging:** Coils
- Application:** Low temperature hydraulic applications at high pressure



PART NUMBER	HOSE I.D.		HOSE O.D.		MAXIMUM WORKING PRESSURE (psi)	MINIMUM BURST PRESSURE (psi)	MINIMUM BEND RADIUS		WEIGHT (lbs/ft)	ONE PIECE COUPLINGS
	(in)	(mm)	(in)	(mm)			(in)	(mm)		
621-12	3/4		1.24	31.4	3,000	12,000	5.0	125	0.33	Contact Flextral

628 100R8 Thermoplastic

Meets or exceeds SAE100R8, EN-855, ISO3949 - 1/2 wt. of SAE100R2 Hose

- Tube:** Polyester
- Reinforcement:** 1 or 2 high tensile Aramid braids
- Cover:** Black abrasion resistant, UV stabilized, micro perforated Urethane
- Temperature:** -40°C to +100°C (-40°F to +212°F) and fire resistant fluids up to (+70°C/158°F)
- Packaging:** Coils
- Application:** General hydraulics, lubrication, water based fluids



PART NUMBER	HOSE I.D.		HOSE O.D.		MAXIMUM WORKING PRESSURE (psi)	MINIMUM BURST PRESSURE (psi)	MINIMUM BEND RADIUS		WEIGHT (lbs/ft)	ONE PIECE COUPLINGS
	(in)	(mm)	(in)	(mm)			(in)	(mm)		
628-03	3/16		0.39	10.0	5,000	20,000	1.38	35	0.06	P
628-04	1/4		0.46	11.8	5,000	20,000	1.97	50	0.06	P
628-06	3/8		0.63	16.0	4,000	16,000	2.76	70	0.09	P
628-08	1/2		0.81	20.5	3,500	14,000	3.74	95	0.15	P
628-12	3/4		1.04	26.5	2,300	9,200	5.91	150	0.23	P
628-16	1		1.38	35.0	2,100	8,400	7.87	200	0.32	P

Note: Multiline available upon special order.

628N 100R8 Non-Conductive Thermoplastic

Meets or exceeds the requirements of SAE 100R8 / ANSI 92.2 standard for aerial lift equipment

- Tube:** Polyester
- Reinforcement:** 1 or 2 high tensile Aramid braids
- Cover:** Orange abrasion resistant, UV stabilized, urethane, non-perforated
- Temperature:** -40°C to +100°C (-40°F to +212°F) and fire resistant fluids up to (+70°C/158°F)
- Packaging:** Coils
- Application:** Hydraulics requiring electrical isolation, utility, rescue tools, aerial equipment



PART NUMBER	HOSE I.D.		HOSE O.D.		MAXIMUM WORKING PRESSURE (psi)	MINIMUM BURST PRESSURE (psi)	MINIMUM BEND RADIUS		WEIGHT (lbs/ft)	ONE PIECE COUPLINGS
	(in)	(mm)	(in)	(mm)			(in)	(mm)		
628N-03	3/16		0.39	10.0	5,000	20,000	1.38	35.0	0.06	P
628N-04	1/4		0.47	11.8	5,000	20,000	1.97	50.0	0.07	P
628N-06	3/8		0.63	16.0	4,000	18,000	2.76	70.1	0.10	P
628N-08	1/2		0.80	20.3	3,500	14,000	3.74	95.0	0.15	P
628N-12	3/4		1.04	26.5	2,400	9200	5.91	150.1	0.24	P

Note: Multiline available upon special order.



HOSE

625 Thermoplastic Paint One Wire Braid



- Tube:** Polyamide
- Reinforcement:** High tensile 1 wire braid
- Cover:** Blue polyurethane
- Temperature:** -40°C to +100°C (-40°F to +212°F)
- Packaging:** Coils
- Application:** Hydraulic fluids, water, airless paint spray equipment, and a wide range of chemicals

PART NUMBER	HOSE I.D.			MAXIMUM WORKING PRESSURE (psi)	MINIMUM BURST PRESSURE (psi)	MINIMUM BEND RADIUS		WEIGHT (lbs/ft)	ONE PIECE COUPLINGS
	(in)	(in)	(mm)			(in)	(mm)		
625-03	3/16	0.40	10.2	6,700	20,000	1.2	30	0.09	T
625-04	1/4	0.48	12.1	5,800	17,400	1.6	40	0.11	T
625-06	3/8	0.64	16.2	4,350	13,000	2.4	60	0.17	T

Note: Multiline available upon special order.

627 Thermoplastic Paint Two Wire Braid



- Tube:** Polyamide
- Reinforcement:** High tensile 2 wire braid
- Cover:** Blue polyurethane
- Temperature:** -40°C to +100°C (-40°F to +212°F)
- Packaging:** Coils
- Application:** Hydraulic fluids, water, airless paint spray equipment, and a wide range of chemicals

PART NUMBER	HOSE I.D.			MAXIMUM WORKING PRESSURE (psi)	MINIMUM BURST PRESSURE (psi)	MINIMUM BEND RADIUS		WEIGHT (lbs/ft)	ONE PIECE COUPLINGS
	(in)	(in)	(mm)			(in)	(mm)		
627-04	1/4	0.54	13.7	7,700	23,200	1.6	40	0.20	Contact Flextral
627-06	3/8	0.68	17.2	6,300	19,000	2.4	60	0.27	Contact Flextral

Note: Multiline available upon special order.

907PW Specialty Food/Beverage Hose



Meets or exceeds the requirements of SAE 100R7 and FDA title 21

- Tube:** Food grade plasticizer free polymer
- Reinforcement:** Synthetic Fiber
- Cover:** Aqua abrasion resistant perforated urethane
- Temperature:** -40° C to +66° C (-40° F to +150° F)
- Packaging:** Coils
- Application:** Pure, deionized, distilled, potable water transfer / CO₂, beverage, food transfer/ urethane and moisture sensitive chemical transfer and spray

PART NUMBER	HOSE I.D.			MAXIMUM WORKING PRESSURE (psi)	MINIMUM BURST PRESSURE (psi)	MINIMUM BEND RADIUS		WEIGHT (lbs/ft)	ONE PIECE COUPLINGS
	(in)	(in)	(mm)			(in)	(mm)		
907PW-04	1/4	0.50	12.7	2,750	11,000	1.57	39.9	0.067	P
907PW-06	3/8	0.66	16.4	2,250	9,000	1.96	49.9	0.095	P
907PW-08	1/2	0.80	20.3	2,000	8,000	2.95	74.9	0.133	P

Note: Custom colors available upon request
Note: Multiline available upon special order.



HOSE

908BA Thermoplastic Breathing Air Fill Hose

Meets or exceeds standard CGA G-7.1-2004 grade E breathing air, NFPA 1901, NFPA 1961 and European Directive 2002/72/EL



- Tube:** FDA/ED Thermoplastic polymer
- Reinforcement:** Aramid fiber
- Cover:** Grey abrasion resistant perforated urethane (*other colors available upon request*)
- Temperature:** -40°C to +100°C (-40°F to +212°F)
Max. working temperature of air, water, and fluids containing water: +70°C (+158°F)
- Packaging:** Reels
- Application:** Air compressor stations, SCUBA refilling station, mobile, cascade systems

PART NUMBER	HOSE I.D.	HOSE O.D.		MAXIMUM WORKING PRESSURE	MINIMUM BURST PRESSURE	MINIMUM BEND RADIUS		WEIGHT	ONE PIECE
	(in)	(in)	(mm)			(psi)	(psi)		(in)
908BA-04	1/4	0.50	12.7	6,000	24,000	1.97	50	0.07	P
908BA-06	3/8	0.65	16.5	6,000	24,000	2.95	75	0.10	P

Caution: Not for use as part of SCUBA systems or for use with pure oxygen and hydrogen transfer
 Note: Multiline available upon special order.

912 Marine Steering Hose

- Tube:** Polyester
- Reinforcement:** Polyester
- Cover:** Black marine grade urethane
- Temperature:** -40°C to +100°C (-40°F to +212°F)
- Packaging:** Reels
- Application:** Hydraulic marine steering systems



PART NUMBER	HOSE I.D.	HOSE O.D.		MAXIMUM WORKING PRESSURE	MINIMUM BURST PRESSURE	MINIMUM BEND RADIUS		WEIGHT	ONE PIECE
	(in)	(in)	(mm)			(psi)	(psi)		(in)
912-05	5/16	0.48	12.2	1,500	6,000	2.6	66	0.054	MS05-06FMS-BR

Note: Multiline available upon special order.

915 Quick Response Marine Steering Hose

- Tube:** Polyester
- Reinforcement:** 1 high tensile aramid fiber
- Cover:** Black marine grade urethane
- Temperature:** -40°C to +100°C (-40°F to +212°F)
- Packaging:** Reels
- Application:** Designed for high performance steering systems where immediate steer feedback response is required.



PART NUMBER	HOSE I.D.	HOSE O.D.		MAXIMUM WORKING PRESSURE	MINIMUM BURST PRESSURE	MINIMUM BEND RADIUS		WEIGHT	ONE PIECE
	(in)	(in)	(mm)			(psi)	(psi)		(in)
915-05	5/16	0.48	12.2	1,500	6,000	2.6	66	0.054	MS05-06FMS-BR

Note: Multiline available upon special order.



HOSE

HOSE HYDRAULIC BRAIDED

HX 100R4 Suction / Return Hose

Meets or exceeds the requirements of SAE 100R4

- Tube: Seamless, black, oil and heat resistant synthetic rubber
- Reinforcement: Textile braided with spiral wire to prevent collapsing
- Cover: Black synthetic oil and heat resistant rubber, MSHA approved
- Temperature: -40°C to +100°C (-40°F to +212°F)
- Packaging: 100' coils
- Application: Petroleum and water base hydraulic fluids in suction lines or in low pressure return lines



PART NUMBER	HOSE I.D.		HOSE O.D.		MAXIMUM WORKING PRESSURE (psi)	MINIMUM BURST PRESSURE (psi)	MINIMUM BEND RADIUS		WEIGHT (lbs/ft)	VACUUM HG (in)	ONE PIECE COUPLINGS
	(in)	(in)	(mm)	(in)			(mm)				
HX-12	3/4	1.26	34.9	300	1,200	4.9	125	0.49	28	E, N, HA	
HX-16	1	1.47	41.3	250	1,000	5.9	150	0.57	28	E, N, HA	
HX-20	1 1/4	1.77	50.8	200	800	7.8	200	0.75	28	E, N, HA	
HX-24	1 1/2	2.05	57.2	150	600	10.0	255	0.98	28	E, N, HA	
HX-32	2	2.52	69.9	100	400	11.8	300	1.23	28	E, N, HA	
HX-40	2 1/2	3.03	77	58	232	14.0	356	1.55	28	HA	
HX-48	3	3.54	90	58	232	18.0	457	1.92	28	HA	

HH 100R4 High-Temp Suction / Return Hose

Meets or exceeds the requirements of SAE 100R4

- Tube: Seamless, black, oil and heat resistant synthetic rubber
- Reinforcement: Two textile braids with spiral wire to prevent collapsing
- Cover: Black synthetic oil and heat resistant rubber, MSHA approved
- Temperature: -40°C to +135°C (-40°F to +275°F)
- Packaging: 100' coils
- Application: Petroleum and water base hydraulic fluids in suction lines or in low pressure return lines



PART NUMBER	HOSE I.D.		HOSE O.D.		MAXIMUM WORKING PRESSURE (psi)	MINIMUM BURST PRESSURE (psi)	MINIMUM BEND RADIUS		WEIGHT (lbs/ft)	VACUUM HG (in)	ONE PIECE COUPLINGS
	(in)	(in)	(mm)	(in)			(mm)				
HH-12	3/4	1.18	30	315	1,235	2.4	60	0.42	28	N, HA	
HH-16	1	1.46	37	255	1,035	3.2	80	0.58	28	N, HA	
HH-20	1 1/4	1.73	44	210	825	3.9	100	0.70	28	N, HA	
HH-24	1 1/2	1.97	50	150	615	4.9	125	0.91	28	N, HA	
HH-32	2	2.48	63	105	420	5.9	150	1.17	28	N, HA	
HH-40	2 1/2	3.13	79.5	105	420	7.9	200	1.61	28	HA	
HH-48	3	3.62	92	200	800	9.4	240	1.95	28	HA	
HH-56	3 1/2	4.25	108	200	800	11.0	280	2.48	28	HA	
HH-64	4	4.73	120	200	800	12.6	320	2.78	28	HA	



HOSE

FX 100R5 Textile Cover

Meets or exceeds performance requirements of SAE 100R5 and D.O.T. FMVSS 106



- Tube: Seamless, black, oil and heat resistant synthetic rubber
- Reinforcement: One braid of synthetic yarn and one braid of steel wire
- Cover: Black, impregnated textile braid, oil and mildew resistant, MSHA approved
- Temperature: -40°C to +100°C (-40°F to +212°F)
- Packaging: 3/16" - 1 1/8" reels, 1 3/8" and higher in coils
- Application: Used for high temperature, HYDRAULIC BRAIDED hydraulic applications, diesel fuel and lubricating oils.

PART NUMBER	HOSE I.D.		HOSE O.D.		MAXIMUM WORKING PRESSURE (psi)	MINIMUM BURST PRESSURE (psi)	MINIMUM BEND RADIUS		WEIGHT (lbs/ft)	ONE PIECE COUPLINGS	RE-USABLE COUPLINGS
	(in)	(in)	(mm)	(mm)			(in)	(mm)			
FX-04	3/16	0.52	13.2		3,000	12,000	3.0	76	0.15	F	5R
FX-05	1/4	0.58	14.8		3,000	12,000	3.4	86	0.18	F	5R
FX-06	5/16	0.68	17.1		2,250	9,000	4.0	102	0.22	F	5R
FX-08	13/32	0.77	19.5		2,000	8,000	4.6	117	0.30	F	5R
FX-10	1/2	0.92	23.4		1,750	7,000	5.5	140	0.37	F	5R
FX-12	5/8	1.08	27.4		1,500	6,000	6.5	165	0.45	F	5R
FX-16	7/8	1.24	31.4		800	3,200	7.4	187	0.47	F	5R
FX-20	1 1/8	1.50	38.1		625	2,500	9.0	229	0.58	F	5R
FX-24	1 3/8	1.75	44.4		500	2,000	10.5	267	0.73	F	5R
FX-32	1 13/16	2.22	56.4		350	1,400	13.3	337	0.90	F	5R

FH 100R5 Textile Cover - Hi-Temp

Meets or exceeds performance requirements of SAE 100R5 and D.O.T. FMVSS 106



- Tube: Seamless, black, oil and heat resistant synthetic rubber
- Reinforcement: One braid of synthetic yarn and one braid of steel wire
- Cover: Blue, impregnated textile braid, oil and mildew resistant, MSHA approved
- Temperature: -40°C to +149°C (-40°F to +300°F) - petroleum bases fluids
-40°C to +107°C (-40°F to +225°F) - water/oil emulsions or water glycol solutions
-40°C to +42°C (-40°F to +180°F) - phosphate ester fluids
- Packaging: 3/16" - 1 1/8" reels, 1 3/8" and higher in coils
- Application: Used for high temperature, HYDRAULIC BRAIDED hydraulic applications, diesel fuel and lubricating oils, SAE J1942/1 USCG - H accepted.

PART NUMBER	HOSE I.D.		HOSE O.D.		MAXIMUM WORKING PRESSURE (psi)	MINIMUM BURST PRESSURE (psi)	MINIMUM BEND RADIUS		WEIGHT (lbs/ft)	ONE PIECE COUPLINGS	RE-USABLE COUPLINGS
	(in)	(in)	(mm)	(mm)			(in)	(mm)			
FH-04	3/16	0.52	13.2		3,000	12,000	3.0	76	0.15	F	5R
FH-05	1/4	0.58	14.8		3,000	12,000	3.4	86	0.18	F	5R
FH-06	5/16	0.68	17.1		2,250	9,000	4.0	102	0.22	F	5R
FH-08	13/32	0.77	19.5		2,000	8,000	4.5	117	0.30	F	5R
FH-10	1/2	0.92	23.4		1,750	7,000	5.5	140	0.37	F	5R
FH-12	5/8	1.08	27.4		1,500	6,000	6.5	165	0.45	F	5R
FH-16	7/8	1.24	31.4		800	3,200	7.4	187	0.47	F	5R
FH-20	1 1/8	1.50	38.1		625	2,500	9.0	229	0.58	F	5R
FH-24	1 3/8	1.75	44.4		500	2,000	10.5	267	0.73	F	5R
FH-32	1 13/16	2.22	56.4		350	1,400	13.3	337	0.90	F	5R

AXT 100R17

Meets or exceeds the requirements of SAE 100R17

- Tube: Nitrile
- Reinforcement: 1/4" thru 3/8" One wire braid, 1/2" thru 1" Two wire braids
- Cover: Black, oil, abrasion and weather resistant synthetic rubber, MSHA approved
- Temperature: -40°C to +100°C (-40°F to +212°F), intermittent use up to +125°C (+257°F)
- Packaging: Reels
- Application: Petroleum based hydraulic fluids, gasoline, water, diesel fuels and lubricating oils, biodegradeable hydraulic oil, fire resistant synthetic polyol esters, SAE J1942/1 USCG - H accepted.



PART NUMBER	HOSE I.D.		HOSE O.D.		MAXIMUM WORKING PRESSURE (psi)	MINIMUM BURST PRESSURE (psi)	MINIMUM BEND RADIUS		WEIGHT (lbs/ft)	ONE PIECE COUPLINGS
	(in)	(mm)	(in)	(mm)			(in)	(mm)		
AXT-04	1/4	12.2	0.48	12.2	3,000	12,000	2.0	51	0.12	E
AXT-06	3/8	15.5	0.61	15.5	3,000	12,000	2.6	65	0.19	E
AXT-08	1/2	20.7	0.81	20.7	3,000	12,000	3.5	90	0.24	E
AXT-10	5/8	23.8	0.94	23.8	3,000	12,000	3.9	100	0.48	E, N
AXT-12	3/4	27.7	1.10	27.7	3,000	12,000	5.0	127	0.56	E, N
AXT-16	1	36.0	1.42	36.0	3,000	12,000	5.9	150	0.83	E, N

AXT 100R17 Twinline

Meets or exceeds the requirements of SAE 100R17

- Tube: Nitrile
- Reinforcement: 1/4" thru 3/8" One wire braid, 1/2" thru 1" Two wire braids
- Cover: Black, oil, abrasion and weather resistant synthetic rubber, MSHA approved
- Temperature: -40°C to +100°C (-40°F to +212°F), intermittent use up to +125°C (+257°F)
- Packaging: Reels
- Application: Petroleum based hydraulic fluids, gasoline, water, diesel fuels and lubricating oils, biodegradeable hydraulic oil, fire resistant synthetic polyol esters, SAE J1942/1 USCG - H accepted.



PART NUMBER	HOSE I.D.		HOSE O.D.		MAXIMUM WORKING PRESSURE (psi)	MINIMUM BURST PRESSURE (psi)	MINIMUM BEND RADIUS		WEIGHT (lbs/ft)	ONE PIECE COUPLINGS
	(in)	(mm)	(in)	(mm)			(in)	(mm)		
AXT-0404T	1/4	12.2	0.48	12.2	3,000	12,000	2.0	51	0.24	E
AXT-0606T	3/8	15.5	0.61	15.5	3,000	12,000	2.6	65	0.38	E
AXT-0808T	1/2	20.7	0.81	20.7	3,000	12,000	3.5	90	0.48	E



HOSE

AXT-PS 100R17 PRO-SHIELD®

Meets or exceeds the requirements of SAE 100R17



- Tube: Nitrile
- Reinforcement: 1/4" thru 3/8" One wire braid, 1/2" thru 1" Two wire braids
- Cover: Black, oil, high abrasion and weather resistant synthetic rubber, MSHA approved
Flextral ProShield cover is designed and tested to achieve up to double the abrasion resistance of standard industry covers.
- Temperature: -40°C to +100°C (-40°F to +212°F), intermittent use up to +125°C (+257°F)
- Packaging: Reels
- Application: High abrasion applications for petroleum based hydraulic fluids, gasoline, water, diesel fuels and lubricating oils, biodegradable hydraulic oil, fire resistant synthetic polyol esters, SAE J1942/1 USCG - H accepted.

PART NUMBER	HOSE I.D.		HOSE O.D.		MAXIMUM WORKING PRESSURE (psi)	MINIMUM BURST PRESSURE (psi)	MINIMUM BEND RADIUS		WEIGHT (lbs/ft)	ONE PIECE COUPLINGS
	(in)	(mm)	(in)	(mm)			(in)	(mm)		
AXT-04PS	1/4	12.2	0.48	12.2	3,000	12,000	2.0	51	0.12	E
AXT-06PS	3/8	15.5	0.61	15.5	3,000	12,000	2.6	65	0.19	E
AXT-08PS	1/2	20.7	0.81	20.7	3,000	12,000	3.5	90	0.24	E
AXT-10PS	5/8	23.8	0.94	23.8	3,000	12,000	3.9	100	0.48	E, N
AXT-12PS	3/4	27.7	1.10	27.7	3,000	12,000	5.0	127	0.56	E, N
AXT-16PS	1	36.0	1.42	36.0	3,000	12,000	5.9	150	0.83	E, N

AXT-HT 100R17 HIGH TEMPERATURE

Meets or exceeds the requirements of SAE 100R17



- Tube: Nitrile
- Reinforcement: 1/4" thru 3/8" One wire braid, 1/2" thru 1" Two wire braids
- Cover: Blue, High temperature synthetic rubber cover
- Temperature: -40°C to +135°C (-40°F to +275°F)
- Packaging: Reels
- Application: High temperature applications for petroleum based hydraulic fluids, gasoline, water, diesel fuels and lubricating oils, biodegradable hydraulic oil, fire resistant synthetic polyesters, SAE J1942/1 USCG - H accepted.

PART NUMBER	HOSE I.D.		HOSE O.D.		MAXIMUM WORKING PRESSURE (psi)	MINIMUM BURST PRESSURE (psi)	MINIMUM BEND RADIUS		WEIGHT (lbs/ft)	ONE PIECE COUPLINGS
	(in)	(mm)	(in)	(mm)			(in)	(mm)		
AXT-04HT	1/4	12.2	0.48	12.2	3,000	12,000	2.0	51	0.12	E
AXT-06HT	3/8	15.5	0.61	15.5	3,000	12,000	2.6	65	0.19	E
AXT-08HT	1/2	20.7	0.81	20.7	3,000	12,000	3.5	90	0.24	E
AXT-10HT	5/8	23.8	0.94	23.8	3,000	12,000	3.9	100	0.48	E, N
AXT-12HT	3/4	27.7	1.10	27.7	3,000	12,000	5.0	127	0.56	E, N
AXT-16HT	1	36.0	1.42	36.0	3,000	12,000	5.9	150	0.83	E, N

EX 2SN Two Wire Braid Hose

Meets or exceeds the requirements of SAE 100R2AT-EN853
DIN 20022 2SN-ISO 1436 Type 2



- Tube: Nitrile
- Reinforcement: Two braids of high tensile steel wire
- Cover: Black, oil, abrasion and weather resistant synthetic rubber, MSHA approved
- Temperature: -40°C to +100°C (-40°F to +212°F), intermittent use up to +125°C (+257°F)
- Packaging: 1/4" - 1" Reels, 1 1/4" - 2" Coils
- Application: Petroleum based hydraulic fluids, gasoline, water, diesel fuels and lubricating oils, biodegradable hydraulic oil, fire resistant synthetic polyol esters, SAE J1942/1 USCG - H accepted.

PART NUMBER	HOSE I.D.	HOSE O.D.		MAXIMUM WORKING PRESSURE	MINIMUM BURST PRESSURE	MINIMUM BEND RADIUS		WEIGHT	ONE PIECE
	(in)	(in)	(mm)			(psi)	(psi)		(in)
EX-03	3/16	0.52	13.3	6,020	24,080	3.5	90	0.20	E
EX-04	1/4	0.56	14.3	5,805	23,220	3.9	100	0.26	E
EX-05	5/16	0.63	15.9	5,080	20,320	4.5	115	0.29	E
EX-06	3/8	0.72	18.3	5,000	20,000	5.0	130	0.37	E, N
EX-08	1/2	0.84	21.3	4,000	16,000	7.1	180	0.44	E, N
EX-10	5/8	0.96	24.5	3,625	14,500	7.9	200	0.51	E, N
EX-12	3/4	1.12	28.5	3,120	12,480	9.5	240	0.63	E, N
EX-16	1	1.46	37.1	2,395	9,580	11.8	300	0.88	E, N
EX-20	1 1/4	1.86	47.3	1,815	7,260	16.5	420	1.27	E, N
EX-24	1 1/2	2.11	53.7	1,305	5,220	19.7	500	1.41	E, N
EX-32	2	2.62	66.7	1,160	4,640	24.8	630	1.85	E, N
EX-40	2 1/2	3.14	79.8	1,000	4,000	29.9	760	2.56	HA
EX-48	3	3.61	91.9	725	2,900	35.4	900	2.71	HA



HOSE

GX 1SN One Wire Braid Hose

Meets or exceeds the requirements of SAE 100R1AT-EN853
DIN 20022 1SN-ISO 1436 Type 1



- Tube: Nitrile
- Reinforcement: One braid of high tensile steel wire
- Cover: Black, oil, abrasion and weather resistant synthetic rubber, MSHA approved
- Temperature: -40°C to +100°C (-40°F to +212°F), intermittent use up to +125°C (+257°F)
- Packaging: 3/16" - 1" Reels, 1 1/4" - 2" Coils
- Application: Petroleum based hydraulic fluids, gasoline, water, diesel fuels and lubricating oils, biodegradeable hydraulic oil, fire resistant synthetic polyesters.

PART NUMBER	HOSE I.D.	HOSE O.D.		MAXIMUM WORKING PRESSURE	MINIMUM BURST PRESSURE	MINIMUM BEND RADIUS		WEIGHT	ONE PIECE
	(in)	(in)	(mm)			(psi)	(psi)		(in)
GX-03	3/16	0.46	11.6	3,625	14,500	3.5	90	0.12	E
GX-04	1/4	0.52	13.2	3,265	13,060	4.0	100	0.15	E
GX-05	5/16	0.58	14.8	3,120	12,480	4.5	115	0.17	E
GX-06	3/8	0.68	17.2	2,610	10,440	5.0	130	0.23	E, N
GX-08	1/2	0.80	20.4	2,320	9,280	7.0	180	0.28	E, N
GX-10	5/8	0.93	23.5	1,885	7,540	8.0	200	0.32	E, N
GX-12	3/4	1.08	27.5	1,525	6,100	9.5	240	0.40	E, N
GX-16	1	1.39	35.4	1,275	5,100	12.0	300	0.59	E, N
GX-20	1 1/4	1.71	43.5	915	3,660	16.5	420	0.82	E, N
GX-24	1 1/2	1.97	50.0	725	2,900	20.0	500	0.95	E, N
GX-32	2	2.50	63.6	580	2,320	25.0	630	1.30	E, N

PX250 2SC Two Wire Braid Hose

Meets or exceeds the requirements of SAE 100R16 and EN857 2SC
DIN 20022 2SN-ISO 1436 Type 2



- Tube: Nitrile
- Reinforcement: Two braids of high tensile steel wire
- Cover: Black, oil, high abrasion and weather resistant synthetic rubber, MSHA approved
- Temperature: -40°C to +100°C (-40°F to +212°F)
- Packaging: ¼" - 1" Reels
- Application: Petroleum based hydraulic fluids, gasoline, water, diesel fuels and lubricating oils, biodegradeable hydraulic oil, fire resistant synthetic polyol esters, SAE J1942/1 USCG - H accepted.

PART NUMBER	HOSE I.D.	HOSE O.D.		MAXIMUM WORKING PRESSURE (psi)	MINIMUM BURST PRESSURE (psi)	MINIMUM BEND RADIUS		WEIGHT (lbs/ft)	ONE PIECE
	(in)	(in)	(mm)			(in)	(mm)		COUPLINGS
PX250-04	¼	0.53	13.4	5,805	23,220	2.0	50	0.19	E
PX250-05	5/16	0.59	15.0	5,080	20,320	2.2	55	0.23	E
PX250-06	3/8	0.67	17.1	5,000	20,000	2.6	65	0.29	E, N
PX250-08	½	0.81	20.7	4,250	17,000	3.5	90	0.39	E, N
PX250-10	5/8	0.94	23.8	3,625	14,500	3.9	100	0.47	E, N
PX250-12	¾	1.09	27.7	3,125	12,500	4.7	120	0.55	E, N
PX250-16	1	1.42	36.0	3,000	12,000	5.9	150	0.83	E, N
PX250-20	1¼	1.70	43.2	2,250	9,000	8.25	210	1.09	E, N

PX250 Twinline 2SC Two Wire Braid Hose

Meets or exceeds the requirements of SAE 100R16 and EN857 2SC
DIN 20022 2SN-ISO 1436 Type 2



- Tube: Nitrile
- Reinforcement: Two braids of high tensile steel wire
- Cover: Black, oil, high abrasion and weather resistant synthetic rubber, MSHA approved
- Temperature: -40°C to +100°C (-40°F to +212°F)
- Packaging: ¼" - 1" Reels
- Application: Petroleum based hydraulic fluids, gasoline, water, diesel fuels and lubricating oils, biodegradeable hydraulic oil, fire resistant synthetic polyol esters, SAE J1942/1 USCG - H accepted.

PART NUMBER	HOSE I.D.	HOSE O.D.		MAXIMUM WORKING PRESSURE (psi)	MINIMUM BURST PRESSURE (psi)	MINIMUM BEND RADIUS		WEIGHT (lbs/ft)	ONE PIECE
	(in)	(in)	(mm)			(in)	(mm)		COUPLINGS
PX250-0404T	¼	0.53	13.4	5,805	23,220	2.0	50	0.38	E
PX250-0606T	3/8	0.67	17.1	5,000	20,000	2.6	65	0.58	E, N
PX250-0808T	½	0.81	20.7	4,250	17,000	3.5	90	0.78	E, N

* Other size variations are available upon request.



HOSE

PX250-PS 2SC PRO-SHIELD®

Meets or exceeds the requirements of SAE 100R16 and EN857 2SC
DIN 20022 2SN-ISO 1436 Type 2



- Tube: Nitrile
- Reinforcement: Two braids of high tensile steel wire
- Cover: Black, oil, high abrasion and weather resistant synthetic rubber, MSHA approved
Flextral ProShield cover is designed and tested to achieve up to double the abrasion resistance of standard industry covers.
- Temperature: -40°C to +100°C (-40°F to +212°F)
- Packaging: 1/4" - 1" Reels
- Application: High abrasion applications, petroleum based hydraulic fluids, gasoline, water, diesel fuels and lubricating oils, biodegradable hydraulic oil, fire resistant synthetic polyol esters, SAE J1942/1 USCG - H accepted.

PART NUMBER	HOSE I.D.		HOSE O.D.		MAXIMUM WORKING PRESSURE (psi)	MINIMUM BURST PRESSURE (psi)	MINIMUM BEND RADIUS		WEIGHT (lbs/ft)	ONE PIECE COUPLINGS
	(in)	(mm)	(in)	(mm)			(in)	(mm)		
PX250-04PS	1/4	6.35	0.53	13.4	5,805	23,220	2.0	50	0.19	E
PX250-05PS	5/16	7.94	0.59	15.0	5,080	20,320	2.2	55	0.23	E
PX250-06PS	3/8	9.53	0.67	17.1	5,000	20,000	2.6	65	0.29	E, N
PX250-08PS	1/2	12.7	0.81	20.7	4,250	17,000	3.5	90	0.39	E, N
PX250-10PS	5/8	15.88	0.94	23.8	3,625	14,500	3.9	100	0.47	E, N
PX250-12PS	3/4	19.05	1.09	27.7	3,125	12,500	4.7	120	0.55	E, N
PX250-16PS	1	25.4	1.42	36.0	3,000	12,000	5.9	150	0.83	E, N

PX300 Extended Service

Exceeds the requirements of SAE 100R16 and EN857 2SC DIN 20022 2SN-ISO 1436 Type 2



- Tube: Nitrile
- Reinforcement: Two braids of ultra high tensile steel wire
- Cover: Smooth, black, high abrasion, oil and weather resistant synthetic rubber, MSHA approved.
- Temperature: -54°C to +121°C (-65°F to +250°F)
- Packaging: Reels/Coils
- Application: Petroleum based hydraulic fluids, water, diesel fuel, lubricating oils, biodegradable hydraulic oils, fire resistant synthetic Polyol Esters. SAE J1942/1 USCG - H accepted.

PART NUMBER	HOSE I.D.		HOSE O.D.		MAXIMUM WORKING PRESSURE (psi)	MINIMUM BURST PRESSURE (psi)	MINIMUM BEND RADIUS		WEIGHT (lbs/ft)	ONE PIECE COUPLINGS
	(in)	(mm)	(in)	(mm)			(in)	(mm)		
PX300-04	1/4	6.35	0.53	13.5	5,800	23,200	1.9	48	0.20	E
PX300-06	3/8	9.53	0.68	17.3	5,000	20,000	2.5	63	0.30	E, N
PX300-08	1/2	12.7	0.80	20.3	4,395	17,580	3.3	85	0.36	E, N
PX300-10	5/8	15.88	0.97	24.7	3,700	14,800	3.9	98	0.48	E, N
PX300-12	3/4	19.05	1.12	28.5	3,190	12,760	4.5	115	0.61	E, N
PX300-16	1	25.4	1.41	35.8	3,045	12,180	5.7	145	0.84	E, N

* PX300 has been tested and approved for 1,000,000 impulse cycles at 133% of working pressure at 250°F.

NT300 Extended Service

Exceeds the requirements of SAE 100R12 - EN856 accepted



Tube: Nitrile

Reinforcement: High tensile steel four spiral wire

Cover: Synthetic rubber, high abrasion resistant, meets requirements of MSHA fire resistance standards

Temperature: -54°C to +121°C (-65°F to +250°F)

Packaging: Coils

Application: NT300 is ideal for hydraulic systems with petroleum, polyol ester, or water/glycol based fluids. The hose is very flexible with a bending radius less than standard spiral hose and a high abrasion resistant cover. Hose is accepted for hydraulic service. SAE J1942/1 USCG - H accepted.

PART NUMBER	HOSE I.D.		HOSE O.D.		MAXIMUM WORKING PRESSURE (psi)	MINIMUM BURST PRESSURE (psi)	MINIMUM BEND RADIUS		WEIGHT (lb/ft)	ONE PIECE Non-Skive	ONE PIECE Skive
	(in)	(in)	(mm)	(mm)			(in)	(mm)		COUPLINGS	COUPLINGS
NT300-06	3/8	0.80	20.3		6,000	24,000	4.9	125	0.42	N	
NT300-08	1/2	0.87	22.2		5,000	20,000	4.3	110	0.46	N	
NT300-10	5/8	1.04	26.4		5,000	20,000	5.5	140	0.64	N	
NT300-12	3/4	1.14	29.0		5,000	20,000	6.7	170	0.68	N, V	
NT300-16	1	1.44	36.6		5,500	22,000	8.7	220	1.25	N, V	
NT300-20	1 1/4	1.74	44.3		5,000	20,000	15.0	380	1.55	N	VS
NT300-24	1 1/2	2.01	51.1		4,300	17,200	17.7	450	1.86	N	VS
NT300-32	2	2.60	66.0		3,600	14,400	19.7	500	2.97	N	VS

NZ Four Spiral Hose

Meets or exceeds the requirements of SAE 100R12 - EN856

Tube: Nitrile

Reinforcement: Four spirals of high tensile steel

Cover: Black, oil, abrasion and weather resistant synthetic rubber, MSHA approved

Temperature: -40°C to +121°C (-40°F to +250°F)

Packaging: Coils

Application: Hydraulic systems with petroleum or water/glycol based fluids. For fuel and lubricating oils.



PART NUMBER	HOSE I.D.		HOSE O.D.		MAXIMUM WORKING PRESSURE (psi)	MINIMUM BURST PRESSURE (psi)	MINIMUM BEND RADIUS		WEIGHT (lbs/ft)	ONE PIECE Non-Skive	ONE PIECE Skive
	(in)	(in)	(mm)	(mm)			(in)	(mm)		COUPLINGS	COUPLINGS
NZ-08	1/2	0.96	24.4		6,000	24,000	9.1	230	0.58	N, V	
NZ-12	3/4	1.26	32.0		6,100	24,400	11.0	280	1.03	N, V	
NZ-16	1	1.51	38.4		5,500	22,000	13.3	340	1.44	N, V	
NZ-20	1 1/4	1.78	45.2		5,000	20,000	18.1	460	1.68	N	
NZ-24	1 1/2	2.09	53.0		4,300	17,200	22.0	560	2.24	N	VS
NZ-32	2	2.66	67.6		3,600	14,400	27.5	700	3.08	N	VS

HOSE

VT300 Extended Service

Meets or exceeds the requirements of SAE 100R13



- Tube: Nitrile
- Reinforcement: High tensile steel six spiral wire
- Cover: Synthetic rubber, high abrasion resistant, meets requirements of MSHA fire resistant standards
- Temperature: -48°C to +121°C (-55°F to +250°F)
- Packaging: Coils
- Application: VT300 is ideal for hydraulic systems with petroleum, polyolester, or water/glycol based fluids. The hose is very flexible with a bending radius less than standard spiral hose and a high abrasion resistant cover. Hose is accepted for hydraulic service. SAE J1942/1 USCG – H accepted.

PART NUMBER	HOSE I.D.		HOSE O.D.		MAXIMUM WORKING PRESSURE (psi)	MINIMUM BURST PRESSURE (psi)	MINIMUM BEND RADIUS		WEIGHT (lb/ft)	ONE PIECE Skive COUPLINGS
	(in)	(in)	(in)	(mm)			(in)	(mm)		
VT300-20	1¼	1.92	48.8	5,000	20,000	11.0	280	2.44	VS	
VT300-24	1½	2.19	55.6	5,000	20,000	13.0	330	3.20	VS	
VT300-32	2	2.80	71.1	5,000	20,000	16.5	420	4.20	VS	

VZ 100R13 Six Spiral Wire Hose

Meets or exceeds the requirements of SAE 100R13



- Tube: Nitrile
- Reinforcement: 1¼" thru 2" 6 spirals of high tensile steel
- Cover: Black, oil, abrasion and weather resistant synthetic rubber, MSHA approved
- Temperature: -40°C to +121°C (-40°F to +250°F)
- Packaging: Coils
- Application: Hydraulic systems with petroleum or water/glycol based fluids. For fuel and lubricating oils.

PART NUMBER	HOSE I.D.		HOSE O.D.		MAXIMUM WORKING PRESSURE (psi)	MINIMUM BURST PRESSURE (psi)	MINIMUM BEND RADIUS		WEIGHT (lbs/ft)	ONE PIECE Skive COUPLINGS
	(in)	(in)	(in)	(mm)			(in)	(mm)		
VZ-20	1¼	1.96	49.3	5,000	20,000	16.5	420	2.45	VS	
VZ-24	1½	2.26	57.6	5,000	20,000	19.6	500	3.35	VS	
VZ-32	2	2.82	71.6	5,000	20,000	24.8	630	4.37	VS	

SX Four Spiral Wire Hose

Meets or exceeds the requirements of DIN 20023-4SP

- Tube: Nitrile
- Reinforcement: Four spirals of high tensile steel wire
- Cover: Black, oil, abrasion and weather resistant synthetic rubber, MSHA approved
- Temperature: -40°C to +100°C (-40°F to +212°F), intermittent use up to +125°C (+257°F)
- Packaging: Coils
- Application: Petroleum based hydraulic fluids, gasoline, water, diesel fuels and lubricating oils.



PART NUMBER	HOSE I.D.		HOSE O.D.		MAXIMUM WORKING PRESSURE (psi)	MINIMUM BURST PRESSURE (psi)	MINIMUM BEND RADIUS		WEIGHT (lbs/ft)	ONE PIECE Skive
	(in)	(in)	(in)	(mm)			(in)	(mm)		COUPLINGS*
SX-08	1/2	.97	24.6		6,000	24,000	9.0	229	0.59	N, V

* Hose must be skived with all couplings.

QX Four Spiral Hose (Half Bend)

Meets or exceeds the requirements of SAE 100R12 - EN856
(Half the bend radius of SAE100R12)

- Tube: Nitrile
- Reinforcement: Four spirals of high tensile wire
- Cover: Black, oil, abrasion and weather resistant synthetic rubber, MSHA approved
- Temperature: -40°C to +121°C (-40°F to +250°F)
- Packaging: Coils
- Application: Locations that require greater flexibility.



PART NUMBER	HOSE I.D.		HOSE O.D.		MAXIMUM WORKING PRESSURE (psi)	MINIMUM BURST PRESSURE (psi)	MINIMUM BEND RADIUS		WEIGHT (lbs/ft)	ONE PIECE Non-Skive
	(in)	(in)	(in)	(mm)			(in)	(mm)		COUPLINGS
QX-06	3/8	0.76	19.2		4,060	16,240	2.6	65	.40	N, V
QX-08	1/2	0.89	22.6		4,060	16,240	3.5	90	.54	N, V
QX-10	5/8	1.06	26.8		4,060	16,240	3.9	100	.74	N
QX-12	3/4	1.20	30.4		4,060	16,240	4.7	120	.94	N, V
QX-16	1	1.50	38.1		4,060	16,240	5.9	150	1.34	N

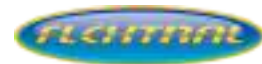

HOSE

CX Six Spiral Wire Hose

Meets or exceeds the requirements of SAE 100R15



- Tube: Nitrile
- Reinforcement: Six spiral layers of high tensile steel wire
- Cover: Black, oil, abrasion and weather resistant synthetic rubber, MSHA approved
- Temperature: -40°C to +121°C (-40°F to +250°F)
- Packaging: Coils
- Application: Hydraulic systems with petroleum or water/glycol based fluids and for fuel and lubricating oils. Available in a "Green" environmental version suitable for use with biodegradable hydraulic oils based on rapeseed and synthetic polyesters. Good for diesel fuel.

PART NUMBER	HOSE I.D.		HOSE O.D.		MAXIMUM WORKING PRESSURE (psi)	MINIMUM BURST PRESSURE (psi)	MINIMUM BEND RADIUS		WEIGHT (lbs/ft)	ONE PIECE Non-Skive	ONE PIECE Skive
	(in)	(in)	(mm)	(mm)			(in)	(mm)		COUPLINGS	COUPLINGS
CX-06	3/8	0.69	17.5	6,000	24,000	6.0	150	0.51	V		
CX-08	1/2	0.80	20.2	6,000	24,000	8.0	200	0.59	V		
CX-12	3/4	1.20	30.7	6,000	24,000	11.0	280	1.09	V		
CX-16	1	1.52	38.7	6,000	24,000	11.8	300	1.46	V		
CX-20	1 1/4	1.97	50.0	6,000	24,000	15.7	400	2.40		VS	
CX-24	1 1/2	2.27	57.6	6,000	24,000	19.7	500	3.02		VS	
CX-32	2	2.95	75.0	6,000	24,000	23.6	600	5.00		C	

* C32 is a two-piece external skive only coupling.

QC Four Spiral Hose (Half Bend)

Meets or exceeds the requirements of SAE 100R12 - EN856
(Half the bend radius of SAE100R12)



- Tube: Seamless, black, oil and heat resistant synthetic rubber
- Reinforcement: Four spirals of high tensile wire
- Cover: Black, oil, abrasion and weather resistant synthetic rubber, MSHA approved
- Temperature: -40°C to +121°C (-40°F to +250°F)
- Packaging: Coils
- Application: Hydraulic systems with petroleum or water/glycol based fluids and for fuel and lubricating oils.

PART NUMBER	HOSE I.D.		HOSE O.D.		MAXIMUM WORKING PRESSURE (psi)	MINIMUM BURST PRESSURE (psi)	MINIMUM BEND RADIUS		WEIGHT (lbs/ft)	ONE PIECE Non-Skive	ONE PIECE Skive
	(in)	(in)	(mm)	(mm)			(in)	(mm)		COUPLINGS	COUPLINGS
QC-06	3/8	0.80	20	4,000	16,000	2.5	64	.40	N, V		
QC-08	1/2	0.94	24	4,000	16,000	3.5	89	.54	N, V		
QC-10	5/8	1.08	27	4,000	16,000	4.0	102	.74	N		
QC-12	3/4	1.21	31	4,000	16,000	4.8	121	.94	N, V		
QC-16	1	1.50	38	4,000	16,000	6.0	153	1.34	N, V		
QC-20	1 1/4	1.85	47	3,000	12,000	8.3	210	1.74	N	VS	
QC-24	1 1/2	2.10	53	2,500	10,000	10.0	254	2.01	N	VS	
QC-32	2	2.63	67	2,500	10,000	12.5	318	2.75	N	VS	

* Hose can also be used with OEM reuseable couplings.

VC Six Spiral Wire Hose (Half Bend)

Meets or exceeds the requirements of SAE 100R13
(Half the bend radius of SAE100R13)



- Tube: Seamless, black, oil and heat resistant synthetic rubber
- Reinforcement: 3/4 & 1" 4 spirals, 1 1/4 thru 2" 6 spirals of high tensile steel
- Cover: Black, oil, abrasion and weather resistant synthetic rubber, MSHA approved
- Temperature: -40°C to +121°C (-40°F to +250°F)
- Packaging: Coils
- Application: Hydraulic systems with petroleum or water/glycol based fluids and for fuel and lubricating oils.

PART NUMBER	HOSE I.D.		HOSE O.D.		MAXIMUM WORKING PRESSURE (psi)	MINIMUM BURST PRESSURE (psi)	MINIMUM BEND RADIUS		WEIGHT (lbs/ft)	ONE PIECE Non-Skive	ONE PIECE Skive
	(in)	(mm)	(in)	(mm)			(in)	(mm)		COUPLINGS	COUPLINGS
VC-12	3/4	19.0	1.26	32.0	5,000	20,000	5.5	141	1.07	V	
VC-16	1	25.4	1.52	39.0	5,000	20,000	6.0	153	1.40	V	
VC-20	1 1/4	31.8	1.96	50.0	5,000	20,000	8.3	210	2.48		VS
VC-24	1 1/2	38.1	2.26	57.0	5,000	20,000	10.0	254	3.22		VS
VC-32	2	50.8	2.80	71.0	5,000	20,000	12.5	318	5.03		VS

* Hose can also be used with OEM reuseable couplings.

CC Six Spiral Wire Hose (Half Bend)

Meets or exceeds the requirements of SAE 100R15
(Half the bend radius of SAE100R15)



- Tube: Black; oil resistant synthetic rubber
- Reinforcement: Six spiral layers of high tensile steel wire
- Cover: Black; oil, water, ozone & flame resistant synthetic rubber
- Temperature: -40°C to +121°C (-40°F to +250°F)
- Packaging: Coils
- Application: Hydraulic systems with petroleum or water/glycol based fluids and for fuel and lubricating oils.

PART NUMBER	HOSE I.D.		HOSE O.D.		MAXIMUM WORKING PRESSURE (psi)	MINIMUM BURST PRESSURE (psi)	MINIMUM BEND RADIUS		WEIGHT (lbs/ft)	ONE PIECE Non-Skive	ONE PIECE Skive
	(in)	(mm)	(in)	(mm)			(in)	(mm)		COUPLINGS	COUPLINGS
CC-06	3/8	9.5	0.69	17.5	6,000	24,000	3.0	76	0.51	V	
CC-08	1/2	12.7	0.80	20.2	6,000	24,000	4.0	102	0.59	V	
CC-12	3/4	19.0	1.13	28.7	6,000	24,000	5.2	133	1.09	V	
CC-16	1	25.4	1.39	35.3	6,000	24,000	6.5	165	1.46	V	
CC-20	1 1/4	31.8	1.77	45.0	6,000	24,000	8.7	222	2.40		VS
CC-24	1 1/2	38.1	2.03	51.6	6,000	24,000	10.5	267	3.02		VS
CC-32	2	50.8	2.73	69.5	6,000	24,000	26.0	660	4.09		VS

* Hose can also be used with OEM reuseable couplings.

COUPLINGS



FLEXTRAL

COUPLINGS

STYLE	SERIES	DESCRIPTION
NPTF - NPSM	MP	NPT MALE
	MPA	NPT MALE (API)
	MPL	NPT MALE LONG
	MP90	NPT MALE - 90° ELBOW
	MPX	NPT MALE SWIVEL
	MPX90B	NPT MALE SWIVEL - 90° BLOCK ELBOW
	FP	NPT FEMALE RIGID
	FPX	NPSM FEMALE SWIVEL (60° CONE SEAT)
	FPXT	FPT FEMALE PIPE SWIVEL (DRY SEAL)
JIC	MJ	JIC 37° MALE
	FJ	JIC 37° FEMALE SWIVEL
	FJ45	JIC 37° FEMALE SWIVEL - 45° ELBOW
	FJ90B	JIC 90° COMPACT FEMALE
	FJ90S	JIC 37° FEMALE SWIVEL - 90° ELBOW SHORT DROP
	FJ90M	JIC 37° FEMALE SWIVEL - 90° ELBOW MEDIUM DROP
	FJ90L	JIC 37° FEMALE SWIVEL - 90° ELBOW LONG DROP
ORFS	MF	ORFS MALE
	FF	ORFS FEMALE SWIVEL
	FF45	ORFS FEMALE SWIVEL - 45° ELBOW
	FF90S	ORFS FEMALE SWIVEL - 90° ELBOW SHORT DROP
	FF90M	ORFS FEMALE SWIVEL - 90° ELBOW MEDIUM DROP
	FF90L	ORFS FEMALE SWIVEL - 90° ELBOW LONG DROP
SAE	MA	SAE 45° MALE
	FA	SAE 45° FEMALE SWIVEL
	FA45	SAE 45° FEMALE SWIVEL - 45° ELBOW
	FA90	SAE 45° FEMALE SWIVEL - 90° ELBOW
	MOB	O-RING BOSS MALE
	MOBX	O-RING BOSS MALE SWIVEL
	MOBX90B	O-RING BOSS MALE SWIVEL - 90° BLOCK ELBOW
	MIX	SAE INVERTED FLARE MALE SWIVEL
	MIX45	SAE INVERTED FLARE MALE SWIVEL - 45° ELBOW
	MIX90	SAE INVERTED FLARE MALE SWIVEL - 90° ELBOW
	FIX	SAE INVERTED FLARE FEMALE RIGID
	MRNS	SAE FLARLESS MALE ASSEMBLY
GREASE	FG	FEMALE GREASE



COUPLINGS

STYLE	SERIES	DESCRIPTION
JIS	FJIS	JIS FEMALE SWIVEL (TOYOTA)
	FJIS90	JIS FEMALE SWIVEL (TOYOTA) - 90° ELBOW
	FK	KOMATSU FEMALE SWIVEL
	FK45	KOMATSU FEMALE SWIVEL - 45° ELBOW
	FK90	KOMATSU FEMALE SWIVEL - 90° ELBOW
	FLK	KOMATSU FLANGE
	FLK45	KOMATSU FLANGE - 45° ELBOW
	FLK90	KOMATSU FLANGE - 90° ELBOW
	MKBC	KOBELCO MALE
BSP	MBSPT	BSPT MALE
	MBSPP	BSPP MALE
	FBSPP	BSPP FEMALE SWIVEL
	FBSPP45	BSPP FEMALE SWIVEL - 45° ELBOW
	FBSPP90	BSPP FEMALE SWIVEL - 90° ELBOW
	FBSPP90B	BSPP FEMALE SWIVEL - 90° ELBOW BLOCK
	FBSPPFF	BSP FLAT FACE FEMALE SWIVEL
	BJBSP	BSP BANJO
	BJBSPBT	BSP BANJO BOLT
METRIC	SPML	METRIC STANDPIPE (LIGHT)
	SPML45	METRIC STANDPIPE (LIGHT) - 45° ELBOW
	SPML90	METRIC STANDPIPE (LIGHT) - 90° ELBOW
	BJM	METRIC BANJO
	BJMBT	METRIC BANJO BOLT
	MML	METRIC LIGHT MALE (24° CONE SEAT) - CEL
	FML	METRIC LIGHT FEMALE SWIVEL (24° CONE SEAT) - DKOL
	FML45	METRIC LIGHT FEMALE SWIVEL - 45° ELBOW (24° CONE SEAT) - DKOL
	FML90	METRIC LIGHT FEMALE SWIVEL - 90° ELBOW (24° CONE SEAT) - DKOL
	MMS	METRIC HEAVY MALE (24° CONE SEAT) - CES
	FMS	METRIC HEAVY FEMALE SWIVEL (24° CONE SEAT) - DKOS
	FMS45	METRIC HEAVY FEMALE SWIVEL - 45° ELBOW (24° CONE SEAT) - DKOS
	FMS90	METRIC HEAVY FEMALE SWIVEL - 90° ELBOW (24° CONE SEAT) - DKOS
	MGAZ	FRENCH GAZ MALE
	FGAZ	FRENCH GAZ FEMALE
SAE CODE 61	FL	SAE CODE 61 FLANGE
	FL22	SAE CODE 61 FLANGE - 22.5° ELBOW
	FL30	SAE CODE 61 FLANGE - 30° ELBOW
	FL45	SAE CODE 61 FLANGE - 45° ELBOW
	FL60	SAE CODE 61 FLANGE - 60° ELBOW
	FL67	SAE CODE 61 FLANGE - 67.5° ELBOW
	FL90	SAE CODE 61 FLANGE - 90° ELBOW
	FL100	SAE CODE 61 FLANGE - 100° ELBOW
	FL110	SAE CODE 61 FLANGE - 110° ELBOW
	FL135	SAE CODE 61 FLANGE - 135° ELBOW
	LET	SAE CODE 61 FLANGE
	LET45	SAE CODE 61 FLANGE - 45° ELBOW
	LET90	SAE CODE 61 CAPTIVE FLANGE 500 PSI - 90° ELBOW

COUPLINGS

STYLE	SERIES	DESCRIPTION
SAE CODE 62	FLH	SAE CODE 62 FLANGE
	FLH22	SAE CODE 62 FLANGE - 22.5° ELBOW
	FLH30	SAE CODE 62 FLANGE - 30° ELBOW
	FLH45	SAE CODE 62 FLANGE - 45° ELBOW
	FLH60	SAE CODE 62 FLANGE - 60° ELBOW
	FLH67	SAE CODE 62 FLANGE - 67.5° ELBOW
	FLH90	SAE CODE 62 FLANGE - 90° ELBOW
CATERPILLAR® FLANGE	FLC	CATERPILLAR® FLANGE
	FLC22	CATERPILLAR® FLANGE - 22.5° ELBOW
	FLC30	CATERPILLAR® FLANGE - 30° ELBOW
	FLC45	CATERPILLAR® FLANGE - 45° ELBOW
	FLC60	CATERPILLAR® FLANGE - 60° ELBOW
	FLC67	CATERPILLAR® FLANGE - 67.5° ELBOW
	FLC90	CATERPILLAR® FLANGE - 90° ELBOW
ULTRA-HIGH PRESSURE CAPTIVE FLANGE	FLOKA	O&K® FLANGE
	FLOKA22	O&K® FLANGE - 22° ELBOW
	FLOKA45	O&K® FLANGE - 45° ELBOW
	FLOKA90	O&K® FLANGE - 90° ELBOW
	OKBR	FLOKA CRIMP STRAIN RELIEF
AIR CONDITIONING	BTF	BUMPED TUBE O-RING FEMALE SWIVEL
	BTF-P	BUMPED TUBE O-RING FEMALE SWIVEL (R134a SERVICE PORT)
	BTF45	BUMPED TUBE O-RING FEMALE SWIVEL - 45° ELBOW
	BTF45-P	BUMPED TUBE O-RING FEMALE SWIVEL - 45° ELBOW (R134a SERVICE PORT)
	BTF90	BUMPED TUBE O-RING FEMALE SWIVEL - 90° ELBOW
	BTF90-P	BUMPED TUBE O-RING FEMALE SWIVEL - 90° ELBOW (R134a SERVICE PORT)
	BTM	BUMPED TUBE O-RING MALE SWIVEL
	BTM45	BUMPED TUBE O-RING MALE SWIVEL - 45° ELBOW
	BTM90	BUMPED TUBE O-RING MALE SWIVEL - 90° ELBOW
	BTM90-P	BUMPED TUBE O-RING MALE SWIVEL - 90° ELBOW (R134a SERVICE PORT)
	IOM	INSERT O-RING MALE
	IOM90	INSERT O-RING MALE - 90° ELBOW
	HM-P	HOSE MENDER (R134a SERVICE PORT)
	BS	BRAZE SOCKET
	ACF	AIR CONDITIONING FERRULE
ACO	AIR CONDITIONING O-RINGS	
PRESSURE WASH	MPWK	PRESSURE WASH GUN END
	FPWK	PRESSURE WASH FEMALE SWIVEL TYPE - K
	FPWS	PRESSURE WASH (SW5)
	FPWW	PRESSURE WASH FEMALE SWIVEL TYPE - W
OTHER	HM	HOSE MENDER
	SP	IMPERIAL STANDPIPE

COUPLINGS

MP

NPT MALE

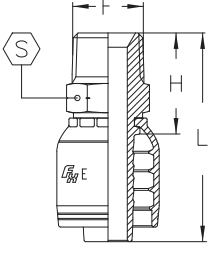

PART NUMBER	Hose Bore	F	H		L		S	
	INCH		[mm]	[in]	[mm]	[in]	[mm]	[in]
E03-02MP	3/16	1/8 - 27	20.6	0.81	45.6	1.79	12	1/2
E03-04MP	3/16	1/4 - 18	26.5	1.04	51.5	2.03	14	9/16
E04-02MP	1/4	1/8 - 27	21.1	0.83	49.1	1.93	12	1/2
E04-04MP	1/4	1/4 - 18	27.0	1.06	55.0	2.16	14	9/16
E04-06MP	1/4	3/8 - 18	28.6	1.12	56.6	2.23	19	3/4
E04-08MP	1/4	1/2 - 14	34.0	1.34	62.0	2.44	22	7/8
E05-04MP	5/16	1/4 - 18	27.0	1.06	55.0	2.16	14	9/16
E05-06MP	5/16	3/8 - 18	28.6	1.12	56.6	2.23	19	3/4
E06-04MP	3/8	1/4 - 18	27.5	1.08	58.0	2.28	16	5/8
E06-06MP	3/8	3/8 - 18	28.6	1.12	59.1	2.33	19	3/4
E06-08MP	3/8	1/2 - 14	34.0	1.34	64.5	2.54	22	7/8
E08-04MP	1/2	1/4 - 18	30.5	1.20	63.2	2.49	22	7/8
E08-06MP	1/2	3/8 - 18	30.6	1.20	63.6	2.50	22	7/8
E08-08MP	1/2	1/2 - 14	35.0	1.38	68.0	2.68	22	7/8
E08-12MP	1/2	3/4 - 14	36.9	1.45	69.9	2.75	27	1 1/16
E10-08MP	5/8	1/2 - 14	36.2	1.42	72.0	2.83	25	1
E10-12MP	5/8	3/4 - 14	37.1	1.46	72.9	2.87	27	1 1/16
E12-08MP	3/4	1/2 - 14	37.5	1.48	78.0	3.07	27	1 1/16
E12-12MP	3/4	3/4 - 14	37.9	1.49	78.4	3.09	27	1 1/16
E12-16MP	3/4	1 - 11 1/2	45.5	1.79	86.0	3.38	35	1 7/16
E16-12MP	1	3/4 - 14	40.4	1.59	91.4	3.60	32	1 1/4
E16-16MP	1	1 - 11 1/2	47.0	1.85	98.0	3.86	35	1 7/16
E16-20MP	1	1 1/4 - 11 1/2	51.1	2.01	102.1	4.02	46	1 13/16
E20-20MP	1 1/4	1 1/4 - 11 1/2	51.9	2.04	109.6	4.31	46	1 13/16
E24-24MP	1 1/2	1 1/2 - 11 1/2	55.0	2.16	119.5	4.70	50	2
E32-32MP	2	2 - 11 1/2	64.0	2.52	134.0	5.27	65	2 9/16

MPL

NPT MALE LONG

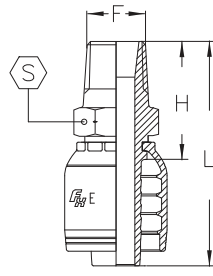

PART NUMBER	Hose Bore	F	H		L		S	
	INCH		[mm]	[in]	[mm]	[in]	[mm]	[in]
E04-04MPL	1/4	1/4 - 18	36.8	1.45	64.8	2.55	14	9/16
E04-06MPL	1/4	3/8 - 18	38.9	1.53	66.9	2.63	19	3/4
E06-04MPL	3/8	1/4 - 18	36.8	1.45	67.3	2.55	16	5/8
E06-06MPL	3/8	3/8 - 18	38.9	1.53	69.4	2.73	19	3/4

Reference Hose Section for Coupling Compatibility

COUPLINGS

MPX NPT MALE SWIVEL

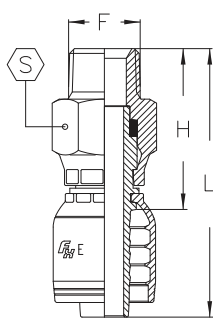

PART NUMBER	Hose Bore	F	H		L		S	
	INCH		[mm]	[in]	[mm]	[in]	[mm]	[in]
E04-04MPX	1/4	1/4 - 18	41	1.61	69	2.72	17	11/16
E04-06MPX	1/4	3/8 - 18	46	1.81	74	2.91	22	7/8
E06-04MPX	3/8	1/4 - 18	41	1.61	72	2.83	17	11/16
E06-06MPX	3/8	3/8 - 18	45	1.77	75	2.95	22	7/8
E06-08MPX	3/8	1/2 - 14	57	2.24	88	3.46	27	11/16
E08-06MPX	1/2	3/8 - 18	46	1.81	79	3.11	22	7/8
E08-08MPX	1/2	1/2 - 14	56	2.20	89	3.50	27	11/16
E12-08MPX	3/4	1/2 - 14	57	2.24	98	3.86	27	11/16
E12-12MPX	3/4	3/4 - 14	61	2.40	101	3.98	34	13/8
E16-16MPX	1	1 - 11 1/2	65	2.56	116	4.57	38	1 1/2

MPX90B NPT MALE SWIVEL - 90° BLOCK ELBOW

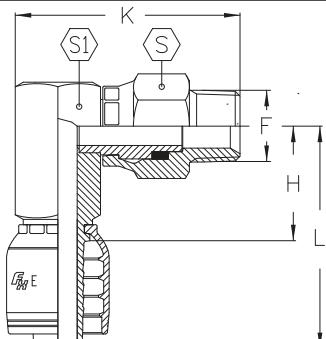

PART NUMBER	Hose Bore	F	H		L		K		S	
	INCH		[mm]	[in]	[mm]	[in]	[mm]	[in]	[mm]	[in]
E04-04MPX90B	1/4	1/4 - 18	32.0	1.26	60.0	2.36	39.7	1.56	16	5/8
E06-06MPX90B	3/8	3/8 - 18	32.5	1.28	63.0	2.48	41.0	1.61	19	3/4
E08-08MPX90B	1/2	1/2 - 14	33.0	1.30	66.0	2.60	48.0	1.89	22	7/8
E12-12MPX90B	3/4	3/4 - 14	43.5	1.71	84.0	3.31	64.0	2.52	32	1 1/4

FP NPT FEMALE RIGID

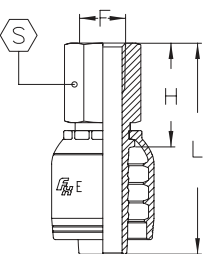

PART NUMBER	Hose Bore	F	H		L		S	
	INCH		[mm]	[in]	[mm]	[in]	[mm]	[in]
E04-02FP	1/4	1/8 - 27	21.5	0.85	49.5	1.95	16	5/8
E04-04FP	1/4	1/4 - 18	27.1	1.07	55.1	2.17	19	3/4
E04-06FP	1/4	3/8 - 18	28.4	1.12	56.4	2.22	22	7/8
E06-04FP	3/8	1/4 - 18	27.1	1.07	57.6	2.27	19	3/4
E06-06FP	3/8	3/8 - 18	28.4	1.12	58.9	2.32	22	7/8
E06-08FP	3/8	1/2 - 14	34.5	1.36	65.0	2.56	29	13/16
E08-08FP	1/2	1/2 - 14	35.5	1.40	68.5	2.70	29	13/16
E12-12FP	3/4	3/4 - 14	38.0	1.50	78.5	3.09	32	1 1/4

Reference Hose Section for Coupling Compatibility

COUPLINGS

FPX

NPSM FEMALE SWIVEL (60° CONE SEAT)

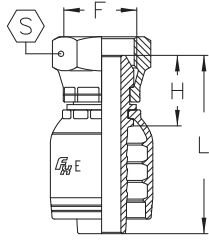

PART NUMBER	Hose Bore	F	H		L		S	
	INCH		[mm]	[in]	[mm]	[in]	[mm]	[in]
E04-04FPX	1/4	1/4 - 18	19	0.75	47	1.85	17	11/16
E06-06FPX	3/8	3/8 - 18	21	0.83	51	2.00	22	7/8
E08-08FPX	1/2	1/2 - 14	23	0.90	56	2.20	25	1
E12-12FPX	3/4	3/4 - 14	27	1.06	67	2.64	32	1 1/4
E16-16FPX	1	1 - 11 1/2	30	1.18	81	3.19	38	1 1/2

MJ

JIC 37° MALE

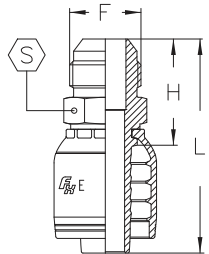

PART NUMBER	Hose Bore	F	H		L		S	
	INCH		[mm]	[in]	[mm]	[in]	[mm]	[in]
E03-04MJ	3/16	7/16 - 20	25.0	0.98	50.0	1.97	12	1/2
E04-04MJ	1/4	7/16 - 20	25.5	1.00	53.5	2.11	12	1/2
E04-05MJ	1/4	1/2 - 20	25.5	1.00	53.5	2.11	14	9/16
E04-06MJ	1/4	9/16 - 18	26.6	1.05	54.6	2.15	15	5/8
E05-05MJ	5/16	1/2 - 20	25.5	1.00	53.5	2.11	14	9/16
E05-06MJ	5/16	9/16 - 18	26.6	1.05	54.6	2.15	15	5/8
E06-06MJ	3/8	9/16 - 18	26.6	1.05	57.1	2.25	15	5/8
E06-08MJ	3/8	3/4 - 16	29.7	1.17	60.2	2.37	19	3/4
E06-10MJ	3/8	7/8 - 14	34.3	1.35	64.8	2.55	24	1
E08-06MJ	1/2	9/16 - 18	29.7	1.17	62.6	2.46	19	3/4
E08-08MJ	1/2	3/4 - 16	30.7	1.21	63.7	2.51	19	3/4
E08-10MJ	1/2	7/8 - 14	35.3	1.39	68.3	2.69	24	1
E08-12MJ	1/2	1 1/16 - 12	38.9	1.53	71.9	2.83	27	1 1/16
E10-08MJ	5/8	3/4 - 16	33.7	1.33	68.4	2.69	24	1
E10-10MJ	5/8	7/8 - 14	35.5	1.40	71.3	2.81	24	1
E10-12MJ	5/8	1 1/16 - 12	39.1	1.54	74.9	2.95	27	1 1/16
E12-10MJ	3/4	7/8 - 14	37.3	1.47	77.8	3.06	27	1 1/16
E12-12MJ	3/4	1 1/16 - 12	39.9	1.57	80.4	3.16	27	1 1/16
E12-14MJ	3/4	1 3/16 - 12	41.6	1.64	82.1	3.23	32	1 1/4
E12-16MJ	3/4	1 5/16 - 12	42.1	1.66	82.6	3.25	34	1 3/8
E16-16MJ	1	1 5/16 - 12	43.6	1.72	94.6	3.72	34	1 3/8
E16-20MJ	1	1 5/8 - 12	46.8	1.84	97.8	3.85	42	1 11/16
E20-20MJ	1 1/4	1 5/8 - 12	47.6	1.87	105.3	4.14	42	1 11/16

Reference Hose Section for Coupling Compatibility

COUPLINGS

FJ JIC 37° FEMALE SWIVEL

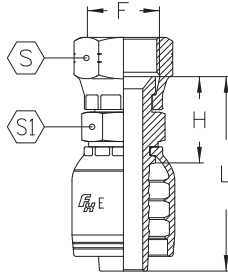

PART NUMBER	Hose Bore	F	H		L		S		S1	
	INCH		[mm]	[in]	[mm]	[in]	[mm]	[in]	[mm]	[in]
E03-04FJ	3/16	7/16 - 20	19.0	0.75	44.0	1.73	14	9/16	12	1/2
E04-04FJ	1/4	7/16 - 20	20.5	0.81	48.5	1.91	14	9/16	14	9/16
E04-05FJ	1/4	1/2 - 20	21.0	0.83	49.0	1.93	17	11/16	14	9/16
E04-06FJ	1/4	9/16 - 18	22.0	0.87	50.0	1.97	19	3/4	14	9/16
E05-05FJ	5/16	1/2 - 20	21.0	0.83	49.0	1.93	17	11/16	14	9/16
E05-06FJ	5/16	9/16 - 18	22.5	0.88	50.5	1.99	19	3/4	16	5/8
E06-04FJ	3/8	7/16 - 20	21.0	0.83	51.5	2.03	14	9/16	16	5/8
E06-05FJ	3/8	1/2 - 20	21.5	0.85	52.0	2.05	17	11/16	16	5/8
E06-06FJ	3/8	9/16 - 18	22.5	0.88	53.0	2.09	19	3/4	16	5/8
E06-08FJ	3/8	3/4 - 16	24.5	0.96	55.0	2.16	22	7/8	19	3/4
E06-10FJ	3/8	7/8 - 14	36.5	1.44	57.0	2.24	27	11/16	22	7/8
E08-06FJ	1/2	9/16 - 18	24.5	0.96	57.5	2.26	19	3/4	19	3/4
E08-08FJ	1/2	3/4 - 16	25.5	1.00	58.5	2.30	22	7/8	19	3/4
E08-10FJ	1/2	7/8 - 14	27.5	1.08	60.5	2.38	27	11/16	22	7/8
E08-12FJ	1/2	11/16 - 12	30.3	1.19	63.3	2.49	32	1 1/4	25	1
E10-08FJ	5/8	3/4 - 16	26.7	1.05	62.5	2.46	22	7/8	22	7/8
E10-10FJ	5/8	7/8 - 14	27.7	1.09	63.5	2.50	27	11/16	22	7/8
E10-12FJ	5/8	11/16 - 12	30.5	1.20	66.3	2.61	32	1 1/4	25	1
E12-10FJ	3/4	7/8 - 14	30.0	1.18	70.5	2.77	27	11/16	27	1 1/16
E12-12FJ	3/4	11/16 - 12	31.8	1.25	72.3	2.85	32	1 1/4	27	1 1/16
E12-14FJ	3/4	1 3/16 - 12	34.5	1.36	75.0	2.95	36	1 7/16	30	1 3/16
E12-16FJ	3/4	1 5/16 - 12	35.5	1.40	76.0	2.99	38	1 1/2	32	1 1/4
E16-12FJ	1	11/16 - 12	34.3	1.35	85.3	3.36	32	1 1/4	32	1 1/4
E16-16FJ	1	1 5/16 - 12	37.0	1.46	88.0	3.46	38	1 1/2	32	1 1/4
E16-20FJ	1	1 5/8 - 12	42.0	1.65	93.0	3.66	50	2	41	1 5/8
E20-20FJ	1 1/4	1 5/8 - 12	42.8	1.68	100.5	3.96	50	2	41	1 5/8
E24-24FJ	1 1/2	1 7/8 - 12	47.0	1.85	111.5	4.39	60	2 1/2	46	1 3/16
E32-32FJ	2	2 1/2 - 12	55.5	2.18	125.5	4.94	75	3	60	2 1/2

Reference Hose Section for Coupling Compatibility

COUPLINGS

FJ45

JIC 37° FEMALE SWIVEL - 45° ELBOW

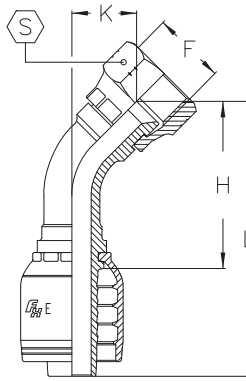

PART NUMBER	Hose Bore	F	H		L		K		S	
	INCH		[mm]	[in]	[mm]	[in]	[mm]	[in]	[mm]	[in]
E03-04FJ45	3/16	7/16 - 20	29.0	1.14	54	2.12	10	0.39	14	9/16
E04-04FJ45	1/4	7/16 - 20	31.0	1.22	59	2.32	10	0.39	14	9/16
E04-05FJ45	1/4	1/2 - 20	32.0	1.26	60	2.36	11	0.43	17	11/16
E04-06FJ45	1/4	9/16 - 18	33.0	1.30	61	2.40	12	0.47	19	3/4
E05-05FJ45	5/16	1/2 - 20	33.0	1.30	61	2.40	11	0.43	17	11/16
E05-06FJ45	5/16	9/16 - 18	34.0	1.34	62	2.44	12	0.47	19	3/4
E06-06FJ45	3/8	9/16 - 18	35.5	1.40	66	2.60	12	0.47	19	3/4
E06-08FJ45	3/8	3/4 - 16	37.5	1.48	68	2.68	14	0.55	22	7/8
E08-08FJ45	1/2	3/4 - 16	41.0	1.61	74	2.91	14	0.57	22	7/8
E08-10FJ45	1/2	7/8 - 14	43.0	1.69	76	2.99	16	0.63	27	11/16
E08-12FJ45	1/2	1 1/16 - 12	45.5	1.79	79	3.09	19	0.75	32	1 1/4
E10-10FJ45	5/8	7/8 - 14	47.0	1.85	83	3.27	16	0.63	27	1 1/16
E10-12FJ45	5/8	1 1/16 - 12	50.0	1.97	86	3.38	19	0.75	32	1 1/4
E12-12FJ45	3/4	1 1/16 - 12	57.0	2.24	97	3.82	20	0.79	32	1 1/4
E12-14FJ45	3/4	1 3/16 - 12	59.0	2.32	100	3.94	22	0.87	36	1 7/16
E12-16FJ45	3/4	1 5/16 - 12	61.0	2.40	101	3.98	24	0.94	38	1 1/2
E16-16FJ45	1	1 5/16 - 12	72.0	2.83	123	4.84	24	0.94	38	1 1/2
E16-20FJ45	1	1 5/8 - 12	76.0	2.99	127	5.00	28	1.10	50	2
E20-20FJ45	1 1/4	1 5/8 - 12	85.0	3.35	143	5.63	38	1.10	50	2
E24-24FJ45	1 1/2	1 7/8 - 12	99.0	3.90	164	6.46	46	1.26	60	2 3/8
E32-32FJ45	2	2 1/2 - 12	132.0	5.20	202	7.95	61	1.69	70	2 3/4

Reference Hose Section for Coupling Compatibility

COUPLINGS

FJ90B JIC 90° COMPACT FEMALE

PART NUMBER	Hose Bore	F	H		L		K		S	
	INCH		[mm]	[in]	[mm]	[in]	[mm]	[in]	[mm]	[in]
E04-04FJ90B	1/4	7/16 - 20	17.3	0.68	43.6	1.72	18.8	0.74	14	9/16
E04-06FJ90B	1/4	9/16 - 18	17.3	0.68	44.2	1.74	21.6	0.85	19	3/4
E06-06FJ90B	3/8	9/16 - 18	17.8	0.68	52.1	2.05	21.6	0.85	19	3/4
E06-08FJ90B	3/8	3/4 - 16	20.9	0.82	52.0	2.04	26.2	1.03	22	7/8
E08-08FJ90B	1/2	3/4 - 16	21.2	0.83	52.0	2.04	26.2	1.03	22	7/8

FJ90S JIC 37° FEMALE SWIVEL - 90° ELBOW SHORT DROP

PART NUMBER	Hose Bore	F	H		L		K		S	
	INCH		[mm]	[in]	[mm]	[in]	[mm]	[in]	[mm]	[in]
E03-04FJ90S	3/16	7/16 - 20	21.0	0.83	46.0	1.81	18	0.71	14	9/16
E04-04FJ90S	1/4	7/16 - 20	25.5	1.00	53.5	2.11	20	0.79	14	9/16
E04-05FJ90S	1/4	1/2 - 20	25.5	1.00	53.5	2.11	21	0.83	17	11/16
E04-06FJ90S	1/4	9/16 - 18	25.5	1.00	53.5	2.11	23	0.90	19	3/4
E05-05FJ90S	5/16	1/2 - 20	28.0	1.10	56.0	2.20	22	0.87	17	11/16
E05-06FJ90S	5/16	9/16 - 18	28.0	1.10	56.0	2.20	24	0.94	19	3/4
E06-06FJ90S	3/8	9/16 - 18	30.0	1.18	60.5	2.38	23	0.90	19	3/4
E06-08FJ90S	3/8	3/4 - 16	31.0	1.22	61.5	2.42	29	1.14	22	7/8
E08-08FJ90S	1/2	3/4 - 16	37.0	1.46	70.0	2.75	29	1.14	22	7/8
E08-10FJ90S	1/2	7/8 - 14	38.0	1.50	71.0	2.79	33	1.30	27	1 1/16
E08-12FJ90S	1/2	1 1/16 - 12	40.0	1.57	73.0	2.87	40	1.57	32	1 1/4
E10-10FJ90S	5/8	7/8 - 14	43.0	1.69	79.0	3.11	32	1.26	27	1 1/16
E10-12FJ90S	5/8	1 1/16 - 12	45.0	1.77	81.0	3.19	40	1.57	32	1 1/4
E12-12FJ90S	3/4	1 1/16 - 12	55.0	2.16	95.0	3.74	43	1.69	32	1 1/4
E12-14FJ90S	3/4	1 3/16 - 12	55.0	2.16	95.0	3.74	47	1.85	36	1 7/16
E12-16FJ90S	3/4	1 5/16 - 12	55.0	2.16	95.0	3.74	49	1.93	38	1 1/2
E16-16FJ90S	1	1 5/16 - 12	71.0	2.79	122.0	4.80	56	2.20	38	1 1/2
E16-20FJ90S	1	1 5/8 - 12	71.0	2.79	122.0	4.80	61	2.40	50	2
E20-20FJ90S	1 1/4	1 5/8 - 12	86.0	3.38	143.0	5.63	65	2.56	50	2
E24-24FJ90S	1 1/2	1 7/8 - 12	102.0	4.01	167.0	6.57	76	2.99	60	2 3/8
E32-32FJ90S	2	2 1/2 - 12	137.0	5.39	207.0	8.15	104	4.09	70	2 3/4

Reference Hose Section for Coupling Compatibility

COUPLINGS

FJ90M

JIC 37° FEMALE SWIVEL - 90° ELBOW MEDIUM DROP

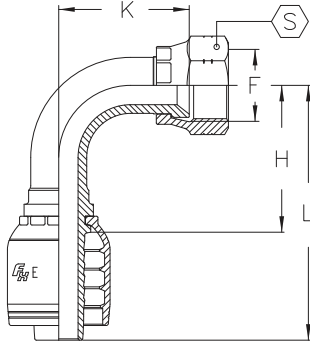

PART NUMBER	Hose Bore	F	H		L		K		S	
	INCH		[mm]	[in]	[mm]	[in]	[mm]	[in]	[mm]	[in]
E03-04FJ90M	3/16	7/16 - 20	21.0	0.83	46.0	1.81	21	0.83	14	9/16
E04-04FJ90M	1/4	7/16 - 20	25.5	1.00	53.5	2.11	26	1.02	14	9/16
E04-05FJ90M	1/4	1/2 - 20	25.5	1.00	53.5	2.11	26	1.02	17	11/16
E04-06FJ90M	1/4	9/16 - 18	25.5	1.00	53.5	2.11	27	1.06	19	3/4
E05-05FJ90M	5/16	1/2 - 20	28.0	1.10	56.0	2.20	29	1.14	17	11/16
E05-06FJ90M	5/16	9/16 - 18	28.0	1.10	56.0	2.20	29	1.14	19	3/4
E06-06FJ90M	3/8	9/16 - 18	31.0	1.22	61.5	2.42	33	1.30	19	3/4
E06-08FJ90M	3/8	3/4 - 16	31.0	1.22	61.5	2.42	33	1.30	22	7/8
E08-08FJ90M	1/2	3/4 - 16	37.0	1.46	70.0	2.75	39	1.53	22	7/8
E08-10FJ90M	1/2	7/8 - 14	37.0	1.46	70.0	2.75	40	1.57	27	11/16
E10-10FJ90M	5/8	7/8 - 14	45.0	1.77	81.0	3.19	45	1.77	27	11/16
E10-12FJ90M	5/8	1 1/16 - 12	45.0	1.77	81.0	3.19	47	1.85	32	1 1/4
E12-10FJ90M	3/4	7/8 - 14	55.0	2.16	95.0	3.74	54	2.12	27	1 1/16
E12-12FJ90M	3/4	1 1/16 - 12	55.0	2.16	95.0	3.74	53	2.09	32	1 1/4
E12-14FJ90M	3/4	1 3/16 - 12	55.0	2.16	95.0	3.74	54	2.12	36	1 7/16
E12-16FJ90M	3/4	1 5/16 - 12	55.0	2.16	95.0	3.74	56	2.20	38	1 1/2
E16-12FJ90M	1	1 1/16 - 12	71.0	2.79	122.0	4.80	71	2.79	32	1 1/4
E16-16FJ90M	1	1 5/16 - 12	71.0	2.79	122.0	4.80	70	2.75	38	1 1/2
E16-20FJ90M	1	1 5/8 - 12	71.0	2.79	122.0	4.80	70	2.75	50	2
E20-20FJ90M	1 1/4	1 5/8 - 12	86.0	3.38	143.0	5.63	82	3.23	50	2
E20-24FJ90M	1 1/4	1 7/8 - 12	86.0	3.38	143.0	5.63	82	3.23	60	2 3/8
E24-24FJ90M	1 1/2	1 7/8 - 12	102.0	4.01	167.0	6.57	96	3.78	60	2 3/8
E32-32FJ90M	2	2 1/2 - 12	137.0	5.39	207.0	8.15	134	5.27	70	2 3/4

Reference Hose Section for Coupling Compatibility

COUPLINGS

FJ90L JIC 37° FEMALE SWIVEL - 90° ELBOW LONG DROP

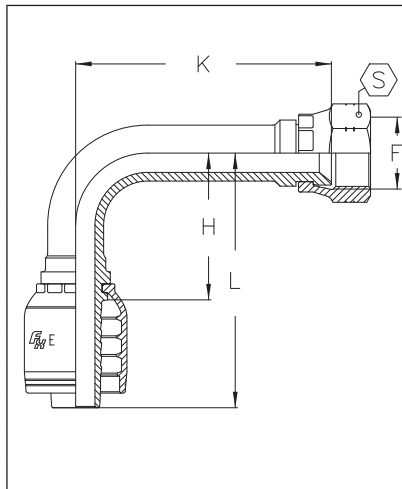

PART NUMBER	Hose Bore	F	H		L		K		S	
	INCH		[mm]	[in]	[mm]	[in]	[mm]	[in]	[mm]	[in]
E04-04FJ90L	1/4	7/16 - 20	25.5	1.00	53.5	2.11	46	1.81	14	9/16
E04-05FJ90L	1/4	1/2 - 20	25.5	1.00	53.5	2.11	46	1.81	17	11/16
E04-06FJ90L	1/4	9/16 - 18	25.5	1.00	53.5	2.11	54	2.12	19	3/4
E06-06FJ90L	3/8	9/16 - 18	31.0	1.22	61.5	2.42	54	2.12	19	3/4
E06-08FJ90L	3/8	3/4 - 16	31.0	1.22	61.5	2.42	64	2.52	22	7/8
E08-08FJ90L	1/2	3/4 - 16	38.0	1.50	71.0	2.79	64	2.52	22	7/8
E08-10FJ90L	1/2	7/8 - 14	38.0	1.50	71.0	2.79	70	2.75	27	1 1/16
E10-10FJ90L	5/8	7/8 - 14	45.0	1.77	81.0	3.19	70	2.75	27	1 1/16
E10-12FJ90L	5/8	1 1/16 - 12	45.0	1.77	81.0	3.19	96	3.78	32	1 1/4
E12-12FJ90L	3/4	1 1/16 - 12	55.0	2.16	95.0	3.74	96	3.78	32	1 1/4
E16-16FJ90L	1	1 5/16 - 12	71.0	2.79	122.0	4.80	114	4.49	38	1 1/2
E20-20FJ90L	1 1/4	1 5/8 - 12	86.0	3.39	143.0	5.63	129	5.08	50	2

MF ORFS MALE

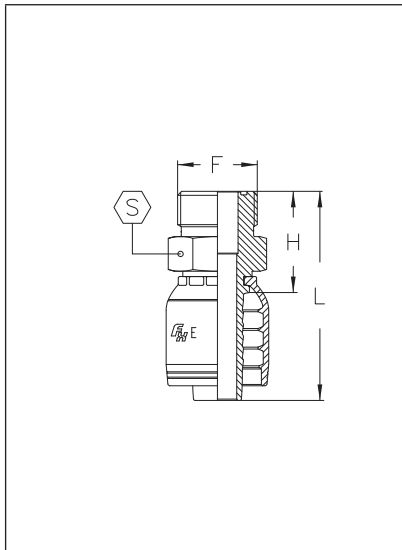

PART NUMBER	Hose Bore	F	H		L		S	
	INCH		[mm]	[in]	[mm]	[in]	[mm]	[in]
E04-04MF	1/4	9/16 - 18	23.5	0.92	51.5	2.02	17	11/16
E04-06MF	1/4	1 1/16 - 16	25.5	1.00	53.5	2.10	19	3/4
E06-06MF	3/8	1 1/16 - 16	25.5	1.00	56.0	2.20	19	3/4
E06-08MF	3/8	1 3/16 - 16	28.5	1.12	59.0	2.32	22	7/8
E06-10MF	3/8	1 - 14	33.0	1.29	63.5	2.50	27	1 1/16
E08-08MF	1/2	1 3/16 - 16	29.5	1.16	62.5	2.46	22	7/8
E08-10MF	1/2	1 - 14	34.0	1.33	67.0	2.63	27	1 1/16
E08-12MF	1/2	1 3/16 - 12	37.0	1.45	70.0	2.75	32	1 1/4
E10-10MF	5/8	1 - 14	34.0	1.33	70.0	2.75	27	1 1/16
E10-12MF	5/8	1 3/16 - 12	37.0	1.45	73.0	2.87	32	1 1/4
E12-12MF	3/4	1 3/16 - 12	38.0	1.49	78.5	3.09	32	1 1/4
E12-16MF	3/4	1 7/16 - 12	42.5	1.67	83.0	3.26	41	1 5/8
E16-16MF	1	1 7/16 - 12	44.0	1.73	95.0	3.74	41	1 5/8
E20-20MF	1 1/4	1 11/16 - 12	46.0	1.81	104.0	4.09	46	1 13/16

Reference Hose Section for Coupling Compatibility

COUPLINGS

FF ORFS FEMALE SWIVEL

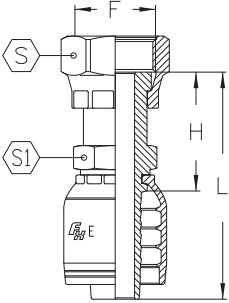

PART NUMBER	Hose Bore	F	H		L		S		S1	
	INCH		[mm]	[in]	[mm]	[in]	[mm]	[in]	[mm]	[in]
E04-04FF	1/4	9/16 - 18	26.5	1.04	54.5	2.14	17	11/16	14	9/16
E04-06FF	1/4	11/16 - 16	28.5	1.12	56.5	2.22	22	7/8	16	5/8
E05-06FF	5/16	11/16 - 16	28.5	1.12	56.5	2.22	22	7/8	16	5/8
E06-04FF	3/8	9/16 - 18	26.5	1.04	57.0	2.24	17	11/16	16	5/8
E06-06FF	3/8	11/16 - 16	28.5	1.12	59.0	2.32	22	7/8	16	5/8
E06-08FF	3/8	13/16 - 16	32.5	1.27	63.0	2.48	24	1	19	3/4
E08-06FF	1/2	11/16 - 16	30.5	1.20	63.5	2.50	22	7/8	19	3/4
E08-08FF	1/2	13/16 - 16	33.5	1.31	66.5	2.61	24	1	19	3/4
E08-10FF	1/2	1 - 14	39.5	1.55	72.5	2.85	30	13/16	24	1
E08-12FF	1/2	13/16 - 12	43.5	1.71	76.5	3.01	36	17/16	27	11/16
E10-10FF	5/8	1 - 14	39.5	1.55	75.5	2.97	30	13/16	24	1
E10-12FF	5/8	13/16 - 12	43.5	1.71	79.5	3.12	36	17/16	27	11/16
E12-10FF	3/4	1 - 14	41.5	1.63	82.0	3.22	30	13/16	27	11/16
E12-12FF	3/4	13/16 - 12	44.5	1.75	85.0	3.34	36	17/16	27	11/16
E12-16FF	3/4	17/16 - 12	47.5	1.87	88.0	3.46	41	15/8	36	17/16
E16-12FF	1	13/16 - 12	47.0	1.85	98.0	3.85	36	17/16	32	1 1/4
E16-16FF	1	17/16 - 12	49.0	1.92	100.0	3.93	41	15/8	36	17/16
E16-20FF	1	1 11/16 - 12	50.5	1.98	102.0	4.01	50	2	41	1 5/8
E20-20FF	1 1/4	1 11/16 - 12	51.0	2.00	109.0	4.29	50	2	41	1 5/8
E24-24FF	1 1/2	2 - 12	54.5	2.14	119.0	4.68	60	2 3/8	50	2

FF45 ORFS FEMALE SWIVEL - 45° ELBOW

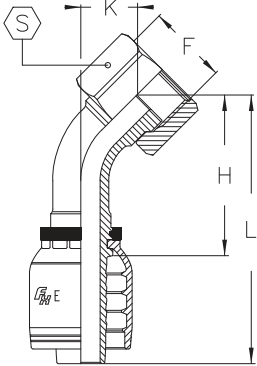

PART NUMBER	Hose Bore	F	H		L		K		S	
	INCH		[mm]	[in]	[mm]	[in]	[mm]	[in]	[mm]	[in]
E04-04FF45	1/4	9/16 - 18	32.5	1.27	60.5	2.38	10.5	0.41	17	11/16
E04-06FF45	1/4	11/16 - 16	34.5	1.35	62.5	2.46	12.5	0.49	22	7/8
E05-06FF45	5/16	11/16 - 16	35.0	1.37	63.0	2.48	12.5	0.49	22	7/8
E06-06FF45	3/8	11/16 - 16	36.0	1.41	66.5	2.61	12.5	0.49	22	7/8
E06-08FF45	3/8	13/16 - 16	38.5	1.51	69.0	2.71	15.0	0.59	24	1
E08-06FF45	1/2	11/16 - 16	46.5	1.83	79.5	3.12	19.5	0.76	22	7/8
E08-08FF45	1/2	13/16 - 16	42.5	1.67	75.5	2.97	15.5	0.61	24	1
E08-10FF45	1/2	1 - 14	45.0	1.77	78.0	3.07	17.5	0.68	30	13/16
E08-12FF45	1/2	13/16 - 12	47.0	1.85	80.0	3.14	20.5	0.80	36	17/16
E10-10FF45	5/8	1 - 14	49.0	1.92	85.0	3.34	18.0	0.70	30	13/16
E10-12FF45	5/8	13/16 - 12	51.5	2.02	87.5	3.44	20.5	0.80	36	17/16
E12-10FF45	3/4	1 - 14	64.0	2.51	104.0	4.09	25.5	1.00	30	13/16
E12-12FF45	3/4	13/16 - 12	58.0	2.28	99.0	3.89	21.0	0.82	36	17/16
E12-16FF45	3/4	17/16 - 12	60.5	2.38	101.0	3.97	23.5	0.92	41	1 5/8
E16-16FF45	1	17/16 - 12	73.0	2.87	124.0	4.88	24.0	0.94	41	1 5/8
E20-20FF45	1 1/4	1 11/16 - 12	84.0	3.30	142.0	5.59	27.0	1.06	50	2
E24-24FF45	1 1/2	2 - 12	98.0	3.85	163.0	6.41	30.0	1.18	60	2 3/8

Reference Hose Section for Coupling Compatibility

COUPLINGS

FF90S ORFS FEMALE SWIVEL - 90° ELBOW SHORT DROP

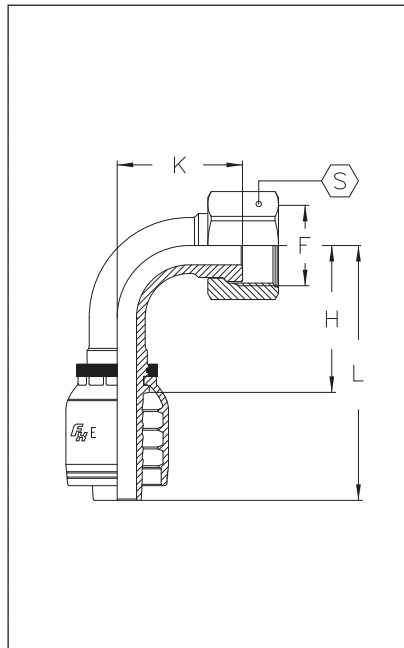

PART NUMBER	Hose Bore	F	H		L		K		S	
	INCH		[mm]	[in]	[mm]	[in]	[mm]	[in]	[mm]	[in]
E04-04FF90S	1/4	9/16 - 18	27.0	1.06	55.0	2.17	21.0	0.83	17	11/16
E04-06FF90S	1/4	11/16 - 16	27.0	1.06	55.0	2.17	24.0	0.94	22	7/8
E05-06FF90S	5/16	11/16 - 16	29.0	1.14	57.0	2.24	25.0	0.98	22	7/8
E06-04FF90S	3/8	9/16 - 18	30.0	1.18	60.5	2.38	22.0	0.87	17	11/16
E06-06FF90S	3/8	11/16 - 16	31.5	1.24	62.0	2.44	24.5	0.96	22	7/8
E06-08FF90S	3/8	13/16 - 16	31.0	1.22	61.0	2.40	30.0	1.18	24	1
E08-08FF90S	1/2	13/16 - 16	39.0	1.54	72.0	2.83	31.0	1.22	24	1
E08-10FF90S	1/2	1 - 14	39.0	1.54	72.0	2.83	34.0	1.34	30	13/16
E08-12FF90S	1/2	13/16 - 12	39.0	1.54	72.0	2.83	42.0	1.65	36	17/16
E10-10FF90S	5/8	1 - 14	45.0	1.77	81.0	3.19	35.0	1.38	30	13/16
E10-12FF90S	5/8	13/16 - 12	45.0	1.77	81.0	3.19	42.0	1.65	36	17/16
E12-12FF90S	3/4	13/16 - 12	55.0	2.17	95.0	3.74	45.0	1.77	36	17/16
E12-16FF90S	3/4	17/16 - 12	55.0	2.17	95.0	3.74	49.0	1.93	41	15/8
E16-16FF90S	1	17/16 - 12	71.0	2.79	122.0	4.80	55.0	2.17	41	15/8
E16-20FF90S	1	111/16 - 12	71.0	2.79	122.0	4.80	58.0	2.28	50	2
E20-20FF90S	1 1/4	111/16 - 12	86.0	3.39	143.0	5.63	63.0	2.48	50	2
E24-24FF90S	1 1/2	2 - 12	102.0	4.02	167.0	6.57	73.0	2.87	60	2 3/8

FF90L ORFS FEMALE SWIVEL - 90° ELBOW LONG DROP

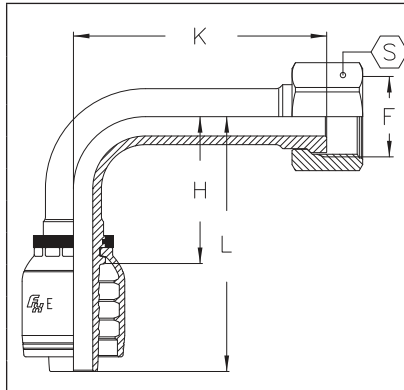

PART NUMBER	Hose Bore	F	H		L		K		S	
	INCH		[mm]	[in]	[mm]	[in]	[mm]	[in]	[mm]	[in]
E04-04FF90L	1/4	9/16 - 18	29.0	1.14	57.0	2.24	46	1.81	17	11/16
E04-06FF90L	1/4	11/16 - 16	27.0	1.06	55.0	2.16	54	2.12	22	7/8
E06-06FF90L	3/8	11/16 - 16	34.0	1.33	64.5	2.53	54	2.12	22	7/8
E06-08FF90L	3/8	13/16 - 16	34.0	1.33	64.5	2.53	64	2.51	24	1
E08-08FF90L	1/2	13/16 - 16	39.0	1.53	72.0	2.83	64	2.51	24	1
E08-10FF90L	1/2	1 - 14	39.0	1.53	72.0	2.83	70	2.75	30	13/16
E10-10FF90L	5/8	1 - 14	45.0	1.77	81.0	3.18	70	2.75	30	13/16
E12-12FF90L	3/4	13/16 - 12	54.0	2.12	95.0	3.74	96	3.77	36	17/16
E16-16FF90L	1	17/16 - 12	71.0	2.79	122.0	4.80	114	4.48	41	15/8

Reference Hose Section for Coupling Compatibility

COUPLINGS

MA SAE 45° MALE

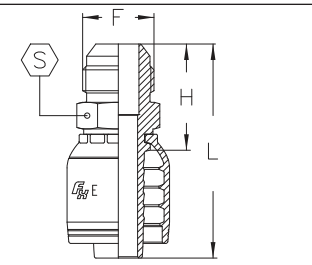

PART NUMBER	Hose Bore	F	H		L		S	
	INCH		[mm]	[in]	[mm]	[in]	[mm]	[in]
E06-06MA	3/8	5/8 - 18	28.2	1.11	58.7	2.21	16	5/8
E12-12MA	3/4	1 1/16 - 14	43.4	1.71	83.9	3.30	27	1 1/16

FA SAE 45° FEMALE SWIVEL

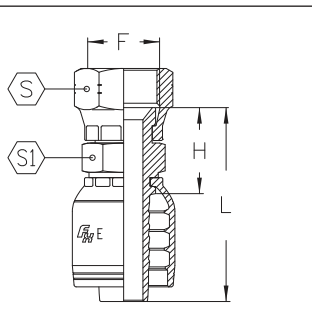

PART NUMBER	Hose Bore	F	H		L		S		S1	
	INCH		[mm]	[in]	[mm]	[in]	[mm]	[in]	[mm]	[in]
E04-06FA	1/4	5/8 - 18	23.0	0.90	51.0	2.01	22	7/8	17	1 1/16
E06-06FA	3/8	5/8 - 18	23.5	0.92	54.0	2.12	22	7/8	16	5/8
E10-12FA	5/8	1 1/16 - 14	31.8	1.25	78.0	3.07	32	1 1/4	25	1
E12-12FA	3/4	1 1/16 - 14	31.8	1.25	72.3	3.27	32	1 1/4	27	1

FA45 SAE 45° FEMALE SWIVEL - 45° ELBOW

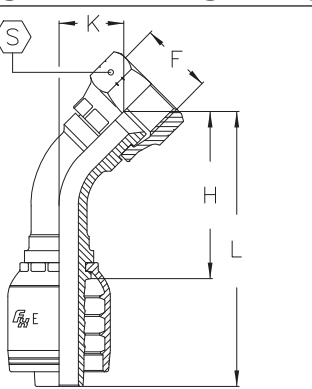

PART NUMBER	Hose Bore	F	H		L		K		S	
	INCH		[mm]	[in]	[mm]	[in]	[mm]	[in]	[mm]	[in]
E06-06FA45	3/8	5/8 - 18	39	1.53	69.5	2.74	16	0.63	22	7/8
E12-12FA45	3/4	1 1/16 - 14	62	2.44	103	4.05	25	0.98	32	1 1/4

FA90 SAE 45° FEMALE SWIVEL - 90° ELBOW

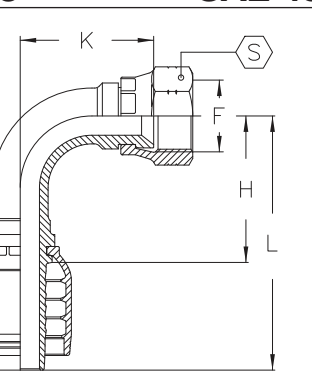

PART NUMBER	Hose Bore	F	H		L		K		S	
	INCH		[mm]	[in]	[mm]	[in]	[mm]	[in]	[mm]	[in]
E06-06FA90	3/8	5/8 - 18	31	1.22	61	2.40	31	1.22	22	7/8
E12-12FA90	3/4	1 1/16 - 14	55	2.16	95	3.74	51	2.01	32	1 1/4

Reference Hose Section for Coupling Compatibility

COUPLINGS

MOB O-RING BOSS MALE

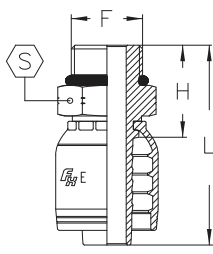

PART NUMBER	Hose Bore	F	H		L		S	
	INCH		[mm]	[in]	[mm]	[in]	[mm]	[in]
E04-04MOB	1/4	7/16 - 20	21.7	0.85	49.7	1.96	14	9/16
E04-05MOB	1/4	1/2 - 20	22.2	0.87	50.2	1.98	16	5/8
E04-06MOB	1/4	9/16 - 18	23.5	0.92	51.5	2.03	17	11/16
E06-06MOB	3/8	9/16 - 18	23.5	0.92	54.0	2.12	17	11/16
E06-08MOB	3/8	3/4 - 16	26.2	1.03	56.7	2.23	22	7/8
E06-10MOB	3/8	7/8 - 14	28.0	1.10	58.5	2.30	25	1
E08-08MOB	1/2	3/4 - 16	27.2	1.07	60.2	2.37	22	7/8
E08-10MOB	1/2	7/8 - 14	29.7	1.17	62.7	2.47	25	1
E08-12MOB	1/2	1 1/16 - 12	33.6	1.32	66.6	2.62	32	1 1/4
E10-10MOB	5/8	7/8 - 14	29.9	1.18	65.7	2.59	25	1
E10-12MOB	5/8	1 1/16 - 12	33.8	1.33	69.6	2.74	32	1 1/4
E12-12MOB	3/4	1 1/16 - 12	34.6	1.36	75.1	2.96	32	1 1/4
E12-16MOB	3/4	1 5/16 - 12	36.1	1.42	76.6	3.01	38	1 1/2
E16-16MOB	1	1 5/16 - 12	37.6	1.48	88.6	3.49	38	1 1/2

MOBX O-RING BOSS MALE SWIVEL

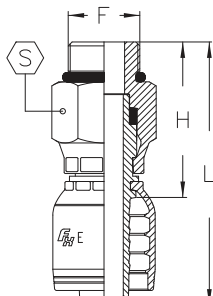

PART NUMBER	Hose Bore	F	H		L		S	
	INCH		[mm]	[in]	[mm]	[in]	[mm]	[in]
E04-04MOBX	1/4	7/16 - 20	37	1.46	65	2.56	17	1 1/16
E06-06MOBX	3/8	9/16 - 18	42	1.65	73	2.87	22	7/8
E06-08MOBX	3/8	3/4 - 16	47	1.85	80	3.15	27	1 1/16
E08-08MOBX	1/2	3/4 - 16	49	1.93	82	3.23	27	1 1/16
E08-10MOBX	1/2	7/8 - 14	50	1.97	83	3.27	27	1 1/16
E12-12MOBX	3/4	1 1/16 - 12	59	2.32	99	3.90	34	1 3/8

MOBX90B O-RING BOSS MALE SWIVEL - 90° BLOCK ELBOW

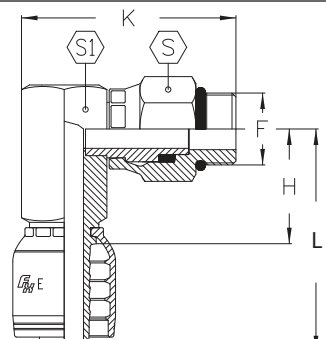

PART NUMBER	Hose Bore	F	H		L		K		S	
	INCH		[mm]	[in]	[mm]	[in]	[mm]	[in]	[mm]	[in]
E06-06MOBX90B	3/8	9/16 - 18	31	1.22	61	2.40	47	1.85	22	7/8
E06-08MOBX90B	3/8	3/4 - 16	34	1.34	64	2.52	54	2.12	27	1 1/16
E08-08MOBX90B	1/2	3/4 - 16	33	1.30	66	2.60	54	2.12	27	1 1/16
E08-10MOBX90B	1/2	7/8 - 14	33	1.30	66	2.60	56	2.20	27	1 1/16
E12-12MOBX90B	3/4	1 1/16 - 12	43	1.69	84	3.31	67	2.64	34	1 3/8

Reference Hose Section for Coupling Compatibility

COUPLINGS

MIX

SAE INVERTED FLARE MALE SWIVEL

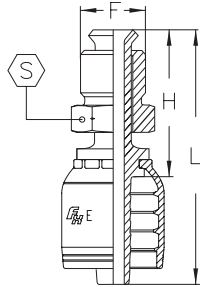

PART NUMBER	Hose Bore	F	H		L		S	
	INCH		[mm]	[in]	[mm]	[in]	[mm]	[in]
E04-03MIX	1/4	3/8 - 24	38.3	1.51	66.8	2.63	9.5	3/8
E04-04MIX	1/4	7/16 - 24	39.1	1.54	67.8	2.67	11.1	7/16
E04-05MIX	1/4	1/2 - 20	42.2	1.66	70.6	2.78	12.0	1/2
E06-04MIX	3/8	7/16 - 24	39.9	1.57	70.6	2.78	11.1	7/16
E06-05MIX	3/8	1/2 - 20	42.4	1.67	73.1	2.88	12.0	1/2
E06-06MIX	3/8	5/8 - 18	43.7	1.72	74.4	2.93	16.0	5/8
E06-07MIX	3/8	11/16 - 18	45.7	1.80	76.2	3.00	17.0	11/16
E06-08MIX	3/8	3/4 - 18	48.5	1.91	79.2	3.12	19.0	3/4
E08-08MIX	1/2	3/4 - 18	49.0	1.93	82.3	3.24	19.0	3/4
E08-10MIX	1/2	7/8 - 18	52.3	2.06	85.6	3.37	22.0	7/8

MIX45

SAE INVERTED FLARE MALE SWIVEL - 45° ELBOW

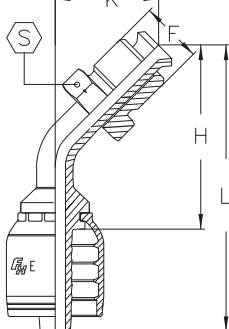

PART NUMBER	Hose Bore	F	H		L		K		S	
	INCH		[mm]	[in]	[mm]	[in]	[mm]	[in]	[mm]	[in]
E04-03MIX45	1/4	3/8 - 24	41.6	1.64	70.1	2.76	13.5	0.53	9.5	3/8
E04-04MIX45	1/4	7/16 - 24	51.8	2.04	80.3	3.16	14.5	0.57	11.1	7/16
E04-05MIX45	1/4	1/2 - 20	52.1	2.05	81.5	3.21	16.5	0.65	12.0	1/2
E06-04MIX45	3/8	7/16 - 24	52.1	2.05	82.6	3.25	14.5	0.57	11.1	7/16
E06-05MIX45	3/8	1/2 - 20	50.0	1.97	80.5	3.17	16.5	0.65	12.0	1/2
E06-06MIX45	3/8	5/8 - 18	52.6	2.07	83.0	3.27	18.0	0.71	16.0	5/8
E06-07MIX45	3/8	11/16 - 18	57.4	2.26	87.9	3.46	19.3	0.76	17.0	11/16
E06-08MIX45	3/8	3/4 - 18	63.0	2.48	93.5	3.68	21.6	0.85	19.0	3/4
E08-08MIX45	1/2	3/4 - 18	64.8	2.55	97.8	3.85	21.6	0.85	19.0	3/4

MIX90

SAE INVERTED FLARE MALE SWIVEL - 90° ELBOW

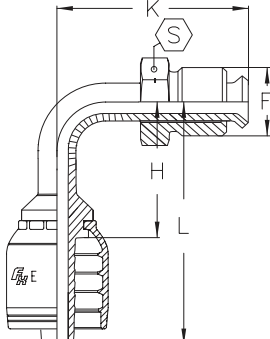

PART NUMBER	Hose Bore	F	H		L		K		S	
	INCH		[mm]	[in]	[mm]	[in]	[mm]	[in]	[mm]	[in]
E04-03MIX90	1/4	3/8 - 24	32.5	1.28	61.0	2.40	24.6	0.97	9.5	3/8
E04-04MIX90	1/4	7/16 - 24	40.4	1.59	68.8	2.71	27.9	1.10	11.1	7/16
E04-05MIX90	1/4	1/4 - 20	42.7	1.68	71.1	2.80	32.5	1.28	12.0	1/2
E06-04MIX90	3/8	7/16 - 24	40.6	1.60	71.1	2.80	27.9	1.10	11.1	7/16
E06-05MIX90	3/8	1/2 - 20	43.4	1.71	73.9	2.91	32.5	1.28	12.0	1/2
E06-06MIX90	3/8	5/8 - 18	48.3	1.90	78.7	3.10	36.8	1.45	16.0	5/8
E06-07MIX90	3/8	11/16 - 18	53.3	2.10	83.8	3.30	40.6	1.60	17.0	11/16
E06-08MIX90	3/8	3/4 - 18	55.6	2.19	86.1	3.39	45.2	1.78	19.0	3/4
E08-08MIX90	1/2	3/4 - 18	56.1	2.21	89.1	3.51	45.2	1.78	19.0	3/4

Reference Hose Section for Coupling Compatibility

COUPLINGS

MRNS SAE FLARELESS MALE ASSEMBLY

PART NUMBER	Hose Bore	F	H		L		S		S1	
	INCH		[mm]	[in]	[mm]	[in]	[mm]	[in]	[mm]	[in]
	E04-04MRNS		1/4	7/16 - 20	24.0	0.94	51.0	2.01	14	9/16
E04-05MRNS	1/4	1/2 - 20	25.3	1.00	53.0	2.09	17	11/16	16	5/8
E06-05MRNS	3/8	1/2 - 20	26.0	1.02	55.6	2.19	17	11/16	16	5/8
E06-06MRNS	3/8	9/16 - 18	26.8	1.05	55.6	2.19	17	11/16	17	11/16
E06-08MRNS	3/8	3/4 - 16	30.0	1.18	58.5	2.30	19	3/4	22	7/8
E08-08MRNS	1/2	3/4 - 16	30.4	1.20	61.3	2.41	19	3/4	22	7/8
E08-10MRNS	1/2	7/8 - 14	32.3	1.27	63.4	2.50	24	1	25	1
E12-12MRNS	3/4	1 1/16 - 12	35.7	1.40	74.7	2.94	27	1 1/16	32	1 1/4

FG FEMALE GREASE

PART NUMBER	Hose Bore	F	H		L		S	
	INCH		[mm]	[in]	[mm]	[in]	[mm]	[in]
	E04-08FG		1/4	1/2 - 27	23.5	0.92	44	1.73
E06-08FG	3/8	1/2 - 27	23.5	0.92	48	1.89	19	3/4

FJIS JIS FEMALE SWIVEL (TOYOTA)

PART NUMBER	Hose Bore	F	H		L		S		S1	
	INCH		[mm]	[in]	[mm]	[in]	[mm]	[in]	[mm]	[in]
	E04-04FJIS		1/4	1/4 - 19	24	0.94	52	2.05	19	3/4
E06-06FJIS	3/8	3/8 - 19	26	1.02	57	2.24	22	7/8	17	11/16
E08-08FJIS	1/2	1/2 - 14	30	1.18	63	2.48	27	1 1/16	22	7/8
E12-12FJIS	3/4	3/4 - 14	36	1.42	76	2.99	32	1 1/4	27	1 1/16
E16-16FJIS	1	1 - 11	40	1.57	91	3.58	41	1 5/8	32	1 1/4

FJIS90 JIS FEMALE SWIVEL - 90° ELBOW

PART NUMBER	Hose Bore	F	H		L		K		S	
	INCH		[mm]	[in]	[mm]	[in]	[mm]	[in]	[mm]	[in]
	E04-04FJIS90		1/4	1/4 - 19	27	1.06	53	2.08	27	1.06
E06-06FJIS90	3/8	3/8 - 19	30	1.18	63	2.48	29	1.14	22	7/8
E08-08FJIS90	1/2	1/2 - 14	41	1.61	70	2.75	38	1.49	27	1 1/16

Reference Hose Section for Coupling Compatibility

COUPLINGS

FK KOMATSU FEMALE SWIVEL

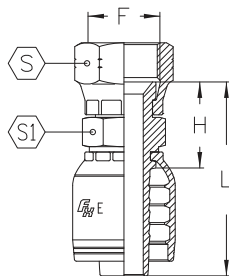

PART NUMBER	Hose Bore	F	H		L		S		S1	
	INCH		[mm]	[in]	[mm]	[in]	[mm]	[in]	[mm]	[in]
E04-14FK	1/4	M14 x 1.5	24.0	0.94	52.5	2.06	19.0	3/4	19	3/4
E04-18FK	1/4	M18 x 1.5	24.0	0.94	52.5	2.06	24.0	1	19	3/4
E06-14FK	3/8	M14 x 1.5	24.0	0.94	54.5	2.14	19.0	3/4	19	3/4
E06-16FK	3/8	M16 x 1.5	22.2	0.87	52.7	2.07	22.0	7/8	19	3/4
E06-18FK	3/8	M18 x 1.5	24.3	0.95	54.8	2.15	24.0	1	19	3/4
E06-20FK	3/8	M20 x 1.5	29.0	1.14	59.0	2.32	25.4	1	22	7/8
E06-22FK	3/8	M22 x 1.5	29.0	1.14	59.0	2.32	27.0	1 1/16	22	7/8
E08-18FK	1/2	M18 x 1.5	26.0	1.02	59.0	2.32	24.0	1	22	7/8
E08-22FK	1/2	M22 x 1.5	26.5	1.04	59.5	2.34	27.0	1 1/16	27	1 1/16
E08-24FK	1/2	M24 x 1.5	29.9	1.17	62.9	2.47	32.0	1 1/4	32	1 1/4
E10-24FK	5/8	M24 x 1.5	29.9	1.17	65.9	2.59	32.0	1 1/4	32	1 1/4
E12-30FK	3/4	M30 x 1.5	33.0	1.29	74.0	2.91	36.0	1 7/16	36	1 7/16
E12-33FK	3/4	M33 x 1.5	34.5	1.35	76.5	3.01	41.0	1 5/8	36	1 7/16
E16-33FK	1	M33 x 1.5	34.5	1.35	89.5	3.52	41.0	1 5/8	36	1 7/16
E16-36FK	1	M36 x 1.5	39.0	1.53	90.5	3.56	46.0	1 13/16	41	1 5/8

FK45 KOMATSU FEMALE SWIVEL- 45° ELBOW

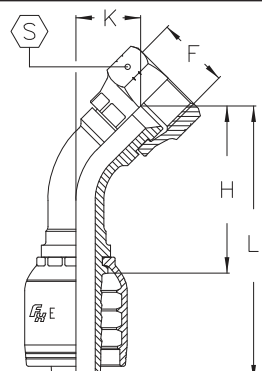

PART NUMBER	Hose Bore	F	H		L		K		S	
	INCH		[mm]	[in]	[mm]	[in]	[mm]	[in]	[mm]	[in]
E04-14FK45	1/4	M14 x 1.5	34.0	1.33	62.0	2.44	16	0.62	19	3/4
E04-18FK45	1/4	M18 x 1.5	33.0	1.29	61.0	2.40	16	0.62	24	1
E06-18FK45	3/8	M18 x 1.5	41.0	1.61	71.5	2.81	19	0.74	24	1
E08-22FK45	1/2	M22 x 1.5	53.5	2.10	86.5	3.40	25	0.98	27	1 1/16
E10-24FK45	5/8	M24 x 1.5	54.0	2.12	89.8	3.53	26	1.02	32	1 1/4
E12-30FK45	3/4	M30 x 1.5	59.5	2.34	100.0	3.93	28	1.10	36	1 7/16

FK90 KOMATSU FEMALE SWIVEL- 90° ELBOW

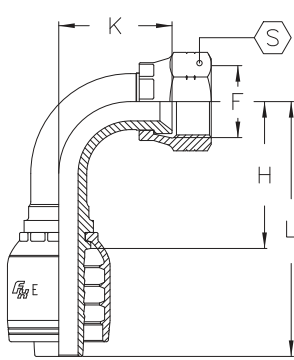

PART NUMBER	Hose Bore	F	H		L		K		S	
	INCH		[mm]	[in]	[mm]	[in]	[mm]	[in]	[mm]	[in]
E04-14FK90	1/4	M14 x 1.5	25.0	0.98	53.0	2.08	28	1.10	19	3/4
E04-16FK90	1/4	M16 x 1.5	29.0	1.14	54.0	2.12	29	1.14	19	3/4
E04-18FK90	1/4	M18 x 1.5	24.0	0.94	52.0	2.04	30	1.18	24	1
E06-18FK90	3/8	M18 x 1.5	31.0	1.22	61.5	2.42	37	1.45	24	1
E08-22FK90	1/2	M22 x 1.5	41.0	1.61	74.0	2.91	48	1.88	27	1 1/16
E10-24FK90	5/8	M24 x 1.5	42.0	1.65	77.8	3.06	50	1.96	32	1 1/4
E12-30FK90	3/4	M30 x 1.5	48.5	1.90	89.0	3.50	57	2.24	36	1 7/16

Reference Hose Section for Coupling Compatibility

COUPLINGS

FLK KOMATSU FLANGE

	PART NUMBER	Hose Bore	FLANGE	A		H		L	
		INCH		[mm]	[in]	[mm]	[in]	[mm]	[in]
	E08-10FLK	1/2	34mm x .265	34	1.34	49.3	1.94	82.3	3.24
	E10-10FLK	5/8	34mm x .265	34	1.34	49.3	1.94	85.3	3.36

FLK45 KOMATSU FLANGE - 45° ELBOW

	PART NUMBER	Hose Bore	FLANGE	A		H		L		K	
		INCH		[mm]	[in]	[mm]	[in]	[mm]	[in]	[mm]	[in]
	E08-10FLK45	1/2	34mm x .265	34	1.34	71	2.79	104	4.09	27.5	1.08
	E10-10FLK45	5/8	34mm x .265	34	1.34	70	2.75	110	4.33	30.0	1.18

FLK90 KOMATSU FLANGE - 90° ELBOW

	PART NUMBER	Hose Bore	FLANGE	A		H		L		K	
		INCH		[mm]	[in]	[mm]	[in]	[mm]	[in]	[mm]	[in]
	E08-10FLK90-044	1/2	34mm x .265	34	1.34	41	1.61	74	2.91	44	1.73
	E10-10FLK90-049	5/8	34mm x .265	34	1.34	49	1.93	85	3.35	49	1.93

Reference Hose Section for Coupling Compatibility

COUPLINGS

MBSPT BSPT MALE

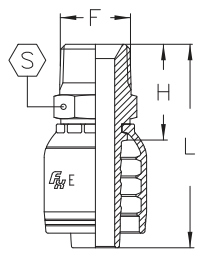

PART NUMBER	Hose Bore	F	H		L		S	
	INCH		[mm]	[in]	[mm]	[in]	[mm]	[in]
E04-02MBSPT	1/4	1/8 - 28	21	0.83	49	1.93	12	1/2
E04-04MBSPT	1/4	1/4 - 19	25	0.98	53	2.09	15	5/8
E04-06MBSPT	1/4	3/8 - 19	26	1.02	54	2.12	19	3/4
E05-06MBSPT	5/16	3/8 - 19	26	1.02	54	2.12	19	3/4
E06-04MBSPT	3/8	1/4 - 19	26	1.02	56	2.20	15	5/8
E06-06MBSPT	3/8	3/8 - 19	27	1.06	57	2.24	19	3/4
E06-08MBSPT	3/8	1/2 - 14	32	1.26	63	2.48	22	7/8
E08-06MBSPT	1/2	3/8 - 19	28	1.10	61	2.52	19	3/4
E08-08MBSPT	1/2	1/2 - 14	33	1.30	66	2.60	22	7/8
E10-12MBSPT	5/8	3/4 - 14	35	1.38	71	2.79	27	1 1/16
E12-12MBSPT	3/4	3/4 - 14	36	1.41	77	3.03	27	1 1/16
E16-16MBSPT	1	1 - 11	43	1.69	94	3.70	36	1 7/16

MBSPP BSPP MALE

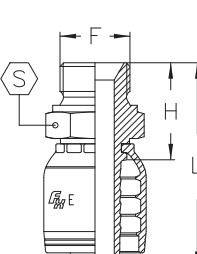

PART NUMBER	Hose Bore	F	H		L		S	
	INCH		[mm]	[in]	[mm]	[in]	[mm]	[in]
E04-02MBSPP	1/4	1/8 - 28	20	0.79	48	1.89	14	9/16
E04-04MBSPP	1/4	1/4 - 19	25	0.98	53	2.09	19	3/4
E04-06MBSPP	1/4	3/8 - 19	27	1.06	55	2.16	22	7/8
E05-06MBSPP	5/16	3/8 - 19	27	1.06	55	2.16	22	7/8
E06-04MBSPP	3/8	1/4 - 19	25	0.98	55	2.16	19	3/4
E06-06MBSPP	3/8	3/8 - 19	27	1.06	58	2.28	22	7/8
E06-08MBSPP	3/8	1/2 - 14	32	1.26	62	2.44	27	1 1/16
E08-06MBSPP	1/2	3/8 - 19	28	1.10	61	2.40	22	7/8
E08-08MBSPP	1/2	1/2 - 14	33	1.30	66	2.60	27	1 1/16
E08-10MBSPP	1/2	5/8 - 14	35	1.38	68	2.68	30	1 3/16
E08-12MBSPP	1/2	3/4 - 14	36	1.42	69	2.72	32	1 1/4
E10-10MBSPP	5/8	5/8 - 14	35	1.38	71	2.79	30	1 3/16
E10-12MBSPP	5/8	3/4 - 14	36	1.42	72	2.83	32	1 1/4
E12-12MBSPP	3/4	3/4 - 14	37	1.46	77	3.03	32	1 1/4
E12-16MBSPP	3/4	1 - 11	42	1.65	82	3.23	41	1 5/8
E16-16MBSPP	1	1 - 11	43	1.69	94	3.70	41	1 5/8

Reference Hose Section for Coupling Compatibility

COUPLINGS

FBSPP BSPP FEMALE SWIVEL

PART NUMBER	Hose Bore	F	H		L		⊕	
	INCH		[mm]	[in]	[mm]	[in]	[mm]	[in]
E04-02FBSPP	1/4	1/8 - 28	17	0.67	45	1.77	14	9/16
E04-04FBSPP	1/4	1/4 - 19	19	0.75	47	1.85	19	3/4
E04-06FBSPP	1/4	3/8 - 19	22	0.87	50	1.97	22	7/8
E05-06FBSPP	5/16	3/8 - 19	22	0.87	50	1.97	22	7/8
E05-08FBSPP	5/16	1/2 - 14	23	0.90	51	2.01	27	1 1/16
E06-04FBSPP	3/8	1/4 - 19	19	0.75	49	1.93	19	3/4
E06-06FBSPP	3/8	3/8 - 19	21	0.83	51	2.01	22	7/8
E06-08FBSPP	3/8	1/2 - 14	23	0.90	54	2.12	27	1 1/16
E08-06FBSPP	1/2	3/8 - 19	22	0.87	56	2.20	22	7/8
E08-08FBSPP	1/2	1/2 - 14	23	0.90	56	2.20	27	1 1/16
E08-10FBSPP	1/2	5/8 - 14	24	0.94	57	2.24	30	1 3/16
E08-12FBSPP	1/2	3/4 - 14	27	1.06	60	2.36	32	1 1/4
E10-10FBSPP	5/8	5/8 - 14	23	0.90	59	2.32	30	1 3/16
E10-12FBSPP	5/8	3/4 - 14	27	1.06	63	2.48	32	1 1/4
E12-12FBSPP	3/4	3/4 - 14	27	1.06	67	2.64	32	1 1/4
E12-16FBSPP	3/4	1 - 11	30	1.18	70	2.75	41	1 5/8
E16-12FBSPP	1	3/4 - 14	28	1.10	79	3.11	32	1 1/4
E16-16FBSPP	1	1 - 11	30	1.18	81	3.19	41	1 5/8
E16-20FBSPP	1	1 1/4 - 11	35	1.38	86	3.38	50	2

FBSPP45 BSPP FEMALE SWIVEL - 45° ELBOW

PART NUMBER	Hose Bore	F	H		L		K		⊕	
	INCH		[mm]	[in]	[mm]	[in]	[mm]	[in]	[mm]	[in]
E04-02FBSPP45	1/4	1/8 - 28	36	1.42	64	2.52	16	0.63	14	9/16
E04-04FBSPP45	1/4	1/4 - 19	37	1.46	65	2.56	16	0.63	19	3/4
E04-06FBSPP45	1/4	3/8 - 19	40	1.57	68	2.68	19	0.75	22	7/8
E05-06FBSPP45	5/16	3/8 - 19	41	1.61	69	2.72	19	0.75	22	7/8
E06-06FBSPP45	3/8	3/8 - 19	42	1.65	73	2.87	19	0.75	22	7/8
E06-08FBSPP45	3/8	1/2 - 14	44	1.73	75	2.95	21	0.83	27	1 1/16
E08-08FBSPP45	1/2	1/2 - 14	49	1.93	82	3.23	22	0.87	27	1 1/16
E08-10FBSPP45	1/2	5/8 - 14	49	1.93	82	3.23	22	0.87	30	1 3/16
E10-10FBSPP45	5/8	5/8 - 14	54	2.12	90	3.54	24	0.94	30	1 3/16
E10-12FBSPP45	5/8	3/4 - 14	57	2.24	93	3.66	26	1.02	32	1 1/4
E12-12FBSPP45	3/4	3/4 - 14	66	2.60	106	4.17	28	1.10	32	1 1/4
E16-16FBSPP45	1	1 - 11	84	3.31	135	5.31	36	1.42	41	1 5/8

Reference Hose Section for Coupling Compatibility

COUPLINGS

FBSP90 BSPP FEMALE SWIVEL - 90° ELBOW

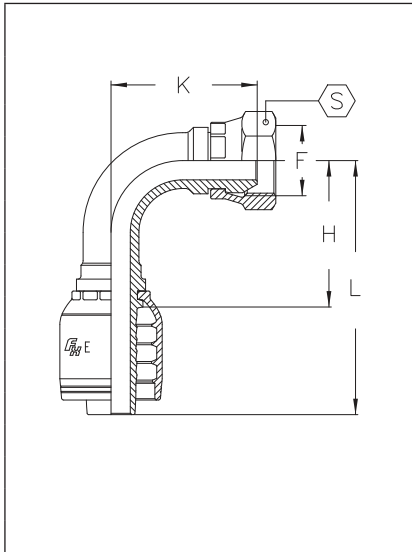

PART NUMBER	Hose Bore	F	H		L		K		S	
	INCH		[mm]	[in]	[mm]	[in]	[mm]	[in]	[mm]	[in]
E04-02FBSP90	1/4	1/8 - 28	26	1.02	54	2.12	28	1.10	14	9/16
E04-04FBSP90	1/4	1/4 - 19	26	1.02	54	2.12	28	1.10	19	3/4
E04-06FBSP90	1/4	3/8 - 19	26	1.02	54	2.12	32	1.26	22	7/8
E05-06FBSP90	5/16	3/8 - 19	28	1.10	56	2.20	34	1.34	22	7/8
E06-06FBSP90	3/8	3/8 - 19	31	1.22	61	2.40	35	1.38	22	7/8
E06-08FBSP90	3/8	1/2 - 14	31	1.22	61	2.40	38	1.50	27	1 1/16
E08-08FBSP90	1/2	1/2 - 14	37	1.46	70	2.75	42	1.65	27	1 1/16
E08-10FBSP90	1/2	5/8 - 14	37	1.46	70	2.75	43	1.69	30	1 3/16
E10-10FBSP90	5/8	5/8 - 14	45	1.77	80	3.15	46	1.81	30	1 3/16
E10-12FBSP90	5/8	3/4 - 14	45	1.77	80	3.15	50	1.97	32	1 1/4
E12-12FBSP90	3/4	3/4 - 14	54	2.12	95	3.74	56	2.20	32	1 1/4
E12-16FBSP90	3/4	1 - 11	54	2.12	95	3.74	59	2.32	41	1 5/8
E16-12FBSP90	1	3/4 - 14	70	2.76	121	4.76	75	2.95	32	1 1/4
E16-16FBSP90	1	1 - 11	70	2.76	121	4.76	72	2.83	41	1 5/8

FBSP90B BSPP FEMALE SWIVEL - 90° BLOCK ELBOW

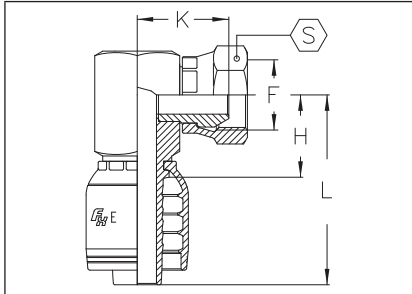

PART NUMBER	Hose Bore	F	H		L		K		S	
	INCH		[mm]	[in]	[mm]	[in]	[mm]	[in]	[mm]	[in]
E04-04FBSP90B	1/4	1/4 - 19	18	0.71	46	1.81	23	0.90	19	3/4
E06-06FBSP90B	3/8	3/8 - 19	21	0.83	52	2.05	26	1.02	22	7/8
E08-08FBSP90B	1/2	1/2 - 14	24	0.94	57	2.24	28	1.10	27	1 1/16
E12-12FBSP90B	3/4	3/4 - 14	31	1.22	72	2.83	35	1.38	32	1 1/4
E16-16FBSP90B	1	1 - 11	38	1.50	89	3.50	41	1.61	41	1 5/8

FBSPFF BSP FLAT FACE FEMALE SWIVEL

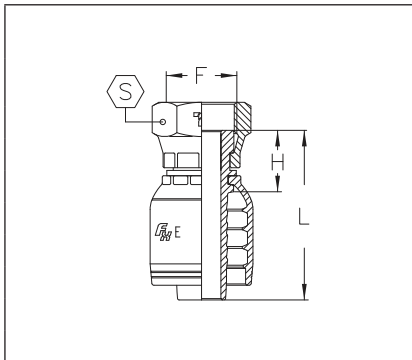

PART NUMBER	Hose Bore	F	H		L		S	
	INCH		[mm]	[in]	[mm]	[in]	[mm]	[in]
E04-04FBSPFF	1/4	1/4 - 19	15	0.59	43	1.69	19	3/4
E04-06FBSPFF	1/4	3/8 - 19	18	0.71	46	1.81	22	7/8
E06-06FBSPFF	3/8	3/8 - 19	17	0.67	47	1.85	22	7/8
E06-08FBSPFF	3/8	1/2 - 14	19	0.75	49	1.93	27	1 1/16
E08-08FBSPFF	1/2	1/2 - 14	19	0.75	52	2.05	27	1 1/16
E08-12FBSPFF	1/2	3/4 - 14	23	0.90	56	2.20	32	1 1/4
E10-10FBSPFF	5/8	5/8 - 14	20	0.79	56	2.20	30	1 3/16
E12-12FBSPFF	3/4	3/4 - 14	22	0.87	63	2.48	32	1 1/4

Reference Hose Section for Coupling Compatibility

COUPLINGS

BJBSP BSP BANJO

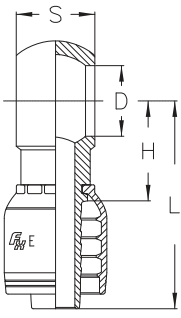

PART NUMBER	Hose Bore	F	D		H		L		S	
	INCH		[mm]	[in]	[mm]	[in]	[mm]	[in]	[mm]	[in]
E04-02BJBSP	1/4	1/8 - 28	10.2	0.40	23.0	0.90	51.0	2.01	10.0	13/32
E04-04BJBSP	1/4	1/4 - 19	13.3	0.52	23.0	0.90	51.0	2.01	14.0	9/16
E04-06BJBSP	1/4	3/8 - 19	16.8	0.66	26.5	1.04	54.5	2.14	17.5	11/16
E06-04BJBSP	3/8	1/4 - 19	13.3	0.52	24.0	0.94	54.5	2.14	14.0	9/16
E06-06BJBSP	3/8	3/8 - 19	16.8	0.66	24.0	0.94	54.5	2.14	17.5	11/16
E06-08BJBSP	3/8	1/2 - 14	21.0	0.83	32.0	1.26	62.5	2.46	23.0	29/32
E08-06BJBSP	1/2	3/8 - 19	16.8	0.66	26.5	1.04	59.5	2.34	17.5	11/16
E08-08BJBSP	1/2	1/2 - 14	21.0	0.83	28.5	1.12	61.5	2.42	23.0	29/32
E12-12BJBSP	3/4	3/4 - 14	26.5	1.04	37.5	1.48	78.0	3.07	29.5	1 5/32
E16-16BJBSP	1	1 - 11	33.5	1.32	49.0	1.93	100.0	3.94	37.5	1 15/32

BJBSPBT BSP BANJO BOLT

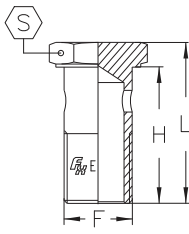

PART NUMBER	F	H		L		S	
		[mm]	[in]	[mm]	[in]	[mm]	[in]
02BJBSPBT	1/8 - 28	26.0	1.02	21.5	0.85	14	9/16
04BJBSPBT	1/4 - 19	34.3	1.35	29.5	1.16	19	3/4
06BJBSPBT	3/8 - 19	40.5	1.59	34.0	1.34	22	7/8
08BJBSPBT	1/2 - 14	46.0	1.81	36.0	1.42	27	1 1/16
10BJBSPBT	5/8 - 14	55.0	2.16	45.5	1.79	30	1 3/16
12BJBSPBT	3/4 - 14	56.0	2.20	48.0	1.89	32	1 1/4
16BJBSPBT	1 - 11	69.0	2.72	59.0	2.32	41	1 5/8

SPML METRIC STANDPIPE LIGHT

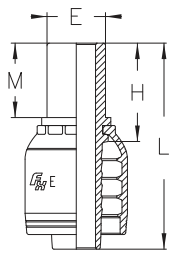

PART NUMBER	Hose Bore	E		H		M		L	
	INCH	[mm]	[in]	[mm]	[in]	[mm]	[in]	[mm]	[in]
E04-06SPML	1/4	6	3/8	27.5	1.08	21	0.83	55.0	2.16
E04-08SPML	1/4	8	1/2	29.5	1.16	23	0.90	58.0	2.28
E04-10SPML	1/4	10	5/8	31.5	1.24	25	0.98	60.0	2.36
E05-10SPML	5/16	10	5/8	31.5	1.24	25	0.98	60.0	2.36
E06-10SPML	3/8	10	5/8	28.5	1.12	22	0.87	59.0	2.32
E06-12SPML	3/8	12	3/4	31.5	1.24	25	0.98	62.0	2.44
E08-15SPML	1/2	15	19/32	31.5	1.24	24	0.94	64.5	2.54
E08-16SPML	1/2	16	4 1/64	36.5	1.44	29	1.14	69.5	2.74
E10-18SPML	5/8	18	23/32	33.5	1.32	26	1.02	69.5	2.74
E10-20SPML	5/8	20	5 1/64	42.5	1.67	35	1.38	78.5	3.09
E12-20SPML	3/4	20	5 1/64	43.5	1.71	35	1.38	84.5	3.33
E12-22SPML	3/4	22	7/8	36.5	1.44	28	1.10	77.5	3.05
E12-25SPML	3/4	25	63/64	47.5	1.87	39	1.53	88.5	3.48
E16-25SPML	1	25	63/64	49.0	1.93	39	1.53	104.0	4.09
E16-28SPML	1	28	1 1/8	39.0	1.53	29	1.14	94.0	3.70
E16-30SPML	1	30	1 3/16	53.0	2.09	43	1.69	108.0	4.25

Reference Hose Section for Coupling Compatibility

COUPLINGS

SPML45 METRIC STANDPIPE LIGHT - 45° ELBOW

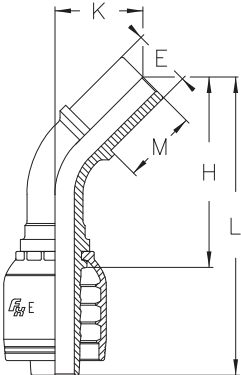

PART NUMBER	Hose Bore	E		H		M		L		K	
	INCH	[mm]	[in]	[mm]	[in]	[mm]	[in]	[mm]	[in]	[mm]	[in]
E04-06SPML45	1/4	6	3/8	48.0	1.89	21	0.83	77.0	3.03	24.0	0.94
E04-08SPML45	1/4	8	1/2	48.0	1.89	23	0.90	76.5	3.01	24.0	0.94
E04-10SPML45	1/4	10	5/8	49.5	1.95	25	0.98	78.0	3.07	25.5	1.00
E05-10SPML45	5/16	10	5/8	51.5	2.03	25	0.98	80.0	3.15	27.5	1.08
E05-12SPML45	5/16	12	3/4	57.5	2.26	25	0.98	86.0	3.38	27.5	1.08
E06-10SPML45	3/8	10	5/8	62.0	2.44	22	0.87	92.5	3.64	27.5	1.08
E06-12SPML45	3/8	12	3/4	62.5	2.46	25	0.98	93.0	3.66	28.5	1.12
E08-15SPML45	1/2	15	19/32	70.5	2.77	24	0.94	103.5	4.07	31.0	1.22
E08-16SPML45	1/2	16	41/64	74.0	2.91	29	1.14	107.0	4.21	34.5	1.36
E10-18SPML45	5/8	18	23/32	86.5	3.40	26	1.02	122.5	4.82	34.0	1.34
E10-20SPML45	5/8	20	51/64	92.5	3.64	35	1.38	128.5	5.06	40.5	1.59
E12-22SPML45	3/4	22	7/8	96.0	3.78	28	1.10	137.0	5.39	42.5	1.67
E12-25SPML45	3/4	25	63/64	103.5	4.07	39	1.53	144.5	5.69	50.0	1.97
E16-28SPML45	1	28	63/64	124.0	4.88	29	1.14	178.0	7.01	56.0	2.20
E16-30SPML45	1	30	13/16	126.5	4.98	43	1.69	181.5	7.14	58.5	2.30

SPML90 METRIC STANDPIPE LIGHT - 90° ELBOW

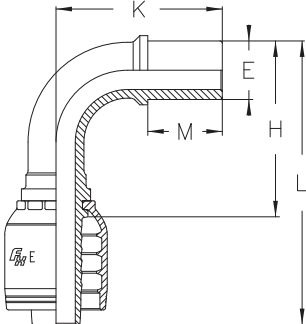

PART NUMBER	Hose Bore	E		H		M		L		K	
	INCH	[mm]	[in]	[mm]	[in]	[mm]	[in]	[mm]	[in]	[mm]	[in]
E04-06SPML90	1/4	6.0	3/8	24	0.94	21	0.83	52	2.05	39.0	1.53
E04-08SPML90	1/4	8.0	1/2	24	0.94	23	0.90	52	2.05	39.0	1.53
E04-10SPML90	1/4	10.0	5/8	24	0.94	25	0.98	52	2.05	41.0	1.61
E05-10SPML90	5/16	10.0	5/8	31	1.22	25	0.98	59	2.32	45.0	1.77
E06-10SPML90	3/8	10.0	5/8	34	1.34	22	0.87	64	2.52	48.0	1.89
E06-12SPML90	3/8	12.0	3/4	34	1.34	25	0.98	64	2.52	49.0	1.93
E08-15SPML90	1/2	15.0	19/32	41	1.61	24	0.94	74	2.91	53.5	2.11
E08-16SPML90	1/2	16.0	41/64	41	1.61	29	1.14	74	2.91	58.5	2.30
E10-18SPML90	5/8	18.0	23/32	49	1.93	26	1.02	85	3.35	61.5	2.42
E10-20SPML90	5/8	20.0	51/64	49	1.93	35	1.38	85	3.35	70.5	2.77
E12-20SPML90	3/4	20.0	51/64	58	2.28	35	1.38	99	3.90	78.0	3.07
E12-22SPML90	3/4	22.0	7/8	58	2.28	28	1.10	99	3.90	71.0	2.79
E12-25SPML90	3/4	25.0	63/64	58	2.28	39	1.53	99	3.90	82.0	3.23
E16-25SPML90	1	25.0	63/64	74	2.91	39	1.53	129	5.08	99.0	3.90
E16-28SPML90	1	28.0	63/64	74	2.91	29	1.14	129	5.08	89.0	3.50

Reference Hose Section for Coupling Compatibility

COUPLINGS

BJM METRIC BANJO

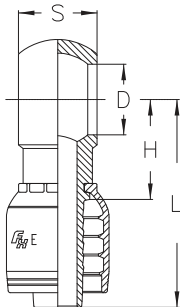

PART NUMBER	Hose Bore	F	D		H		L		S	
	INCH		[mm]	[in]	[mm]	[in]	[mm]	[in]	[mm]	[in]
E04-12BJM	1/4	M12 x 1.5	12.1	0.48	23.0	0.90	51	2.01	12.0	1/2
E04-14BJM	1/4	M14 x 1.5	14.2	0.56	23.0	0.90	51	2.01	14.0	9/16
E05-14BJM	5/16	M14 x 1.5	14.2	0.56	24.0	0.94	52	2.05	17.5	11/16
E05-16BJM	5/16	M16 x 1.5	16.2	0.64	26.5	1.04	54.5	2.14	17.5	11/16
E06-14BJM	3/8	M14 x 1.5	14.2	0.56	24.0	0.94	54.5	2.14	14.0	9/16
E06-16BJM	3/8	M16 x 1.5	16.2	0.64	24.0	0.94	54.5	2.14	17.5	11/16
E06-18BJM	3/8	M18 x 1.5	18.2	0.72	27.0	1.06	57.5	2.26	20.5	13/16
E08-18BJM	1/2	M18 x 1.5	18.2	0.72	28.1	1.11	61.1	2.40	20.5	13/16
E08-22BJM	1/2	M22 x 1.5	22.2	0.87	28.5	1.12	61.5	2.42	22.5	57/64
E10-22BJM	5/8	M22 x 1.5	22.2	0.87	27.2	1.07	63	2.48	22.5	57/64
E12-26BJM	3/4	M26 x 1.5	26.5	1.04	41.5	1.63	78	3.07	29.5	15/32

BJMBT METRIC BANJO BOLT

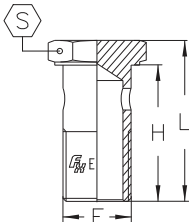

PART NUMBER	F	H		L		S	
		[mm]	[in]	[mm]	[in]	[mm]	[in]
10BJMBT	M10 x 1.5	26.0	1.02	21.5	0.85	14	9/16
12BJMBT	M12 x 1.5	31.0	1.22	25.5	1.00	17	11/16
14BJMBT	M14 x 1.5	37.5	1.48	30.5	1.20	19	3/4
16BJMBT	M16 x 1.5	40.0	1.57	32.5	1.28	22	7/8
18BJMBT	M18 x 1.5	44.0	1.73	36.5	1.44	24	1
20BJMBT	M20 x 1.5	48.0	1.89	39.5	1.55	27	1 1/16
22BJMBT	M22 x 1.5	50.0	1.97	41.5	1.63	28	1 1/8
26BJMBT	M26 x 1.5	58.0	2.28	48.5	1.91	32	1 1/4
30BJMBT	M30 x 1.5	64.0	2.52	53.0	2.09	36	1 7/16

MML METRIC LIGHT MALE (24° CONE SEAT) - CEL

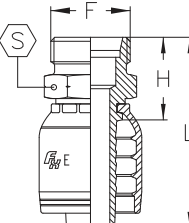

PART NUMBER	Hose Bore	F	Tube	H		L		S	
	INCH			[mm]	[in]	[mm]	[in]	[mm]	[in]
E04-12MML	1/4	M12 x 1.5	L6	21	0.83	49	1.93	12	1/2
E04-14MML	1/4	M14 x 1.5	L8	21	0.83	49	1.93	14	9/16
E04-16MML	1/4	M16 x 1.5	L10	23	0.90	51	2.01	17	11/16
E04-18MML	1/4	M18 x 1.5	L12	23	0.90	51	2.01	19	3/4
E05-16MML	5/16	M16 x 1.5	L10	23	0.90	51	2.01	17	11/16
E05-18MML	5/16	M18 x 1.5	L12	23	0.90	51	2.01	19	3/4
E06-16MML	3/8	M16 x 1.5	L10	23	0.90	53	2.09	17	11/16
E06-18MML	3/8	M18 x 1.5	L12	23	0.90	53	2.09	19	3/4
E06-22MML	3/8	M22 x 1.5	L15	25	0.98	56	2.20	22	7/8
E08-22MML	1/2	M22 x 1.5	L15	26	1.02	59	2.32	22	7/8
E08-26MML	1/2	M26 x 1.5	L18	28	1.10	61	2.40	27	1 1/16
E10-26MML	5/8	M26 x 1.5	L18	28	1.10	64	2.52	27	1 1/16
E10-30MML	5/8	M30 x 2.0	L22	30	1.18	66	2.60	30	1 3/16
E12-26MML	3/4	M26 x 1.5	L18	29	1.14	70	2.75	27	1 1/16
E12-30MML	3/4	M30 x 2.0	L22	31	1.22	72	2.83	30	1 3/16
E16-36MML	1	M36 x 2.0	L28	35	1.38	86	3.38	36	1 7/16

Reference Hose Section for Coupling Compatibility

COUPLINGS

FML FEMALE METRIC LIGHT SWIVEL (24° SEAT) - DKOL

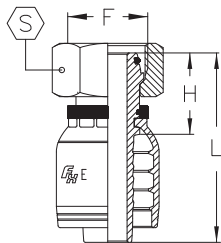

PART NUMBER	Hose Bore	F	Tube	H		L		S	
	INCH			[mm]	[in]	[mm]	[in]	[mm]	[in]
E04-12FML	¼	M12 x 1.5	L6	23	0.90	51	2.01	17	11/16
E04-14FML	¼	M14 x 1.5	L8	22	0.87	50	1.97	17	11/16
E04-16FML	¼	M16 x 1.5	L10	24	0.94	52	2.05	19	¾
E04-18FML	¼	M18 x 1.5	L12	24	0.94	52	2.05	22	7/8
E05-16FML	5/16	M16 x 1.5	L10	24	0.94	52	2.05	19	¾
E05-18FML	5/16	M18 x 1.5	L12	24	0.94	52	2.05	22	7/8
E06-16FML	¾	M16 x 1.5	L10	23	0.90	54	2.12	19	¾
E06-18FML	¾	M18 x 1.5	L12	24	0.94	54	2.12	22	7/8
E06-22FML	¾	M22 x 1.5	L15	24	0.94	54	2.12	27	1 1/16
E08-22FML	½	M22 x 1.5	L15	24	0.94	57	2.24	27	1 1/16
E08-26FML	½	M26 x 1.5	L18	26	1.02	59	2.32	32	1 ¼
E10-26FML	5/8	M26 x 1.5	L18	27	1.06	62	2.44	32	1 ¼
E10-30FML	5/8	M30 x 2.0	L22	28	1.10	64	2.52	36	1 7/16
E12-26FML	¾	M26 x 1.5	L18	34	1.34	75	2.95	32	1 ¼
E12-30FML	¾	M30 x 2.0	L22	31	1.22	71	2.79	36	1 7/16
E16-36FML	1	M36 x 2.0	L28	32	1.26	83	3.27	41	1 5/8

FML45 FEMALE METRIC LIGHT SWIVEL - 45° ELBOW (24° SEAT) - DKOL

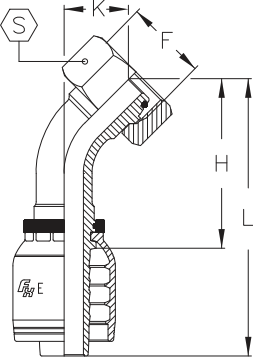

PART NUMBER	Hose Bore	F	Tube	H		L		K		S	
	INCH			[mm]	[in]	[mm]	[in]	[mm]	[in]	[mm]	[in]
E04-12FML45	¼	M12 x 1.5	L6	35	1.38	63	2.48	14	0.55	17	11/16
E04-14FML45	¼	M14 x 1.5	L8	36	1.42	64	2.52	14	0.55	17	11/16
E04-16FML45	¼	M16 x 1.5	L10	38	1.50	66	2.60	16	0.63	19	¾
E04-18FML45	¼	M18 x 1.5	L12	39	1.53	67	2.64	17	0.67	22	7/8
E05-16FML45	5/16	M16 x 1.5	L10	39	1.53	67	2.64	17	0.67	19	¾
E05-18FML45	5/16	M18 x 1.5	L12	39	1.53	67	2.64	18	0.71	22	7/8
E06-16FML45	¾	M16 x 1.5	L10	39	1.53	69	2.72	16	0.63	19	¾
E06-18FML45	¾	M18 x 1.5	L12	40	1.57	71	2.79	18	0.71	22	7/8
E06-22FML45	¾	M22 x 1.5	L15	42	1.65	72	2.83	19	0.75	27	1 1/16
E08-22FML45	½	M22 x 1.5	L15	46	1.81	79	3.11	19	0.75	27	1 1/16
E08-26FML45	½	M26 x 1.5	L18	47	1.85	80	3.15	21	0.83	32	1 ¼
E10-26FML45	5/8	M26 x 1.5	L18	53	2.09	89	3.50	22	0.87	32	1 ¼
E10-30FML45	5/8	M30 x 2.0	L22	54	2.12	90	3.54	23	0.90	36	1 7/16
E12-26FML45	¾	M26 x 1.5	L18	66	2.60	107	4.21	29	1.14	32	1 ¼
E12-30FML45	¾	M30 x 2.0	L22	62	2.44	103	4.05	25	0.98	36	1 7/16
E16-36FML45	1	M36 x 2.0	L28	80	3.15	131	5.16	31	1.22	41	1 5/8

Reference Hose Section for Coupling Compatibility

COUPLINGS

FML90

FEMALE METRIC LIGHT SWIVEL - 90° ELBOW (24° SEAT) - DKOL

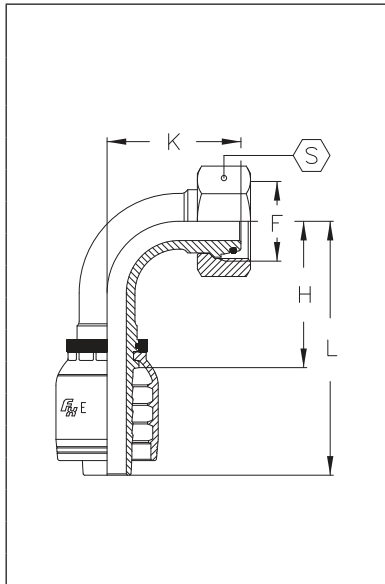

PART NUMBER	Hose Bore	F	Tube	H		L		K		S	
	INCH			[mm]	[in]	[mm]	[in]	[mm]	[in]	[mm]	[in]
E04-12FML90	1/4	M12 x 1.5	L6	26	1.02	53	2.09	26	1.02	17	11/16
E04-14FML90	1/4	M14 x 1.5	L8	29	1.14	57	2.24	29	1.14	17	11/16
E04-16FML90	1/4	M16 x 1.5	L10	29	1.14	57	2.24	30	1.18	19	3/4
E04-18FML90	1/4	M18 x 1.5	L12	29	1.14	57	2.24	32	1.26	22	7/8
E05-16FML90	5/16	M16 x 1.5	L10	31	1.22	59	2.32	33	1.30	19	3/4
E05-18FML90	5/16	M18 x 1.5	L12	28	1.10	56	2.20	32	1.26	22	7/8
E06-16FML90	3/8	M16 x 1.5	L10	31	1.22	61	2.40	31	1.22	19	3/4
E06-18FML90	3/8	M18 x 1.5	L12	31	1.22	61	2.40	33	1.30	22	7/8
E06-22FML90	3/8	M22 x 1.5	L15	31	1.22	61	2.40	35	1.38	27	11/16
E08-22FML90	1/2	M22 x 1.5	L15	37	1.46	70	2.75	38	1.50	27	11/16
E08-26FML90	1/2	M26 x 1.5	L18	37	1.46	70	2.75	40	1.57	32	1 1/4
E10-26FML90	5/8	M26 x 1.5	L18	44	1.73	80	3.15	45	1.77	32	1 1/4
E10-30FML90	5/8	M30 x 2.0	L22	44	1.73	80	3.15	47	1.85	36	1 7/16
E12-30FML90	3/4	M30 x 2.0	L22	54	2.12	94	3.70	52	2.05	36	1 7/16
E16-36FML90	1	M36 x 2.0	L28	70	2.75	121	4.76	66	2.60	41	1 5/8

MMS

MALE METRIC HEAVY (24° SEAT) - CES

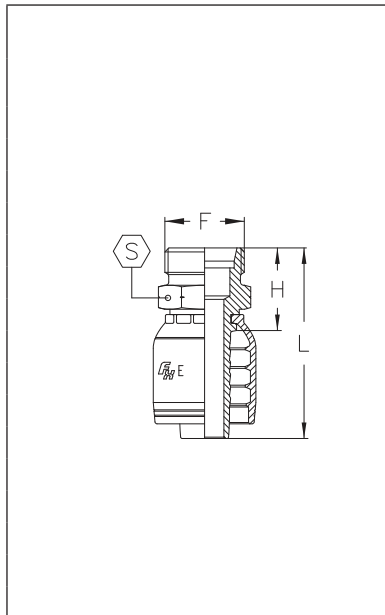

PART NUMBER	Hose Bore	F	Tube	A		B		S	
	INCH			[mm]	[in]	[mm]	[in]	[mm]	[in]
E04-14MMS	1/4	M14 x 1.5	S6	23	0.90	51	2.01	14	9/16
E04-16MMS	1/4	M16 x 1.5	S8	23	0.90	51	2.01	17	11/16
E04-18MMS	1/4	M18 x 1.5	S10	24	0.94	52	2.05	19	3/4
E04-20MMS	1/4	M20 x 1.5	S12	25	0.98	53	2.09	22	7/8
E05-18MMS	5/16	M18 x 1.5	S10	24	0.94	52	2.05	19	3/4
E05-20MMS	5/16	M20 x 1.5	S12	25	0.98	53	2.09	22	7/8
E06-18MMS	3/8	M18 x 1.5	S10	24	0.94	55	2.16	19	3/4
E06-20MMS	3/8	M20 x 1.5	S12	25	0.98	56	2.20	22	7/8
E06-22MMS	3/8	M22 x 1.5	S14	27	1.06	58	2.28	22	7/8
E08-22MMS	1/2	M22 x 1.5	S14	28	1.10	61	2.40	22	7/8
E08-24MMS	1/2	M24 x 1.5	S16	29	1.14	62	2.44	24	1
E10-30MMS	5/8	M30 x 2.0	S20	32	1.26	68	2.68	30	1 3/16
E12-30MMS	3/4	M30 x 2.0	S20	33	1.30	74	2.91	30	1 3/16
E12-36MMS	3/4	M36 x 2.0	S25	37	1.46	78	3.07	36	1 7/16
E16-36MMS	1	M36 x 2.0	S25	39	1.53	90	3.54	36	1 7/16
E16-42MMS	1	M42 x 2.0	S30	43	1.69	94	3.70	46	1 13/16

Reference Hose Section for Coupling Compatibility

COUPLINGS

FMS

FEMALE METRIC HEAVY SWIVEL (24° SEAT) - DKOS

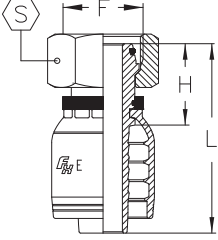

PART NUMBER	Hose Bore	F	Tube	H		L		S	
	INCH			[mm]	[in]	[mm]	[in]	[mm]	[in]
E04-14FMS	1/4	M14 x 1.5	S6	23	0.90	51	2.01	17	1 1/16
E04-16FMS	1/4	M16 x 1.5	S8	22	0.87	50	1.97	19	3/4
E04-18FMS	1/4	M18 x 1.5	S10	24	0.94	52	2.05	22	7/8
E04-20FMS	1/4	M20 x 1.5	S12	24	0.94	52	2.05	24	1
E05-18FMS	5/16	M18 x 1.5	S10	24	0.94	52	2.05	22	7/8
E05-20FMS	5/16	M20 x 1.5	S12	24	0.94	52	2.05	24	1
E06-18FMS	3/8	M18 x 1.5	S10	25	0.98	55	2.16	22	7/8
E06-20FMS	3/8	M20 x 1.5	S12	24	0.94	54	2.12	24	1
E06-22FMS	3/8	M22 x 1.5	S14	28	1.10	58	2.28	27	1 1/16
E08-22FMS	1/2	M22 x 1.5	S14	28	1.10	61	2.40	27	1 1/16
E08-24FMS	1/2	M24 x 1.5	S16	29	1.14	62	2.44	30	1 3/16
E10-30FMS	5/8	M30 x 2.0	S20	33	1.30	69	2.72	36	1 7/16
E12-30FMS	3/4	M30 x 2.0	S20	36	1.42	76	2.99	36	1 7/16
E12-36FMS	3/4	M36 x 2.0	S25	38	1.50	78	3.07	46	1 13/16
E16-36FMS	1	M36 x 2.0	S25	40	1.57	91	3.58	46	1 13/16
E16-42FMS	1	M42 x 2.0	S30	40	1.57	91	3.58	50	2

FMS45

FEMALE METRIC HEAVY SWIVEL - 45° ELBOW (24° SEAT) - DKOS

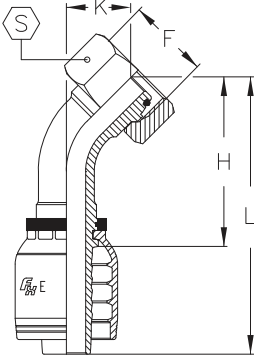

PART NUMBER	Hose Bore	F	Tube	H		L		K		S	
	INCH			[mm]	[in]	[mm]	[in]	[mm]	[in]	[mm]	[in]
E04-14FMS45	1/4	M14 x 1.5	S6	35	1.38	63.0	2.48	14	0.55	17	1 1/16
E04-16FMS45	1/4	M16 x 1.5	S8	36	1.42	64.0	2.52	14	0.55	19	3/4
E04-18FMS45	1/4	M18 x 1.5	S10	38	1.50	66.0	2.60	16	0.63	22	7/8
E04-20FMS45	1/4	M20 x 1.5	S12	39	1.53	67.0	2.64	17	0.67	24	1
E05-18FMS45	5/16	M18 x 1.5	S10	39	1.53	67.0	2.64	17	0.67	22	7/8
E05-20FMS45	5/16	M20 x 1.5	S12	39	1.53	67.0	2.64	18	0.71	24	1
E06-18FMS45	3/8	M18 x 1.5	S10	40	1.57	70.0	2.75	17	0.67	22	7/8
E06-20FMS45	3/8	M20 x 1.5	S12	40	1.57	71.0	2.79	18	0.71	24	1
E06-22FMS45	3/8	M22 x 1.5	S14	42	1.65	72.0	2.83	19	0.75	27	1 1/16
E08-22FMS45	1/2	M22 x 1.5	S14	46	1.81	79.0	3.11	20	0.79	27	1 1/16
E08-24FMS45	1/2	M24 x 1.5	S16	47	1.85	80.0	3.15	21	0.83	30	1 3/16
E10-30FMS45	5/8	M30 x 2.0	S20	56	2.20	92.0	3.62	25	0.98	36	1 7/16
E12-30FMS45	3/4	M30 x 2.0	S20	64	2.52	105.0	4.13	27	1.06	36	1 7/16
E12-36FMS45	3/4	M36 x 2.0	S25	64	2.52	105.0	4.13	28	1.10	46	1 13/16
E16-36FMS45	1	M36 x 2.0	S25	82	3.23	133.0	5.24	34	1.34	41	1 13/16
E16-42FMS45	1	M42 x 2.0	S30	80	3.15	131.0	5.16	31	1.22	50	2

Reference Hose Section for Coupling Compatibility

COUPLINGS

FMS90 FEMALE METRIC HEAVY SWIVEL - 90° ELBOW (24° SEAT) - DKOS

PART NUMBER	Hose Bore	F	Tube	H		L		K		S	
	INCH			[mm]	[in]	[mm]	[in]	[mm]	[in]	[mm]	[in]
E04-14FMS90	¼	M14 x 1.5	S6	25	0.98	53	2.09	26	1.02	17	11/16
E04-16FMS90	¼	M16 x 1.5	S8	29	1.41	57	2.24	29	1.14	19	¾
E04-18FMS90	¼	M18 x 1.5	S10	29	1.41	57	2.24	30	1.18	22	7/8
E04-20FMS90	¼	M20 x 1.5	S12	29	1.41	57	2.24	32	1.26	24	1
E05-18FMS90	5/16	M18 x 1.5	S10	31	1.22	59	2.32	33	1.30	22	7/8
E05-20FMS90	5/16	M20 x 1.5	S12	28	1.10	56	2.20	32	1.26	24	1
E06-18FMS90	3/8	M18 x 1.5	S10	30	1.18	61	2.40	33	1.30	22	7/8
E06-20FMS90	3/8	M20 x 1.5	S12	31	1.22	61	2.40	33	1.30	24	1
E06-22FMS90	3/8	M22 x 1.5	S14	34	1.34	64	2.52	37	1.46	27	1 1/16
E08-22FMS90	½	M22 x 1.5	S14	39	1.53	71	2.79	41	1.61	27	1 1/16
E08-24FMS90	½	M24 x 1.5	S16	39	1.53	71	2.79	42	1.65	30	1 3/16
E10-30FMS90	5/8	M30 x 2.0	S20	44	1.73	80	3.15	49	1.93	36	1 7/16
E12-30FMS90	¾	M30 x 2.0	S20	54	2.12	94	3.70	55	2.16	36	1 7/16
E12-36FMS90	¾	M36 x 2.0	S25	54	2.12	94	3.70	57	2.24	46	1 13/16
E16-36FMS90	1	M36 x 2.0	S25	70	2.75	121	4.76	70	2.75	46	1 13/16
E16-42FMS90	1	M42 x 2.0	S30	70	2.75	121	4.76	66	2.60	50	2

MGAZ FRENCH GAZ MALE

PART NUMBER	Hose Bore	T	Tube	H		L		S	
	INCH			[mm]	[in]	[mm]	[in]	[mm]	[in]
E06-20MGAZ	3/8	M20 x 1.5	13.25	26.7	1.05	57.2	2.25	22	7/8
E08-24MGAZ	½	M24 x 1.5	16.75	30.7	1.20	63.7	2.50	27	1 1/16
E10-30MGAZ	5/8	M30 x 1.5	21.25	31.2	1.22	67.2	2.64	32	1 ¼
E12-30MGAZ	¾	M30 x 1.5	21.25	31.7	1.24	73.2	2.88	32	1 ¼
E12-36MGAZ	¾	M36 x 1.5	26.75	31.7	1.24	73.2	2.88	36	1 7/16
E16-45MGAZ	1	M45 x 1.5	33.50	37.2	1.46	92.2	3.62	46	1 13/16

FGAZ FRENCH GAZ FEMALE

PART NUMBER	Hose Bore	T	Tube	H		L		S	
	INCH			[mm]	[in]	[mm]	[in]	[mm]	[in]
E06-20FGAZ	3/8	M20 x 1.5	13.25	23.8	0.93	54.3	2.13	24	1
E08-24FGAZ	½	M24 x 1.5	16.75	27.3	1.07	60.3	2.37	30	1 3/16
E10-30FGAZ	5/8	M30 x 1.5	21.25	30	1.18	66	2.59	36	1 7/16
E12-30FGAZ	¾	M30 x 1.5	21.25	30.6	1.20	71.6	2.81	36	1 7/16
E12-36FGAZ	¾	M36 x 1.5	26.75	33.6	1.32	74.5	2.93	41	1 5/8
E16-45FGAZ	1	M45 x 1.5	33.50	33.9	1.33	88.9	3.50	50	2

Reference Hose Section for Coupling Compatibility

COUPLINGS

FL SAE CODE 61 FLANGE

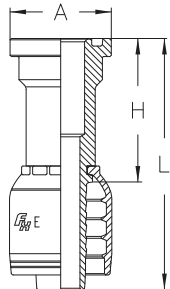

PART NUMBER	Hose Bore	FLANGE Thickness	A		H		L	
	INCH		[mm]	[in]	[mm]	[in]	[mm]	[in]
E08-08FL	1/2	0.265	30.2	1.19	47.0	1.85	80.0	3.15
E08-12FL	1/2	0.265	38.1	1.50	47.0	1.85	80.0	3.15
E10-12FL	5/8	0.265	38.1	1.50	48.0	1.89	84.0	3.30
E12-12FL	3/4	0.265	38.1	1.50	54.0	2.13	94.5	3.72
E12-16FL	3/4	0.315	44.5	1.75	54.0	2.13	94.5	3.72
E16-16FL	1	0.315	44.5	1.75	55.0	2.17	106.0	4.17
E16-20FL	1	0.315	50.8	2.00	55.0	2.17	106.0	4.17
E20-20FL	1 1/4	0.315	50.8	2.00	62.0	2.44	120.0	4.72
E24-24FL	1 1/2	0.315	60.4	2.38	67.5	2.66	132.0	5.20
E32-32FL	2	0.375	71.4	2.81	70.0	2.76	140.0	5.50

FL45 SAE CODE 61 FLANGE - 45° ELBOW

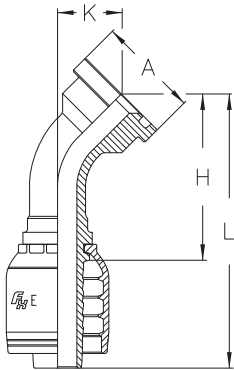

PART NUMBER	Hose Bore	FLANGE Thickness	A		H		L		K	
	INCH		[mm]	[in]	[mm]	[in]	[mm]	[in]	[mm]	[in]
E08-08FL45	1/2	0.265	30.2	1.19	47	1.85	80	3.15	20	0.79
E08-12FL45	1/2	0.265	38.1	1.50	51	2.00	84	3.31	24	0.94
E10-12FL45	5/8	0.265	38.1	1.50	55	2.17	91	3.58	24	0.94
E12-12FL45	3/4	0.265	38.1	1.50	62	2.44	102	4.02	25	0.98
E12-16FL45	3/4	0.315	44.5	1.75	64	2.52	104	4.09	27	1.06
E16-16FL45	1	0.315	44.5	1.75	77	3.03	128	5.04	28	1.10
E16-20FL45	1	0.315	50.8	2.00	77	3.03	128	5.04	28	1.10
E20-20FL45	1 1/4	0.315	50.8	2.00	88	3.46	146	5.75	32	1.26
E24-24FL45	1 1/2	0.315	60.4	2.38	105	4.13	169	6.65	37	1.46
E32-32FL45	2	0.375	71.4	2.81	212	8.35	142	5.59	53	2.09

FL90 SAE CODE 61 FLANGE - 90° ELBOW

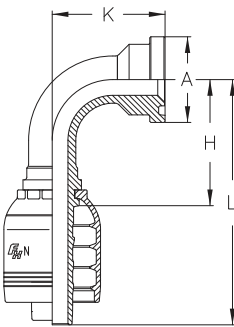

PART NUMBER	Hose Bore	FLANGE Thickness	A		H		L		K	
	INCH		[mm]	[in]	[mm]	[in]	[mm]	[in]	[mm]	[in]
E08-08FL90	1/2	0.265	30.2	1.19	38	1.47	71	2.80	40	1.57
E08-12FL90	1/2	0.265	38.1	1.50	38	1.47	71	2.80	45	1.77
E10-12FL90	5/8	0.265	38.1	1.50	45	1.77	81	3.19	47	1.85
E12-12FL90	3/4	0.265	38.1	1.50	55	2.17	95	3.74	51	2.00
E12-16FL90	3/4	0.315	44.5	1.75	55	2.17	95	3.74	54	2.13
E16-16FL90	1	0.315	44.5	1.75	70	2.76	121	4.76	61	2.40
E16-20FL90	1	0.315	50.8	2.00	70	2.76	121	4.76	61	2.40
E20-20FL90	1 1/4	0.315	50.8	2.00	85	3.35	142	5.59	70	2.76
E24-24FL90	1 1/2	0.315	60.4	2.38	105	4.13	170	6.69	83	3.27
E32-32FL90	2	0.375	71.4	2.81	140	5.51	210	8.27	120	4.72

Reference Hose Section for Coupling Compatibility

COUPLINGS

MPWK PRESSURE WASH GUN END

	PART NUMBER	Hose Bore	H		L	
		INCH	[mm]	[in]	[mm]	[in]
	E04-22MPWK	1/4	34.5	1.35	63	2.48
E05-22MPWK	5/16	34.5	1.35	63	2.48	

FPWK PRESSURE WASH FEMALE SWIVEL TYPE - K

	PART NUMBER	Hose Bore	F	H		L		D	
		INCH		[mm]	[in]	[mm]	[in]	[mm]	[in]
	E04-22FPWK	1/4	M22 x 1.5	36.5	1.44	65	2.56	14	0.55
E05-22FPWK	5/16	M22 x 1.5	36.5	1.44	65	2.56	14	0.55	
E06-22FPWK	3/8	M22 x 1.5	36.5	1.44	67	2.64	14	0.55	

FPWS PRESSURE WASH (SW5)

	PART NUMBER	Hose Bore	H		L	
		INCH	[mm]	[in]	[mm]	[in]
	E04-04FPWS	1/4	32.4	1.27	60	2.36

Reference Hose Section for Coupling Compatibility

COUPLINGS

FPWW PRESSURE WASH FEMALE SWIVEL TYPE - W

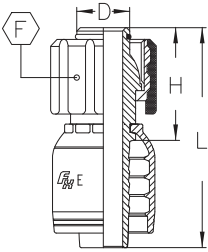

PART NUMBER	Hose Bore	F	H		L		D	
	INCH		[mm]	[in]	[mm]	[in]	[mm]	[in]
E04-22FPWW	1/4	M22 x 1.5	29.5	1.16	61.4	2.41	15	0.59
E05-22FPWW	5/16	M22 x 1.5	29.5	1.16	57.4	2.25	15	0.59

HM HOSE MENDER

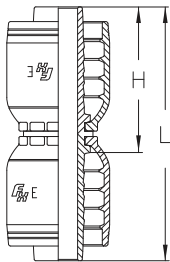

PART NUMBER	Hose Bore	H		L	
	INCH	[mm]	[in]	[mm]	[in]
E04-04HM	1/4	13	0.51	70	2.75
E06-06HM	3/8	13	0.51	74	2.91
E08-08HM	1/2	15	0.59	81	3.18
E12-12HM	3/4	17	0.66	99	3.89
E16-16HM	1	20	0.78	130	5.11

SP IMPERIAL STANDPIPE

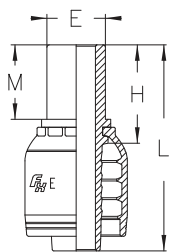

PART NUMBER	Hose Bore	E		H		M		L	
	INCH	[mm]	[in]	[mm]	[in]	[mm]	[in]	[mm]	[in]
E04-04SP	1/4	6.3	1/4	30.5	1.20	23.5	0.92	58.5	2.30
E06-06SP	3/8	9.5	3/8	32.0	1.26	25.0	0.98	62.5	2.46
E08-08SP	1/2	12.7	1/2	32.5	1.28	25.0	0.98	65.5	2.58
E08-10SP	1/2	15.9	5/8	43.0	1.69	35.5	1.40	76.0	2.99
E12-12SP	3/4	19.0	3/4	44.5	1.75	36.0	1.42	85.0	3.35
E16-16SP	1	25.4	1	49.5	1.95	40.0	1.57	10.5	0.41

Reference Hose Section for Coupling Compatibility

COUPLINGS

MP NPT MALE

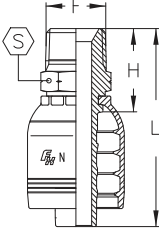

PART NUMBER	Hose Bore	F	H		L		S	
	INCH		[mm]	[in]	[mm]	[in]	[mm]	[in]
N06-06MP	3/8	3/8 - 18	28.6	1.12	59.1	2.33	19	3/4
N06-08MP	3/8	1/2 - 14	34.0	1.34	64.5	2.54	22	7/8
N08-06MP	1/2	3/8 - 18	30.6	1.20	63.6	2.50	22	7/8
N08-08MP	1/2	1/2 - 14	35.0	1.38	68.0	2.68	22	7/8
N08-12MP	1/2	3/4 - 14	36.9	1.45	69.9	2.75	27	1 1/16
N10-12MP	5/8	3/4 - 14	37.1	1.46	72.9	2.87	27	1 1/16
N12-12MP	3/4	3/4 - 14	39.0	1.53	90.0	3.54	27	1 1/16
N12-16MP	3/4	1 - 11 1/2	47.0	1.85	98.0	3.86	36	1 7/16
N16-12MP	1	3/4 - 14	41.5	1.63	98.0	3.86	32	1 1/4
N16-16MP	1	1 - 11 1/2	48.5	1.91	105.0	4.13	36	1 7/16
N16-20MP	1	1 1/4 - 11 1/2	53.0	2.09	109.5	4.31	46	1 13/16
N20-20MP	1 1/4	1 1/4 - 11 1/2	55.0	2.16	121.5	4.78	46	1 13/16
N20-24MP	1 1/4	1 1/2 - 11 1/2	59.0	2.32	125.5	4.94	50	2
N24-24MP	1 1/2	1 1/2 - 11 1/2	61.0	2.40	143.5	5.65	50	2
N32-32MP	2	2 - 11 1/2	70.5	2.77	167.0	6.57	65	2 9/16

MPA API MALE

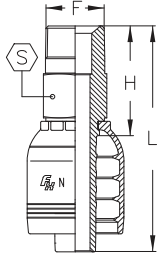

PART NUMBER	Hose Bore	F	H		L		S	
	INCH		[mm]	[in]	[mm]	[in]	[mm]	[in]
N24-24MPA	1 1/2	1 1/4 - 11 1/2	88.0	3.46	170.5	6.71	50	2
N32-32MPA	2	2 - 11 1/2	112.3	4.42	208.8	8.22	65	2 9/16

Reference Hose Section for Coupling Compatibility

COUPLINGS

MJ

JIC 37° MALE

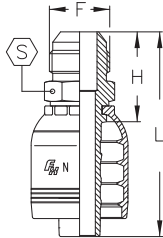

PART NUMBER	Hose Bore	F	H		L		S	
	INCH		[mm]	[in]	[mm]	[in]	[mm]	[in]
N06-06MJ	3/8	9/16 - 18	26.6	1.04	57.1	2.24	15	5/8
N06-08MJ	3/8	3/4 - 16	29.7	1.16	60.2	2.37	19	3/4
N08-08MJ	1/2	3/4 - 16	30.7	1.20	63.7	2.50	19	3/4
N08-10MJ	1/2	7/8 - 14	35.3	1.38	68.3	2.68	24	1
N08-12MJ	1/2	1 1/16 - 12	38.9	1.53	71.9	2.83	27	1 1/16
N10-10MJ	5/8	7/8 - 14	35.5	1.39	71.3	2.80	24	1
N10-12MJ	5/8	1 1/16 - 12	39.1	1.53	74.9	2.94	27	1 1/16
N12-10MJ	3/4	7/8 - 14	37.0	1.45	88.0	3.46	27	1 1/16
N12-12MJ	3/4	1 1/16 - 12	40.0	1.57	91.0	3.58	27	1 1/16
N12-14MJ	3/4	1 3/16 - 12	41.5	1.63	92.5	3.64	32	1 1/4
N12-16MJ	3/4	1 5/16 - 12	43.0	1.69	94.0	3.70	36	1 7/16
N16-16MJ	1	1 5/16 - 12	45.0	1.77	101.5	3.99	36	1 7/16
N16-20MJ	1	1 5/8 - 12	48.0	1.88	104.5	4.11	46	1 13/16
N20-20MJ	1 1/4	1 5/8 - 12	50.5	1.98	117.0	4.60	46	1 13/16
N24-24MJ	1 1/2	1 7/8 - 12	57.0	2.24	139.5	5.49	50	2
N32-32MJ	2	2 1/2 - 12	68.5	2.69	165.0	6.49	65	2 9/16

FJ

JIC 37° FEMALE SWIVEL

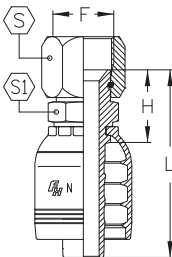

PART NUMBER	Hose Bore	F	H		L		S		S1	
	INCH		[mm]	[in]	[mm]	[in]	[mm]	[in]	[mm]	[in]
N06-06FJ	3/8	9/16 - 18	22.5	0.88	53.0	2.09	19	3/4	16	5/8
N06-08FJ	3/8	3/4 - 16	24.5	0.96	55.0	2.16	22	7/8	19	3/4
N08-06FJ	1/2	9/16 - 18	24.5	0.96	57.5	2.26	19	3/4	19	3/4
N08-08FJ	1/2	3/4 - 16	25.5	1.00	58.5	2.30	22	7/8	19	3/4
N08-10FJ	1/2	7/8 - 14	27.5	1.08	60.5	2.38	27	1 1/16	22	7/8
N08-12FJ	1/2	1 1/16 - 12	30.3	1.19	63.3	2.49	32	1 1/4	25	1
N10-10FJ	5/8	7/8 - 14	27.7	1.09	63.5	2.50	27	1 1/16	22	7/8
N10-12FJ	5/8	1 1/16 - 12	30.5	1.20	66.3	2.61	32	1 1/4	25	1
N12-10FJ	3/4	7/8 - 14	33.0	1.30	84.0	3.31	27	1 1/16	27	1 1/16
N12-12FJ	3/4	1 1/16 - 12	34.0	1.34	85.0	3.35	32	1 1/4	27	1 1/16
N12-14FJ	3/4	1 3/16 - 12	35.5	1.40	86.5	3.40	36	1 7/16	30	1 3/16
N12-16FJ	3/4	1 5/16 - 12	38.0	1.50	89.0	3.50	41	1 5/8	32	1 1/4
N16-12FJ	1	1 1/16 - 12	36.5	1.44	93.0	3.66	32	1 1/4	32	1 1/4
N16-16FJ	1	1 5/16 - 12	39.5	1.55	96.0	3.78	41	1 5/8	32	1 1/4
N16-20FJ	1	1 5/8 - 12	46.0	1.81	102.5	4.03	50	2	41	1 5/8
N20-16FJ	1 1/4	1 5/16 - 12	45.5	1.79	112.0	4.41	41	1 5/8	41	1 5/8
N20-20FJ	1 1/4	1 5/8 - 12	48.0	1.89	114.5	4.51	50	2	41	1 5/8
N20-24FJ	1 1/4	1 7/8 - 12	51.0	2.01	117.5	4.62	60	2 3/8	46	1 13/16
N24-24FJ	1 1/2	1 7/8 - 12	53.0	2.09	135.5	5.33	60	2 3/8	46	1 13/16
N32-32FJ	2	2 1/2 - 12	69.0	2.72	165.5	6.51	75	3	60	2 3/8

Reference Hose Section for Coupling Compatibility

COUPLINGS

FJ45 JIC 37° FEMALE SWIVEL - 45° ELBOW

PART NUMBER	Hose Bore	F	H		L		K		⊕	
	INCH		[mm]	[in]	[mm]	[in]	[mm]	[in]	[mm]	[in]
N06-06FJ45	3/8	9/16 - 18	35.5	1.40	66	2.60	12.0	0.47	19	3/4
N06-08FJ45	3/8	3/4 - 16	37.5	1.48	68	2.68	14.0	0.55	22	7/8
N08-08FJ45	1/2	3/4 - 16	41.0	1.61	74	2.91	14.5	0.57	22	7/8
N08-10FJ45	1/2	7/8 - 14	43.0	1.69	76	2.99	16.0	0.63	27	1 1/16
N08-12FJ45	1/2	1 1/16 - 12	45.5	1.79	78.5	3.09	19.0	0.75	32	1 1/4
N10-10FJ45	5/8	7/8 - 14	47.0	1.85	83	3.27	16.0	0.63	27	1 1/16
N10-12FJ45	5/8	1 1/16 - 12	50.0	1.97	86	3.38	19.0	0.75	32	1 1/4
N12-12FJ45	3/4	1 1/16 - 12	63.0	2.48	114	4.49	25.0	0.98	32	1 1/4
N12-16FJ45	3/4	1 5/16 - 12	63.0	2.48	114	4.49	25.0	0.98	41	1 5/8
N16-16FJ45	1	1 5/16 - 12	82.0	3.23	138	5.43	32.0	1.26	41	1 5/8
N16-20FJ45	1	1 5/8 - 12	82.0	3.23	138	5.43	32.0	1.26	50	2
N20-20FJ45	1 1/4	1 5/8 - 12	98.0	3.86	164	6.46	38.0	1.50	50	2
N20-24FJ45	1 1/4	1 7/8 - 12	98.0	3.86	164	6.46	38.0	1.50	60	2 3/8
N24-24FJ45	1 1/2	1 7/8 - 12	118.0	4.64	201	7.91	46.0	1.81	60	2 3/8
N32-32FJ45	2	2 1/2 - 12	157.0	6.18	253	9.96	62.0	2.44	75	3

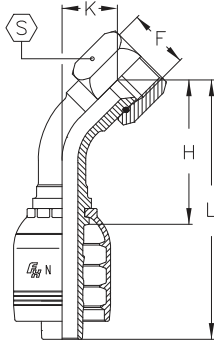

FJ90B BSP FEMALE 60° CONE - 90° COMPACT ELBOW

PART NUMBER	Hose Bore	F	H		L		K		⊕	
	INCH		[mm]	[in]	[mm]	[in]	[mm]	[in]	[mm]	[in]
N12-12FJ90B	3/4	1 1/16 - 12	36.0	1.42	80.6	3.17	30.5	1.20	32	1 1/4
N16-16FJ90B	1	1 5/16 - 12	32.0	1.26	87.0	3.43	33.5	1.32	35	1 1/2

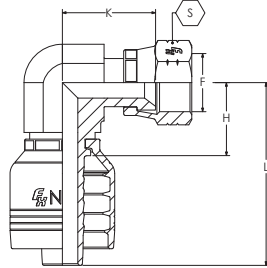

FJ90S JIC 37° FEMALE SWIVEL - 90° ELBOW SHORT DROP

PART NUMBER	Hose Bore	F	H		L		K		⊕	
	INCH		[mm]	[in]	[mm]	[in]	[mm]	[in]	[mm]	[in]
N06-06FJ90S	3/8	9/16 - 18	30	1.18	60.5	2.38	23	0.91	19	3/4
N06-08FJ90S	3/8	3/4 - 16	31	1.22	61.5	2.42	29	1.14	22	7/8
N08-08FJ90S	1/2	3/4 - 16	37	1.46	70	2.75	29	1.14	22	7/8
N08-10FJ90S	1/2	7/8 - 14	38	1.50	70	2.75	33	1.30	27	1 1/16
N08-12FJ90S	1/2	1 1/16 - 12	40	1.57	73	2.87	40	1.57	32	1 1/4
N10-10FJ90S	5/8	7/8 - 14	43	1.69	79	3.11	32	1.26	27	1 1/16
N10-12FJ90S	5/8	1 1/16 - 12	45	1.77	81	3.19	40	1.57	32	1 1/4

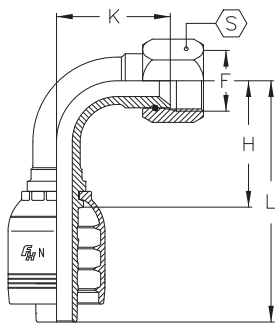

Reference Hose Section for Coupling Compatibility

COUPLINGS

FJ90M

JIC 37° FEMALE SWIVEL - 90° ELBOW MEDIUM DROP

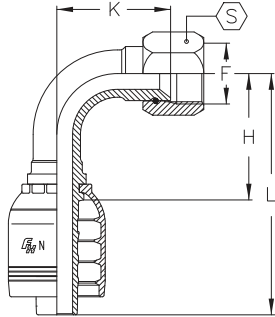

PART NUMBER	Hose Bore	F	H		L		K		S	
	INCH		[mm]	[in]	[mm]	[in]	[mm]	[in]	[mm]	[in]
N06-06FJ90M	3/8	9/16 - 18	31	1.22	61.5	2.42	33	1.30	19	3/4
N06-08FJ90M	3/8	3/4 - 16	31	1.22	61.5	2.42	33	1.30	22	7/8
N08-08FJ90M	1/2	3/4 - 16	37	1.46	70	2.75	39	1.54	22	7/8
N08-10FJ90M	1/2	7/8 - 14	37	1.46	70	2.75	40	1.57	27	1 1/16
N08-12FJ90M	1/2	1 1/16 - 12	37	1.46	70	2.75	45	1.77	32	1 1/4
N10-10FJ90M	5/8	7/8 - 14	45	1.77	81	3.19	45	1.77	27	1 1/16
N10-12FJ90M	5/8	1 1/16 - 12	45	1.77	81	3.19	47	1.85	32	1 1/4
N12-12FJ90M	3/4	1 1/16 - 12	55	2.16	106	4.17	52	2.05	32	1 1/4
N12-16FJ90M	3/4	1 5/16 - 12	55	2.16	106	4.17	56	2.20	36	1 7/16
N16-16FJ90M	1	1 5/16 - 12	71	2.79	128	5.04	67	2.64	41	1 5/8
N16-20FJ90M	1	1 5/8 - 12	71	2.79	128	5.04	69	2.72	50	2
N20-20FJ90M	1 1/4	1 5/8 - 12	87	3.42	154	6.06	81	3.19	50	2
N20-24FJ90M	1 1/4	1 7/8 - 12	87	3.42	154	6.06	82	3.23	60	2 3/8
N24-24FJ90M	1 1/2	1 7/8 - 12	105	4.13	188	7.40	97	3.82	60	2 3/8
N32-32FJ90M	2	2 1/2 - 12	140	5.51	237	9.33	132	5.20	75	3

FJ90L

JIC 37° FEMALE SWIVEL - 90° ELBOW LONG DROP

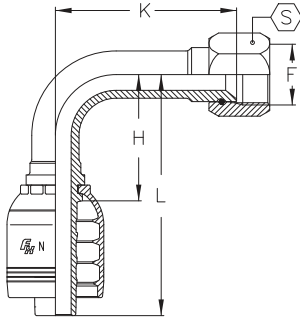

PART NUMBER	Hose Bore	F	H		L		K		S	
	INCH		[mm]	[in]	[mm]	[in]	[mm]	[in]	[mm]	[in]
N06-06FJ90L	3/8	9/16 - 18	31	1.22	61.5	2.42	54	2.12	19	3/4
N06-08FJ90L	3/8	1 1/16 - 12	38	1.50	71.0	2.79	64	2.52	22	7/8
N08-08FJ90L	3/8	1 1/16 - 12	38	1.50	71.0	2.79	64	2.52	22	7/8
N08-10FJ90L	1/2	7/8 - 14	38	1.50	71.0	2.79	70	2.75	27	1 1/16
N08-10FJ90L	1/2	7/8 - 14	38	1.50	71.0	2.79	70	2.75	27	1 1/16
N12-12FJ90L	3/4	1 1/16 - 12	55	2.16	106.0	4.17	96	3.78	32	1 1/4
N16-16FJ90L	1	1 5/16 - 12	71	2.79	128.0	5.04	116	4.57	41	1 5/8
N20-20FJ90L	1 1/4	1 5/8 - 12	87	3.42	154.0	6.06	136	5.35	50	2

MF

ORFS MALE

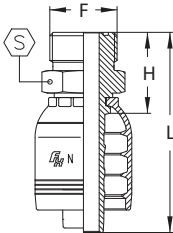

PART NUMBER	Hose Bore	F	H		L		S	
	INCH		[mm]	[in]	[mm]	[in]	[mm]	[in]
N06-06MF	3/8	1 1/16 - 16	25.5	1.00	56.0	2.20	19	3/4
N06-08MF	3/8	1 3/16 - 16	28.5	1.12	59.0	2.32	22	7/8
N08-08MF	1/2	1 3/16 - 16	29.5	1.16	62.5	2.46	22	7/8
N08-10MF	1/2	1 - 14	34.0	1.33	67.0	2.63	27	1 1/16
N08-12MF	1/2	1 3/16 - 12	37.0	1.45	70.0	2.75	32	1 1/4
N10-10MF	5/8	1 - 14	34.0	1.33	70.0	2.75	27	1 1/16
N10-12MF	5/8	1 3/16 - 12	37.0	1.45	73.0	2.87	32	1 1/4
N12-12MF	3/4	1 3/16 - 12	36.0	1.42	87.0	3.42	32	1 1/4
N16-16MF	1	1 7/16 - 12	41.0	1.61	97.0	3.82	41	1 5/8
N20-20MF	1 1/4	1 11/16 - 12	44.0	1.73	111.0	4.37	46	1 13/16
N24-24MF	1 1/2	1 7/8 - 12	48.0	1.89	131.0	5.16	55	2 1/4

Reference Hose Section for Coupling Compatibility

COUPLINGS

FF ORFS FEMALE SWIVEL

	PART NUMBER	Hose Bore	F	H		L		S		S1	
		INCH		[mm]	[in]	[mm]	[in]	[mm]	[in]	[mm]	[in]
	N06-06FF	3/8	1 1/16 - 16	28.5	1.12	59.0	2.32	22	7/8	16	5/8
	N06-08FF	3/8	1 3/16 - 16	32.5	1.27	63.0	2.48	24	1	19	3/4
	N08-06FF	1/2	1 1/16 - 16	30.5	1.20	63.5	2.50	22	7/8	19	3/4
	N08-08FF	1/2	1 3/16 - 16	33.5	1.31	66.5	2.61	24	1	19	3/4
	N08-10FF	1/2	1 - 14	39.5	1.55	72.5	2.85	30	1 3/16	24	1
	N08-12FF	1/2	1 3/16 - 12	43.5	1.71	76.5	3.01	36	1 7/16	27	1 1/16
	N10-10FF	5/8	1 - 14	39.5	1.55	75.5	2.97	30	1 3/16	24	1
	N10-12FF	5/8	1 3/16 - 12	43.5	1.71	79.5	3.12	36	1 7/16	27	1 1/16
	N12-10FF	3/4	1 - 14	43.0	1.69	94.0	3.70	30	1 3/16	27	1/16
	N12-12FF	3/4	1 3/16 - 12	46.0	1.81	97.0	3.82	36	1 7/16	30	1 3/16
	N12-16FF	3/4	1 7/16 - 12	49.0	1.93	100.0	3.94	41	1 5/8	36	1 7/16
	N16-16FF	1	1 7/16 - 12	51.0	2.01	107.0	4.21	41	1 5/8	36	1 7/16
	N16-20FF	1	1 11/16 - 12	52.0	2.05	109.0	4.29	50	2	41	1 5/8
	N20-20FF	1 1/4	1 11/16 - 12	55.0	2.16	121.0	4.76	50	2	41	1 5/8
N24-24FF	1 1/2	2 - 12	60.0	2.36	142.0	5.59	60	2 3/8	50	2	

FF45 ORFS FEMALE SWIVEL - 45° ELBOW

	PART NUMBER	Hose Bore	F	H		L		K		S	
		INCH		[mm]	[in]	[mm]	[in]	[mm]	[in]	[mm]	[in]
	N06-06FF45	3/8	1 1/16 - 16	36.0	1.41	66.5	2.61	12.5	0.49	22	7/8
	N06-08FF45	3/8	1 3/16 - 16	38.5	1.51	69.0	2.71	15.0	0.59	24	1
	N08-08FF45	1/2	1 3/16 - 16	42.5	1.67	75.5	2.97	15.5	0.61	24	1
	N08-10FF45	1/2	1 - 14	45.0	1.77	78.0	3.07	17.5	0.68	30	1 3/16
	N08-12FF45	1/2	1 3/16 - 12	47.0	1.85	80.0	3.14	20.5	0.80	36	1 7/16
	N10-10FF45	5/8	1 - 14	49.0	1.92	85.0	3.34	18.0	0.70	30	1 3/16
	N10-12FF45	5/8	1 3/16 - 12	51.5	2.02	87.5	3.44	20.5	0.80	36	1 7/16
	N12-12FF45	3/4	1 3/16 - 12	60.0	2.36	111.0	4.37	22.0	0.87	36	1 7/16
	N16-16FF45	1	1 7/16 - 12	78.0	3.07	134.0	5.27	29.0	1.14	41	1 5/8
	N16-20FF45	1	1 11/16 - 12	78.0	3.07	134.0	5.27	29.0	1.14	50	2
	N20-20FF45	1 1/4	1 11/16 - 12	93.0	3.66	159.0	6.26	34.0	1.34	50	2
	N24-24FF45	1 1/2	2 - 12	113.0	4.45	195.0	7.68	41.0	1.61	60	2 1/2

Reference Hose Section for Coupling Compatibility

www.**FLETRAL**.com

COUPLINGS

FF90S ORFS FEMALE SWIVEL - 90° ELBOW SHORT DROP

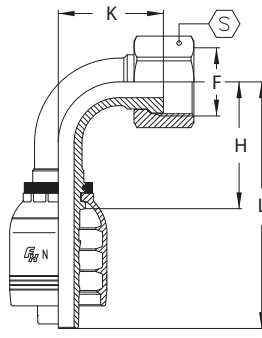

PART NUMBER	Hose Bore	F	H		L		K		S	
	INCH		[mm]	[in]	[mm]	[in]	[mm]	[in]	[mm]	[in]
N06-06FF90S	3/8	1 1/16 - 16	31.5	1.24	62.0	2.44	24.5	0.96	22	7/8
N06-08FF90S	3/8	1 3/16 - 16	31.0	1.22	61.0	2.40	30.0	1.18	24	1
N08-08FF90S	1/2	1 3/16 - 16	39.0	1.54	72.0	2.83	31.0	1.22	24	1
N08-10FF90S	1/2	1 - 14	39.0	1.54	72.0	2.83	34.0	1.34	30	1 3/16
N08-12FF90S	1/2	1 3/16 - 12	39.0	1.54	72.0	2.83	42.0	1.65	36	1 7/16
N10-10FF90S	5/8	1 - 14	45.0	1.77	81.0	3.19	35.0	1.38	30	1 3/16
N10-12FF90S	5/8	1 3/16 - 12	45.0	1.77	81.0	3.19	42.0	1.65	36	1 7/16
N12-12FF90S	3/4	1 3/16 - 12	54.0	2.13	105.0	4.13	48.0	1.89	36	1 7/16
N12-16FF90S	3/4	1 7/16 - 12	54.0	2.13	105.0	4.13	49.0	1.93	41	1 5/8
N16-16FF90S	1	1 7/16 - 12	71.0	2.79	127.0	5.00	62.0	2.44	41	1 5/8
N16-20FF90S	1	1 11/16 - 12	71.0	2.79	127.0	5.00	62.0	2.44	50	2
N20-20FF90M	1 1/4	1 11/16 - 12	87	3.42	153	6.02	75	2.95	50	2
N24-24FF90M	1 1/2	2 - 12	105	4.13	187	7.36	90	3.54	60	2 3/8

FF90L ORFS FEMALE SWIVEL - 90° ELBOW LONG DROP

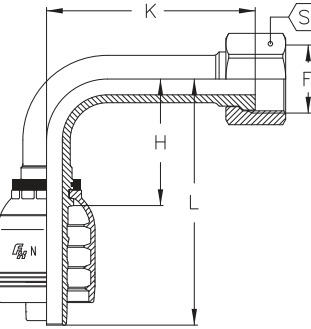

PART NUMBER	Hose Bore	F	H		L		K		S	
	INCH		[mm]	[in]	[mm]	[in]	[mm]	[in]	[mm]	[in]
N06-06FF90L	3/8	1 1/16 - 16	34.0	1.33	64.5	2.53	54.0	2.12	22	7/8
N08-08FF90L	1/2	1 3/16 - 16	39.0	1.53	72.0	2.83	64.0	2.51	24	1
N08-10FF90L	1/2	1 - 14	39.0	1.53	72.0	2.83	64.0	2.51	30	1 3/16
N10-10FF90L	5/8	1 - 14	45.0	1.77	81.0	3.18	70.0	2.75	30	1 3/16
N12-12FF90L	3/4	1 3/16 - 12	54.0	2.13	105.0	4.13	96.0	3.78	36	1 7/16
N16-16FF90L	1	1 7/16 - 12	71.0	2.79	127.0	5.00	114.0	4.49	41	1 5/8
N20-20FF90L	1 1/4	1 11/16 - 12	87.0	3.42	153.0	6.02	130.0	5.12	50	2
N24-24FF90L	1 1/2	2 - 12	105.0	4.13	187.0	7.36	155.0	6.10	60	2 1/2

MOB O-RING BOSS MALE

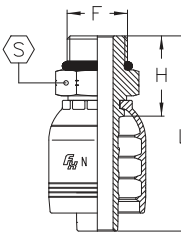

PART NUMBER	Hose Bore	F	H		L		S	
	INCH		[mm]	[in]	[mm]	[in]	[mm]	[in]
N06-06MOB	3/8	9/16 - 18	23.5	0.92	54.0	2.12	17	1 1/16
N08-08MOB	1/2	3/4 - 16	27.2	1.07	60.2	2.37	22	7/8

Reference Hose Section for Coupling Compatibility

COUPLINGS

FJIS JIS FEMALE SWIVEL (TOYOTA)

PART NUMBER	Hose Bore	F	H		L		S		S1	
	INCH		[mm]	[in]	[mm]	[in]	[mm]	[in]	[mm]	[in]
	N06-06FJIS		3/8	3/8 - 19	26	1.02	57	2.24	22	7/8
N08-08FJIS	1/2	1/2 - 14	30	1.18	63	2.48	27	11/16	22	7/8
N12-12FJIS	3/4	3/4 - 14	32	1.26	83	3.27	32	15/8	27	11/16
N16-16FJIS	1	1 - 11	37	1.46	93.5	3.68	41	2	36	17/16
N20-20FJIS	1 1/4	1 1/4 - 11	44	1.73	110.5	4.35	50	2 3/16	41	1 5/8
N24-24FJIS	1 1/2	1 1/2 - 11	48.5	1.91	131	5.16	55	2 3/8	50	1 15/16

FK KOMATSU FEMALE SWIVEL

PART NUMBER	Hose Bore	F	H		L		S		S1	
	INCH		[mm]	[in]	[mm]	[in]	[mm]	[in]	[mm]	[in]
	N06-18FK		3/8	M18 x 1.5	24.3	0.95	54.8	2.15	24	1
N06-20FK	3/8	M20 x 1.5	29.0	1.14	59.0	2.32	25	1	22	7/8
N06-22FK	3/8	M22 x 1.5	29.0	1.14	59.0	2.32	27	1 1/16	22	7/8
N08-18FK	1/2	M18 x 1.5	26.0	1.02	59.0	2.32	24	1	22	7/8
N08-22FK	1/2	M22 x 1.5	26.5	1.04	59.5	2.34	27	1 1/16	27	1 1/16
N08-24FK	1/2	M24 x 1.5	29.9	1.17	62.9	2.47	32	1 1/4	32	1 1/4
N10-24FK	5/8	M24 x 1.5	29.9	1.17	65.9	2.59	32	1 1/4	32	1 1/4
N12-24FK	3/4	M24 x 1.5	33.0	1.30	84.0	3.31	32	1 1/4	32	1 1/4
N12-30FK	3/4	M30 x 1.5	36.0	1.42	87.0	3.43	36	1 7/16	36	1 7/16
N16-33FK	1	M33 x 1.5	38.0	1.50	95.0	3.74	41	1 5/8	36	1 7/16
N16-36FK	1	M36 x 1.5	42.0	1.65	98.0	3.86	46	1 13/16	41	1 5/8
N20-36FK	1 1/4	M36 x 1.5	44.0	1.73	110.5	4.35	46	1 13/16	41	1 5/8
N24-42FK	1 1/2	M42 x 1.5	49.0	1.93	131.0	5.16	50	2	50	2

FLK KOMATSU FLANGE

PART NUMBER	Hose Bore	FLANGE	A		H		L	
	INCH		[mm]	[in]	[mm]	[in]	[mm]	[in]
	N08-10FLK		1/2	34mm x .265	34	1.33	49.3	1.94
N10-10FLK	5/8	34mm x .265	34	1.33	49.3	1.94	85.3	3.35

Reference Hose Section for Coupling Compatibility

COUPLINGS

FLK45 KOMATSU FLANGE - 45° ELBOW

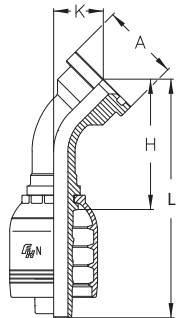

PART NUMBER	Hose Bore	FLANGE	A		H		L		K	
	INCH		[mm]	[in]	[mm]	[in]	[mm]	[in]	[mm]	[in]
N08-10FLK45	1/2	34mm x .265	34	1.33	71	2.79	104	4.09	27.5	1.08
N10-10FLK45	5/8	34mm x .265	34	1.33	70	2.75	110	4.33	30.0	1.18

FLK90 KOMATSU FLANGE - 90° ELBOW

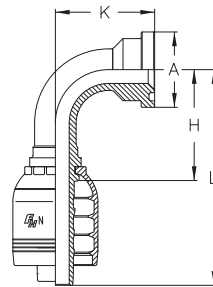

PART NUMBER	Hose Bore	FLANGE	A		H		L		K	
	INCH		[mm]	[in]	[mm]	[in]	[mm]	[in]	[mm]	[in]
N08-10FLK90-044	1/2	34mm x .265	34	1.33	41	1.61	74	2.91	44	1.73
N10-10FLK90-049	5/8	34mm x .265	34	1.33	49	1.92	85	3.34	49	1.92

MKBC KOBELCO MALE

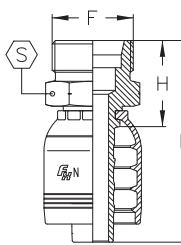

PART NUMBER	Hose Bore	F	H		L		S	
	INCH		[mm]	[in]	[mm]	[in]	[mm]	[in]
N12-30MKBC	3/4	M30 x 1.5	39.2	1.54	90.2	3.55	38	1.50
N12-36MKBC	3/4	M36 x 1.5	39.2	1.54	90.2	3.55	41	1.61
N16-36MKBC	1	M36 x 1.5	42.5	1.67	99.0	3.90	41	1.61
N16-45MKBC	1	M45 x 1.5	45.0	1.77	101.6	4.00	50	1.97

MBSPT BSPT MALE

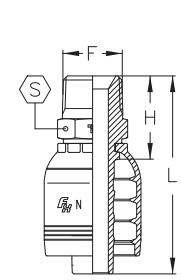

PART NUMBER	Hose Bore	F	H		L		S	
	INCH		[mm]	[in]	[mm]	[in]	[mm]	[in]
N06-06MBSPT	3/8	3/8 - 19	27	1.06	57	2.24	19	3/4
N08-08MBSPT	1/2	1/2 - 14	33	1.30	66	2.60	22	7/8
N12-12MBSPT	3/4	3/4 - 14	37	1.46	88	3.46	27	1 1/16
N16-16MBSPT	1	1 - 11	44	1.73	101	3.98	36	1 7/16
N20-20MBSPT	1 1/4	1 1/4 - 11	51	2.01	118	4.64	46	1 13/16
N24-24MBSPT	1 1/2	1 1/2 - 11	54	2.12	137	5.39	50	2
N32-32MBSPT	2	2 - 11	64	2.52	160	6.30	65	2 9/16

Reference Hose Section for Coupling Compatibility

COUPLINGS

MBSPP BSPP MALE

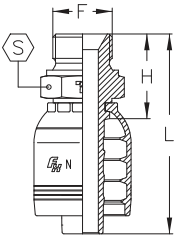

PART NUMBER	Hose Bore	F	H		L		S	
	INCH		[mm]	[in]	[mm]	[in]	[mm]	[in]
N06-06MBSPP	3/8	3/8 - 19	27	1.06	58	2.28	22	7/8
N06-08MBSPP	3/8	1/2 - 14	32	1.25	62	2.44	27	1 1/16
N08-08MBSPP	1/2	1/2 - 14	28	1.10	67	2.63	22	7/8
N10-10MBSPP	5/8	5/8 - 14	35	1.37	71	2.79	30	1 3/16
N10-12MBSPP	5/8	3/4 - 14	36	1.41	72	2.83	32	1 1/4
N12-12MBSPP	3/4	3/4 - 14	38	1.50	89	3.50	32	1 1/4
N16-16MBSPP	1	1 - 11	45	1.77	101	3.98	41	1 5/8
N16-20MBSPP	1	1 1/4 - 11	48	1.89	104	4.09	50	2
N20-20MBSPP	1 1/4	1 1/4 - 11	50	1.97	117	4.61	50	2
N24-24MBSPP	1 1/2	1 1/2 - 11	55	2.16	138	5.43	55	2 1/4
N32-32MBSPP	2	2 - 11	63	2.48	159	6.26	70	2 3/4

FBSP BSPP FEMALE SWIVEL

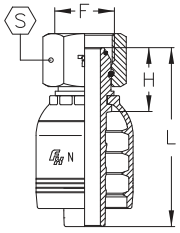

PART NUMBER	Hose Bore	F	H		L		S	
	INCH		[mm]	[in]	[mm]	[in]	[mm]	[in]
N06-06FBSP	3/8	3/8 - 19	21	0.83	51	2.01	22	7/8
N06-08FBSP	3/8	1/2 - 14	23	0.90	54	2.12	27	1 1/16
N08-08FBSP	1/2	1/2 - 14	23	0.90	56	2.20	27	1 1/16
N08-10FBSP	1/2	5/8 - 14	24	0.94	57	2.24	30	1 3/16
N10-10FBSP	5/8	5/8 - 14	23	0.90	59	2.32	30	1 3/16
N10-12FBSP	5/8	3/4 - 14	27	1.06	63	2.48	32	1 1/4
N12-12FBSP	3/4	3/4 - 14	29	1.14	80	3.15	32	1 1/4
N12-16FBSP	3/4	1 - 11	32	1.26	83	3.27	41	1 5/8
N16-16FBSP	1	1 - 11	34	1.34	90	3.54	41	1 5/8
N16-20FBSP	1	1 1/4 - 11	37	1.46	93	3.66	50	2
N20-20FBSP	1 1/4	1 1/4 - 11	39	1.53	106	4.17	50	2
N24-24FBSP	1 1/2	1 1/2 - 11	43	1.69	125	4.92	60	2 1/2
N32-32FBSP	2	2 - 11	47	1.85	143	5.63	75	3

FBSP45 BSPP FEMALE SWIVEL - 45° ELBOW

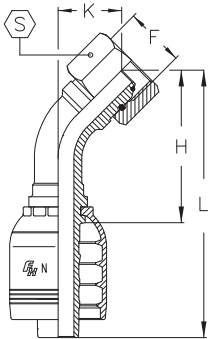

PART NUMBER	Hose Bore	F	H		L		K		S	
	INCH		[mm]	[in]	[mm]	[in]	[mm]	[in]	[mm]	[in]
N06-06FBSP45	3/8	3/8 - 19	42	1.65	73	2.87	19	0.75	22	7/8
N08-08FBSP45	1/2	1/2 - 14	49	1.93	82	3.23	22	0.86	27	1 1/16
N10-10FBSP45	5/8	5/8 - 14	54	2.12	90	3.54	24	0.94	30	1 3/16
N10-12FBSP45	5/8	3/4 - 14	57	2.24	93	3.66	26	1.02	32	1 1/4
N12-12FBSP45	3/4	3/4 - 14	67	2.64	118	4.64	29	1.14	32	1 1/4
N12-16FBSP45	3/4	1 - 11	67	2.64	118	4.64	29	1.14	41	1 5/8
N16-16FBSP45	1	1 - 11	86	3.38	142	5.59	36	1.41	41	1 5/8
N16-20FBSP45	1	1 1/4 - 11	86	3.38	142	5.59	36	1.41	50	2
N20-20FBSP45	1 1/4	1 1/4 - 11	103	4.05	169	6.65	43	1.69	50	2
N24-24FBSP45	1 1/2	1 1/2 - 11	123	4.84	206	8.11	51	2.01	60	2 1/2
N32-32FBSP45	2	2 - 11	160	6.30	257	10.11	65	2.56	75	3

Reference Hose Section for Coupling Compatibility

COUPLINGS

FBSP90 BSPP FEMALE SWIVEL - 90° ELBOW

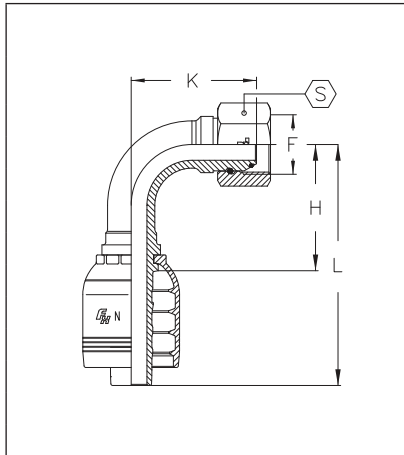

PART NUMBER	Hose Bore	F	H		L		K		S	
	INCH		[mm]	[in]	[mm]	[in]	[mm]	[in]	[mm]	[in]
N06-06FBSP90	3/8	3/8 - 19	31	1.22	61	2.40	35	1.38	22	7/8
N08-08FBSP90	1/2	1/2 - 14	37	1.46	70	2.75	42	1.65	27	1 1/16
N10-10FBSP90	5/8	5/8 - 14	45	1.77	80	3.15	46	1.81	30	1 3/16
N10-12FBSP90	5/8	3/4 - 14	45	1.77	80	3.15	50	1.97	32	1 1/4
N12-12FBSP90	3/4	3/4 - 14	55	2.16	106	4.17	57	2.24	32	1 1/4
N12-16FBSP90	3/4	1 - 11	55	2.16	106	4.17	57	2.24	41	1 5/8
N16-16FBSP90	1	1 - 11	71	2.79	128	5.04	72	2.83	41	1 5/8
N16-20FBSP90	1	1 1/4 - 11	71	2.79	128	5.04	72	2.83	50	2
N20-20FBSP90	1 1/4	1 1/4 - 11	87	3.42	154	6.06	88	3.46	50	2
N24-24FBSP90	1 1/2	1 1/2 - 11	105	4.13	188	7.40	104	4.09	60	2 1/2
N32-32FBSP90	2	2 - 11	140	5.51	237	9.33	137	5.39	75	3

MML MALE METRIC LIGHT (24° SEAT) - CEL

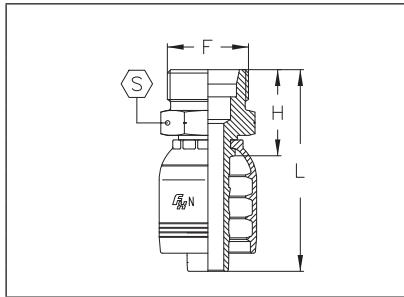

PART NUMBER	Hose Bore	F	Tube	H		L		S	
	INCH			[mm]	[in]	[mm]	[in]	[mm]	[in]
N06-18MML	3/8	M18 x 1.5	L12	23	0.90	53	2.08	19	3/4
N08-22MML	1/2	M22 x 1.5	L15	26	1.02	59	2.32	22	7/8
N10-26MML	5/8	M26 x 1.5	L18	28	1.10	64	2.51	27	1 1/16
N12-30MML	3/4	M30 x 2.0	L22	32	1.26	83	3.27	30	1 3/16
N16-36MML	1	M36 x 2.0	L28	36	1.42	93	3.66	36	1 7/16
N20-45MML	1 1/4	M45 x 2.0	L35	43	1.69	109	4.29	46	1 13/16

FML FEMALE SWIVEL METRIC LIGHT (24° SEAT) - DKOL

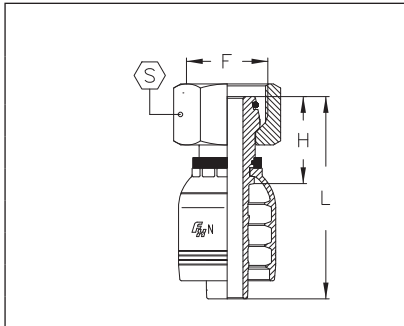

PART NUMBER	Hose Bore	F	Tube	H		L		S	
	INCH			[mm]	[in]	[mm]	[in]	[mm]	[in]
N06-18FML	3/8	M18 x 1.5	L12	24	0.94	54	2.12	22	7/8
N08-22FML	1/2	M22 x 1.5	L15	24	0.94	57	2.24	27	1 1/16
N10-26FML	5/8	M26 x 1.5	L18	27	1.06	62	2.44	32	1 1/4
N12-30FML	3/4	M30 x 2.0	L22	31	1.22	82	3.23	36	1 7/16
N16-36FML	1	M36 x 2.0	L28	34	1.34	90	3.54	41	1 5/8
N20-45FML	1 1/4	M45 x 2.0	L35	39	1.54	106	4.17	50	2
N24-52FML	1 1/2	M52 x 2.0	L42	43	1.69	126	4.96	60	2 1/2

Reference Hose Section for Coupling Compatibility

COUPLINGS

FML45 FEMALE METRIC LIGHT SWIVEL - 45° ELBOW (24° SEAT) - DKOL

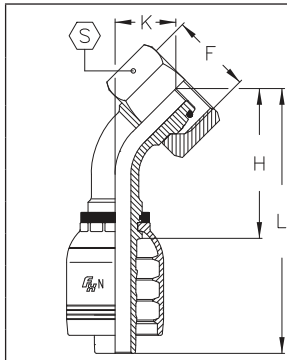

PART NUMBER	Hose Bore	F	Tube	H		L		K		S	
	INCH			[mm]	[in]	[mm]	[in]	[mm]	[in]	[mm]	[in]
N06-18FML45	3/8	M18 x 1.5	L12	40	1.22	71	2.80	18	.71	22	7/8
N08-22FML45	1/2	M22 x 1.5	L15	46	1.81	79	3.11	19	0.74	27	1 1/16
N10-26FML45	5/8	M26 x 1.5	L18	53	2.08	89	3.50	22	0.86	32	1 1/4
N12-30FML45	3/4	M30 x 2.0	L22	64	2.52	115	4.53	25	0.98	36	1 7/16
N16-36FML45	1	M36 x 2.0	L28	82	3.23	139	5.47	31	1.22	41	1 5/8
N20-45FML45	1 1/4	M45 x 2.0	L35	101	3.98	168	6.61	40	1.57	50	2

FML90 FEMALE METRIC LIGHT SWIVEL - 90° ELBOW (24° SEAT) - DKOL

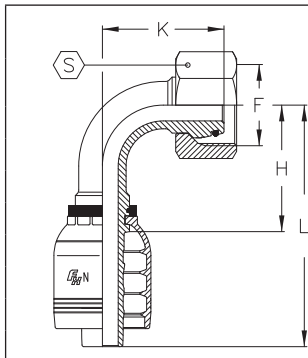

PART NUMBER	Hose Bore	F	Tube	H		L		K		S	
	INCH			[mm]	[in]	[mm]	[in]	[mm]	[in]	[mm]	[in]
N06-18FML90	3/8	M18 x 1.5	L12	31	1.22	61	2.40	33	1.30	22	7/8
N08-22FML90	1/2	M22 x 1.5	L15	37	1.45	70	2.75	38	1.49	27	1 1/16
N10-26FML90	5/8	M26 x 1.5	L18	44	1.73	80	3.14	45	1.77	32	1 1/4
N12-30FML90	3/4	M30 x 2.0	L22	57	2.24	108	4.25	52	2.05	36	1 7/16
N16-36FML90	1	M36 x 2.0	L28	73	2.87	130	5.12	66	2.60	41	1 5/8
N20-45FML90	1 1/4	M45 x 23.0	L35	90	3.54	157	6.18	83	3.27	50	2

MMS MALE METRIC HEAVY (24° SEAT) - CES

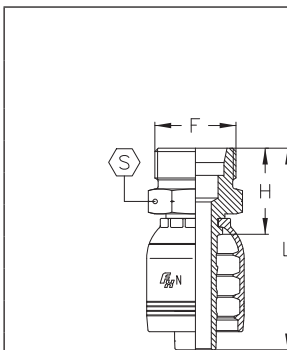

PART NUMBER	Hose Bore	F	Tube	H		L		S	
	INCH			[mm]	[in]	[mm]	[in]	[mm]	[in]
N06-20MMS	3/8	M20 x 1.5	S12	25	0.98	56	2.20	22	7/8
N06-22MMS	3/8	M22 x 1.5	S14	27	1.06	58	2.28	22	7/8
N08-24MMS	1/2	M24 x 1.5	S16	29	1.14	62	2.44	24	1
N10-30MMS	5/8	M30 x 2.0	S20	32	1.26	68	2.68	30	1 3/16
N12-30MMS	3/4	M30 x 2.0	S20	34	1.34	85	3.35	30	1 3/16
N12-36MMS	3/4	M36 x 2.0	S25	38	1.50	89	3.50	36	1 7/16
N16-36MMS	1	M36 x 2.0	S25	40	1.57	97	3.82	36	1 7/16
N16-42MMS	1	M42 x 2.0	S30	44	1.73	101	3.98	46	1 13/16
N20-42MMS	1 1/4	M42 x 2.0	S30	47	1.85	113	4.45	46	1 13/16
N20-52MMS	1 1/4	M52 x 2.0	S38	51	2.01	117	4.61	55	2 1/4
N24-52MMS	1 1/2	M52 x 2.0	S38	53	2.09	135	5.31	55	2 1/4

Reference Hose Section for Coupling Compatibility

COUPLINGS

FMS FEMALE METRIC HEAVY SWIVEL (24° SEAT) - DKOS

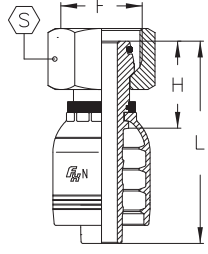

PART NUMBER	Hose Bore	F	Tube	H		L		S	
	INCH			[mm]	[in]	[mm]	[in]	[mm]	[in]
N06-18FMS	3/8	M18 x 1.5	S10	25	0.98	55	2.16	22	7/8
N06-20FMS	3/8	M20 x 1.5	S12	24	0.94	54	2.12	24	1
N06-22FMS	3/8	M22 x 1.5	S14	28	1.10	58	2.28	27	1 1/16
N08-22FMS	1/2	M22 x 1.5	S14	28	1.10	61	2.40	27	1 1/16
N08-24FMS	1/2	M24 x 1.5	S16	29	1.14	62	2.44	30	1 3/16
N10-30FMS	5/8	M30 x 2.0	S20	33	1.30	69	2.72	36	1 7/16
N12-30FMS	3/4	M30 x 2.0	S20	37	1.46	88	3.46	36	1 7/16
N12-36FMS	3/4	M36 x 2.0	S25	39	1.53	90	3.54	46	1 13/16
N16-36FMS	1	M36 x 2.0	S25	41	1.61	97	3.82	46	1 13/16
N16-42FMS	1	M42 x 2.0	S30	42	1.65	98	3.86	50	2
N20-42FMS	1 1/4	M42 x 2.0	S30	43	1.69	109	4.29	50	2
N20-52FMS	1 1/4	M52 x 2.0	S38	48	1.89	115	4.53	60	2 1/2
N24-52FMS	1 1/2	M52 x 2.0	S38	51	2.01	133	5.24	60	2 1/2

FMS45 FEMALE METRIC HEAVY SWIVEL - 45° ELBOW (24° SEAT) - DKOS

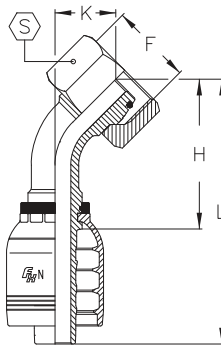

PART NUMBER	Hose Bore	F	Tube	H		L		K		S	
	INCH			[mm]	[in]	[mm]	[in]	[mm]	[in]	[mm]	[in]
N06-20FMS45	3/8	M20 x 1.5	S12	40	1.57	71	2.79	18	0.71	24	1
N06-22FMS45	3/8	M22 x 1.5	S14	42	1.65	72	2.83	19	0.75	27	1 1/16
N08-22FMS45	1/2	M22 x 1.5	S14	46	1.81	79	3.11	20	0.78	27	1 1/16
N08-24FMS45	1/2	M24 x 1.5	S16	47	1.85	80	3.15	21	0.83	30	1 3/16
N10-30FMS45	5/8	M30 x 2.0	S20	56	2.20	92	3.62	25	0.98	36	1 7/16
N12-30FMS45	3/4	M30 x 2.0	S20	65	2.56	116	4.57	27	1.06	36	1 7/16
N12-36FMS45	3/4	M36 x 2.0	S25	66	2.60	117	4.61	28	1.10	46	1 13/16
N16-36FMS45	1	M36 x 2.0	S25	83	3.27	140	5.51	34	1.34	46	1 13/16
N16-42FMS45	1	M42 x 2.0	S30	82	3.23	138	5.43	32	1.26	50	2
N20-42FMS45	1 1/4	M42 x 2.0	S30	100	3.94	166	6.53	40	1.57	50	2
N20-52FMS45	1 1/4	M52 x 2.0	S38	97	3.82	164	6.46	38	1.50	60	2 1/2
N24-52FMS45	1 1/2	M52 x 2.0	S38	121	4.76	203	7.99	48	1.89	60	2 1/2

Reference Hose Section for Coupling Compatibility

COUPLINGS

FMS90

FEMALE METRIC HEAVY SWIVEL - 90° ELBOW (24° SEAT) - DKOS

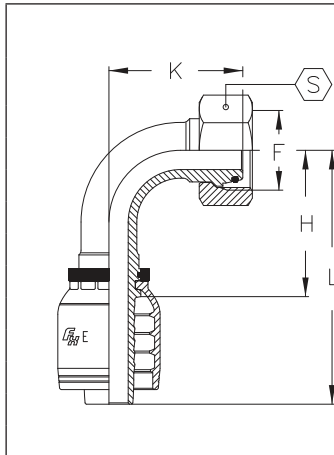

PART NUMBER	Hose Bore	F	Tube	H		L		K		S	
	INCH			[mm]	[in]	[mm]	[in]	[mm]	[in]	[mm]	[in]
N06-20FMS90	3/8	M20 x 1.5	S12	31	1.22	61	2.40	33	1.30	24	1
N06-22FMS90	3/8	M22 x 1.5	S14	34	1.34	64	2.52	37	1.46	27	1 1/16
N08-24FMS90	1/2	M24 x 1.5	S16	39	1.53	71	2.79	42	1.65	30	1 3/16
N10-30FMS90	5/8	M30 x 2.0	S20	44	1.73	80	3.15	49	1.93	36	1 7/16
N12-30FMS90	3/4	M30 x 2.0	S20	55	2.16	106	4.17	55	2.16	36	1 7/16
N12-36FMS90	3/4	M36 x 2.0	S25	55	2.16	106	4.17	55	2.16	46	1 13/16
N16-36FMS90	1	M36 x 2.0	S25	71	2.79	128	5.04	69	2.72	46	1 13/16
N16-42FMS90	1	M42 x 2.0	S30	71	2.79	128	5.04	67	2.64	50	2
N20-42FMS90	1 1/4	M42 x 2.0	S30	87	3.42	154	6.06	83	3.27	50	2
N20-52FMS90	1 1/4	M52 x 2.0	S38	87	3.42	154	6.06	80	3.15	60	2 1/2
N24-52FMS90	1 1/2	M52 x 2.0	S38	105	4.13	188	7.40	100	3.94	60	2 1/2

FL

SAE CODE 61 FLANGE

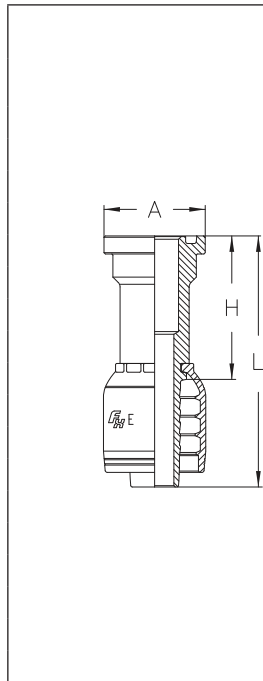

PART NUMBER	Hose Bore	FLANGE Thickness	A		H		L	
	INCH		[mm]	[in]	[mm]	[in]	[mm]	[in]
N08-08FL	1/2	0.265	30.2	1.19	48.5	1.91	61.5	2.42
N08-12FL	1/2	0.265	38.1	1.50	52.5	2.07	85.5	3.37
N10-12FL	5/8	0.265	38.1	1.50	52.5	2.07	88.5	3.48
N12-12FL	3/4	0.265	38.1	1.50	55.0	2.16	106.0	4.17
N12-16FL	3/4	0.315	44.5	1.75	57.0	2.24	108.0	4.25
N12-20FL	3/4	0.315	50.8	2.00	55.0	2.16	106.0	4.17
N16-12FL	1	0.265	38.1	1.50	58.0	2.28	114.5	4.51
N16-16FL	1	0.315	44.5	1.75	58.0	2.28	114.5	4.51
N16-20FL	1	0.315	50.8	2.00	63.0	2.48	119.5	4.70
N16-24FL	1	0.315	60.4	2.38	55.0	2.16	115.5	4.55
N20-16FL	1 1/4	0.315	44.5	1.75	64.0	2.52	130.5	5.14
N20-20FL	1 1/4	0.315	50.8	2.00	64.0	2.52	130.5	5.14
N20-24FL	1 1/4	0.315	60.4	2.38	68.0	2.68	134.5	5.29
N20-32FL	1 1/4	0.375	71.4	2.81	75.0	2.95	141.5	5.57
N24-24FL	1 1/2	0.315	60.4	2.38	73.0	2.87	155.5	6.12
N24-32FL	1 1/2	0.375	71.4	2.81	76.0	2.99	158.5	6.24
N32-32FL	2	0.375	71.4	2.81	77.0	3.03	176.5	6.95
N32-40FL	2	0.375	84.1	3.31	90.0	3.54	186.5	7.34

Reference Hose Section for Coupling Compatibility

COUPLINGS

FL22

SAE CODE 61 FLANGE - 22.5° ELBOW

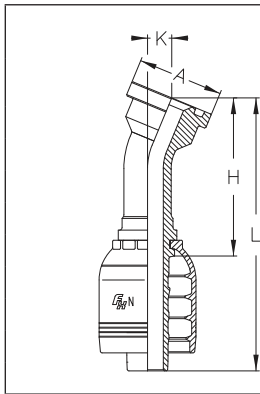

PART NUMBER	Hose Bore	FLANGE Thickness	A		H		L		K	
	INCH		[mm]	[in]	[mm]	[in]	[mm]	[in]	[mm]	[in]
N12-12FL22	3/4	0.265	38.1	1.50	70	2.75	121	4.76	11	0.43
N12-16FL22	3/4	0.315	44.5	1.75	73	2.87	124	4.88	12	0.47
N16-16FL22	1	0.315	44.5	1.75	86	3.38	142	5.59	12	0.47
N16-20FL22	1	0.315	50.8	2.00	86	3.38	142	5.59	12	0.47
N20-20FL22	1 1/4	0.315	50.8	2.00	100	3.94	166	6.53	13	0.51
N20-24FL22	1 1/4	0.315	60.4	2.38	100	3.94	166	6.53	13	0.51
N24-24FL22	1 1/2	0.315	60.4	2.38	118	4.64	201	7.91	15	0.59
N24-32FL22	1 1/2	0.375	71.4	2.81	116	4.57	199	7.83	14	0.55
N32-32FL22	2	0.375	71.4	2.81	165	6.50	262	10.31	22	0.86

FL30

SAE CODE 61 FLANGE - 30° ELBOW

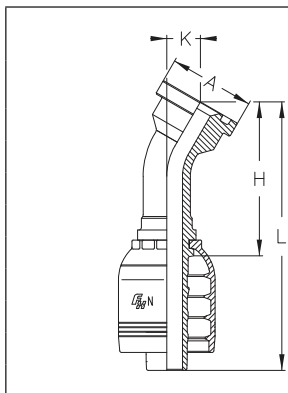

PART NUMBER	Hose Bore	FLANGE Thickness	A		H		L		K	
	INCH		[mm]	[in]	[mm]	[in]	[mm]	[in]	[mm]	[in]
N12-12FL30	3/4	0.265	38.1	1.50	68	2.68	119	4.68	16	0.63
N12-16FL30	3/4	0.315	44.5	1.75	71	2.79	122	4.80	17	0.67
N16-16FL30	1	0.315	44.5	1.75	84	3.31	140	5.51	17	0.67
N16-20FL30	1	0.315	50.8	2.00	84	3.31	140	5.51	17	0.67
N20-20FL30	1 1/4	0.315	50.8	2.00	98	3.86	164	6.46	19	0.75
N20-24FL30	1 1/4	0.315	60.4	2.38	98	3.86	164	6.46	19	0.75
N24-24FL30	1 1/2	0.315	60.4	2.38	116	4.57	199	7.83	22	0.87
N24-32FL30	1 1/2	0.375	71.4	2.81	114	4.49	197	7.75	21	0.83
N32-32FL30	2	0.375	71.4	2.81	162	6.38	258	10.16	31	1.22

FL45

SAE CODE 61 FLANGE - 45° ELBOW

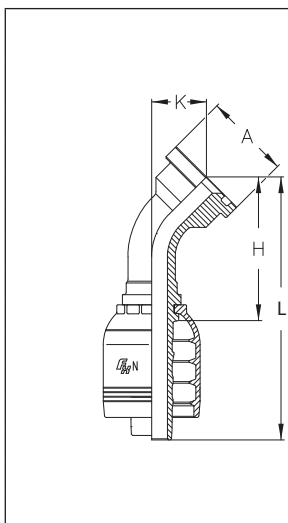

PART NUMBER	Hose Bore	FLANGE Thickness	A		H		L		K	
	INCH		[mm]	[in]	[mm]	[in]	[mm]	[in]	[mm]	[in]
N08-08FL45	1/2	0.265	30.2	1.19	62.0	2.44	95.0	3.74	22.5	0.89
N08-12FL45	1/2	0.265	38.1	1.50	66.0	2.60	99.0	3.90	27.0	1.06
N10-12FL45	5/8	0.265	38.1	1.50	79.5	3.13	115.5	4.55	27.5	1.08
N12-12FL45	3/4	0.265	38.1	1.50	63.0	2.48	114.0	4.49	25.0	0.98
N12-16FL45	3/4	0.315	44.5	1.75	65.0	2.56	116.0	4.57	27.0	1.06
N16-16FL45	1	0.315	44.5	1.75	78.0	3.07	134.0	5.27	28.0	1.10
N16-20FL45	1	0.315	50.8	2.00	78.0	3.07	134.0	5.27	28.0	1.10
N20-16FL45	1 1/4	0.315	44.5	1.75	96.0	3.78	163.0	6.42	37.0	1.46
N20-20FL45	1 1/4	0.315	50.8	2.00	91.0	3.58	157.0	6.18	32.0	1.26
N20-24FL45	1 1/4	0.315	60.4	2.38	91.0	3.58	157.0	6.18	32.0	1.26
N24-24FL45	1 1/2	0.315	60.4	2.38	108.0	4.25	191.0	7.52	36.0	1.42
N24-32FL45	1 1/2	0.375	71.4	2.81	107.0	4.21	189.0	7.44	35.0	1.38
N32-32FL45	2	0.375	71.4	2.81	151.0	5.94	245.0	9.64	57.0	2.24

Reference Hose Section for Coupling Compatibility

COUPLINGS

FL60

SAE CODE 61 FLANGE - 60° ELBOW

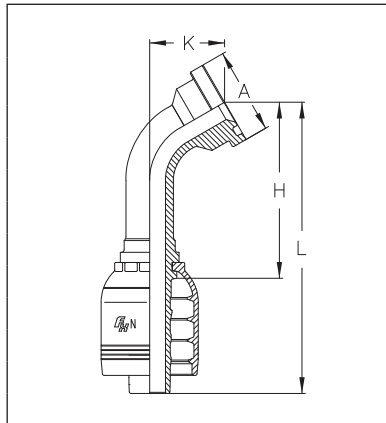

PART NUMBER	Hose Bore	FLANGE Thickness	A		H		L		K	
	INCH		[mm]	[in]	[mm]	[in]	[mm]	[in]	[mm]	[in]
N12-12FL60	3/4	0.265	38.1	1.50	77	3.03	128	5.04	34	1.34
N12-16FL60	3/4	0.315	44.5	1.75	79	3.11	130	5.12	37	1.46
N16-16FL60	1	0.315	44.5	1.75	98	3.86	154	6.06	40	1.57
N16-20FL60	1	0.315	50.8	2.00	98	3.86	154	6.06	40	1.57
N20-20FL60	1 1/4	0.315	50.8	2.00	118	4.64	184	7.24	45	1.77
N20-24FL60	1 1/4	0.315	60.4	2.38	118	4.64	184	7.24	45	1.77
N24-24FL60	1 1/2	0.315	60.4	2.38	140	5.51	223	8.78	52	2.05
N24-32FL60	1 1/2	0.375	71.4	2.81	139	5.47	222	8.74	50	1.97
N32-32FL60	2	0.375	71.4	2.81	192	7.56	289	11.38	73	2.87

FL67

SAE CODE 61 FLANGE - 67.5° ELBOW

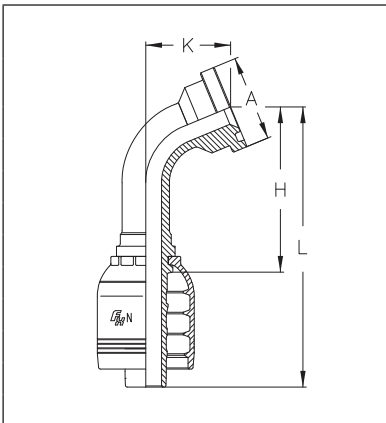

PART NUMBER	Hose Bore	FLANGE Thickness	A		H		L		K	
	INCH		[mm]	[in]	[mm]	[in]	[mm]	[in]	[mm]	[in]
N12-12FL67	3/4	0.265	38.1	1.50	72	2.83	123	4.84	39	1.53
N12-16FL67	3/4	0.315	44.5	1.75	73	2.87	124	4.88	41	1.61
N16-16FL67	1	0.315	44.5	1.75	92	3.62	148	5.83	45	1.77
N16-20FL67	1	0.315	50.8	2.00	92	3.62	148	5.83	45	1.77
N20-20FL67	1 1/4	0.315	50.8	2.00	111	4.37	178	7.01	52	2.05
N20-24FL67	1 1/4	0.315	60.4	2.38	111	4.37	178	7.01	52	2.05
N24-24FL67	1 1/2	0.315	60.4	2.38	133	5.24	216	8.50	60	2.36
N24-32FL67	1 1/2	0.375	71.4	2.81	132	5.20	215	8.46	58	2.28
N32-32FL67	2	0.375	71.4	2.81	181	7.12	278	10.94	84	3.31

Reference Hose Section for Coupling Compatibility

COUPLINGS

FL90

SAE CODE 61 FLANGE - 90° ELBOW

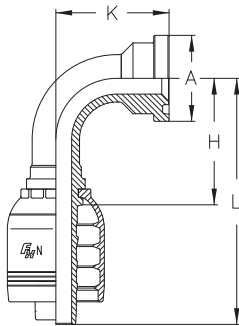

PART NUMBER	Hose Bore	FLANGE Thickness	A		H		L		K	
	INCH		[mm]	[in]	[mm]	[in]	[mm]	[in]	[mm]	[in]
N08-08FL90-042	1/2	0.265	30.2	1.19	41	1.61	74	2.91	42	1.65
N08-12FL90-050	1/2	0.265	38.1	1.50	41	1.61	74	2.91	50	1.97
N10-12FL90-047	5/8	0.265	38.1	1.50	49	1.93	85	3.35	55	2.17
N12-12FL90-051	3/4	0.265	38.1	1.50	55	2.16	106	4.17	51	2.00
N12-12FL90-096	3/4	0.265	38.1	1.50	55	2.16	106	4.17	96	3.77
N12-12FL90-127	3/4	0.265	38.1	1.50	55	2.16	106	4.17	127	5.00
N12-16FL90-055	3/4	0.315	44.5	1.75	55	2.16	106	4.17	55	2.16
N12-16FL90-079	3/4	0.315	44.5	1.75	55	2.16	106	4.17	79	3.11
N12-20FL90-060	3/4	0.315	50.8	2.00	55	2.16	106	4.17	60	2.36
N16-16FL90-061	1	0.315	44.5	1.75	71	2.79	128	5.03	61	2.40
N16-16FL90-118	1	0.315	44.5	1.75	71	2.79	128	5.03	118	4.64
N16-16FL90-158	1	0.315	44.5	1.75	71	2.79	128	5.03	158	6.22
N16-20FL90-061	1	0.315	50.8	2.00	71	2.79	128	5.03	61	2.40
N16-20FL90-118	1	0.315	50.8	2.00	71	2.79	128	5.03	118	4.64
N16-24FL90-061	1	0.315	60.4	2.38	71	2.79	128	5.03	61	2.40
N20-16FL90-079	1 1/4	0.315	44.5	1.75	87	3.42	154	6.06	79	3.11
N20-20FL90-071	1 1/4	0.315	50.8	2.00	87	3.42	154	6.06	71	2.79
N20-20FL90-091	1 1/4	0.315	50.8	2.00	87	3.42	154	6.06	91	3.58
N20-20FL90-102	1 1/4	0.315	50.8	2.00	87	3.42	154	6.06	102	4.01
N20-20FL90-112	1 1/4	0.315	50.8	2.00	87	3.42	154	6.06	112	4.40
N20-20FL90-130	1 1/4	0.315	50.8	2.00	87	3.42	154	6.06	130	5.11
N20-20FL90-168	1 1/4	0.315	50.8	2.00	87	3.42	154	6.06	168	6.61
N20-24FL90-071	1 1/4	0.315	60.4	2.38	87	3.42	154	6.06	71	2.79
N20-24FL90-118	1 1/4	0.315	60.4	2.38	87	3.42	154	6.06	118	4.64
N20-24FL90-130	1 1/4	0.315	60.4	2.38	87	3.42	154	6.06	130	5.11
N24-20FL90-090	1 1/2	0.315	50.8	2.00	98	3.85	180	7.09	90	3.54
N24-24FL90-083	1 1/2	0.315	60.4	2.38	105	4.13	188	7.40	83	3.26
N24-24FL90-148	1 1/2	0.315	60.4	2.38	105	4.13	188	7.40	148	5.82
N24-24FL90-172	1 1/2	0.315	60.4	2.38	105	4.13	188	7.40	172	6.77
N24-32FL90-081	1 1/2	0.375	71.4	2.81	105	4.13	188	7.40	81	3.18
N24-32FL90-115	1 1/2	0.375	71.4	2.81	105	4.13	188	7.40	115	4.52
N24-32FL90-172	1 1/2	0.375	71.4	2.81	105	4.13	188	7.40	172	6.77
N32-24FL90-081	2	0.375	60.3	2.37	136	5.38	233	9.18	81	3.19
N32-24FL90-105	2	0.375	60.3	2.37	136	5.38	233	9.18	105	4.13
N32-24FL90-152	2	0.375	60.3	2.37	136	5.38	233	9.18	152	5.98
N32-24FL90-156	2	0.375	60.3	2.37	136	5.38	233	9.18	156	6.14
N32-24FL90-228	2	0.375	60.3	2.37	136	5.38	233	9.18	228	8.98
N32-32FL90-117	2	0.375	71.4	2.81	140	5.51	237	9.33	122	4.80
N32-32FL90-122	2	0.375	71.4	2.81	140	5.51	237	9.33	122	4.80
N32-32FL90-165	2	0.375	71.4	2.81	140	5.51	237	9.33	165	6.49
N32-32FL90-203	2	0.375	71.4	2.81	140	5.51	237	9.33	203	7.99
N32-40FL90-117	2	0.375	84.1	3.31	140	5.51	237	9.33	117	4.60
N32-40FL90-132	2	0.375	84.1	3.31	140	5.51	237	9.33	117	4.60

Reference Hose Section for Coupling Compatibility

COUPLINGS

FL100 SAE CODE 61 FLANGE - 100° ELBOW

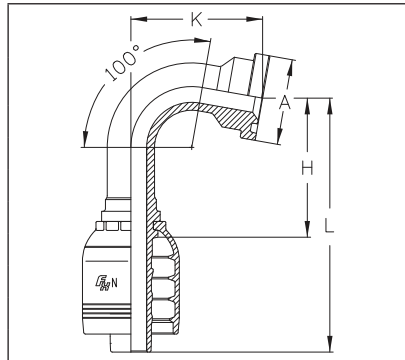

PART NUMBER	Hose Bore	FLANGE Thickness	A		H		L		K	
	INCH		[mm]	[in]	[mm]	[in]	[mm]	[in]	[mm]	[in]
N12-12FL100	3/4	0.265	38.1	1.50	61	2.40	112	4.41	59	2.32

FL110 SAE CODE 61 FLANGE - 110° ELBOW

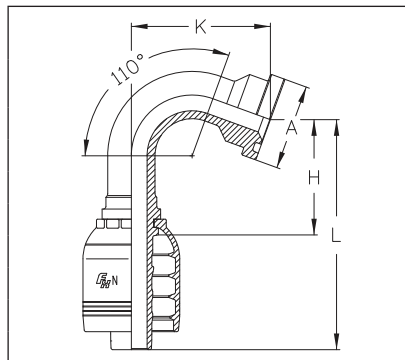

PART NUMBER	Hose Bore	FLANGE Thickness	A		H		L		K	
	INCH		[mm]	[in]	[mm]	[in]	[mm]	[in]	[mm]	[in]
N12-12FL110	3/4	0.265	38.1	1.50	51	2.01	102	4.01	62	2.44
N16-16FL110	1	0.315	44.5	1.75	65	2.56	121	4.76	73	2.87
N16-20FL110	1	0.315	50.8	2.00	65	2.56	121	4.76	73	2.87
N20-20FL110	1 1/4	0.315	50.8	2.00	82	3.23	148	5.83	83	3.27
N20-24FL110	1 1/4	0.315	60.4	2.38	82	3.23	148	5.83	83	3.27
N24-24FL110	1 1/2	0.315	60.4	2.38	95	3.74	178	7.01	97	3.82
N32-32FL110	2	0.375	71.4	2.81	124	4.88	220	8.66	142	5.59

FL135 SAE CODE 61 FLANGE - 135° ELBOW

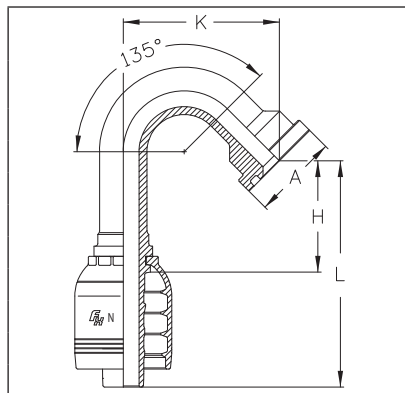

PART NUMBER	Hose Bore	FLANGE Thickness	A		H		L		K	
	INCH		[mm]	[in]	[mm]	[in]	[mm]	[in]	[mm]	[in]
N12-12FL135	3/4	0.265	38.1	1.50	69	2.72	120	4.72	70	2.75
N12-16FL135	3/4	0.315	44.5	1.75	69	2.72	120	4.72	70	2.75
N16-16FL135	1	0.315	44.5	1.75	57	2.24	113	4.45	86	3.38

Reference Hose Section for Coupling Compatibility

COUPLINGS

FLH

SAE CODE 62 FLANGE

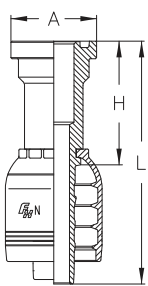

PART NUMBER	Hose Bore	FLANGE Thickness	A		H		L	
	INCH		[mm]	[in]	[mm]	[in]	[mm]	[in]
N08-08FLH	1/2	0.305	31.7	1.25	49.5	1.95	82.5	3.25
N08-12FLH	1/2	0.345	41.3	1.62	52.5	2.07	89.0	3.50
N10-12FLH	5/8	0.345	41.3	1.62	59.5	2.34	95.5	3.76
N12-12FLH	3/4	0.345	41.3	1.62	59.5	2.34	110.0	4.33
N12-16FLH	3/4	0.375	47.6	1.87	61.0	2.40	112.0	4.41
N16-12FLH	1	0.345	41.3	1.62	65.0	2.56	121.5	4.78
N16-16FLH	1	0.375	47.6	1.87	65.0	2.56	121.5	4.78
N16-20FLH	1	0.405	54.0	2.12	69.0	2.72	125.5	4.94
N20-16FLH	1 1/4	0.375	47.6	1.87	70.0	2.75	136.5	5.37
N20-20FLH	1 1/4	0.405	54.0	2.12	70.0	2.75	136.5	5.37
N20-24FLH	1 1/4	0.495	63.5	2.50	80.0	3.15	146.5	5.77
N24-24FLH	1 1/2	0.495	63.5	2.50	84.0	3.31	116.5	4.59
N24-32FLH	1 1/2	0.495	79.4	3.12	99.0	3.90	181.5	7.14
N32-32FLH	2	0.495	79.4	3.12	100.0	3.94	196.5	7.74

FLH22

SAE CODE 62 FLANGE - 22.5° ELBOW

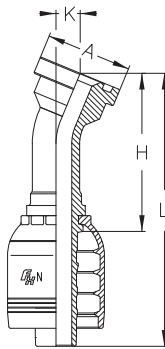

PART NUMBER	Hose Bore	FLANGE Thickness	A		H		L		K	
	INCH		[mm]	[in]	[mm]	[in]	[mm]	[in]	[mm]	[in]
N12-12FLH22	3/4	0.345	41.3	1.62	74	2.91	125	4.92	13	0.51
N12-16FLH22	3/4	0.375	47.6	1.87	76	2.99	127	5.00	14	0.55
N16-16FLH22	1	0.375	47.6	1.87	89	3.50	145	5.70	13	0.51
N16-20FLH22	1	0.405	54.0	2.12	89	3.50	145	5.70	13	0.51
N20-20FLH22	1 1/4	0.405	54.0	2.12	103	4.05	169	6.65	15	0.59
N20-24FLH22	1 1/4	0.495	63.5	2.50	104	4.09	171	6.73	15	0.59
N24-24FLH22	1 1/2	0.495	63.5	2.50	123	4.84	206	8.11	17	0.66
N24-32FLH22	1 1/2	0.495	79.4	3.12	127	5.00	210	8.26	19	0.74
N32-32FLH22	2	0.495	79.4	3.12	166	6.53	263	10.35	24	0.94

FLH30

SAE CODE 62 FLANGE - 30° ELBOW

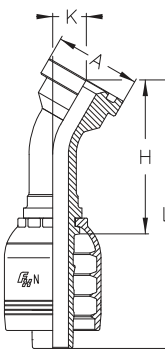

PART NUMBER	Hose Bore	FLANGE Thickness	A		H		L		K	
	INCH		[mm]	[in]	[mm]	[in]	[mm]	[in]	[mm]	[in]
N12-12FLH30	3/4	0.345	41.3	1.62	72	2.83	123	4.84	18	0.70
N12-16FLH30	3/4	0.375	47.6	1.87	74	2.91	125	4.92	19	0.74
N16-16FLH30	1	0.375	47.6	1.87	87	3.42	143	5.62	19	0.74
N16-20FLH30	1	0.405	54.0	2.12	87	3.42	143	5.62	19	0.74
N20-20FLH30	1 1/4	0.405	54.0	2.12	100	3.93	167	6.57	20	0.78
N20-24FLH30	1 1/4	0.495	63.5	2.50	102	4.01	168	6.61	21	0.82
N24-24FLH30	1 1/2	0.495	63.5	2.50	121	4.76	203	7.99	24	0.94
N24-32FLH30	1 1/2	0.495	79.4	3.12	124	4.88	207	8.14	26	1.02
N32-32FLH30	2	0.495	79.4	3.12	162	6.37	259	10.19	34	1.33

Reference Hose Section for Coupling Compatibility

COUPLINGS

FLH45 SAE CODE 62 FLANGE - 45° ELBOW

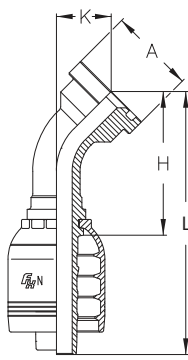

PART NUMBER	Hose Bore	FLANGE Thickness	A		H		L		K	
	INCH		[mm]	[in]	[mm]	[in]	[mm]	[in]	[mm]	[in]
N08-08FLH45	1/2	0.305	31.7	1.25	63.0	2.48	96.0	3.78	23.5	0.93
N08-12FLH45	1/2	0.345	41.3	1.62	68.5	2.70	101.5	4.00	29.0	1.14
N10-12FLH45	5/8	0.345	41.3	1.62	81.5	3.21	117.5	4.63	29.5	1.16
N12-12FLH45	3/4	0.345	41.3	1.62	66.0	2.59	117.0	4.60	28.0	1.10
N12-16FLH45	3/4	0.375	47.6	1.87	68.0	2.67	118.0	4.64	29.0	1.14
N16-12FLH45	1	0.345	41.3	1.62	81.0	3.18	137.0	5.39	31.0	1.22
N16-16FLH45	1	0.375	47.6	1.87	80.0	3.14	136.0	5.35	30.0	1.18
N16-20FLH45	1	0.405	54.0	2.12	80.0	3.14	136.0	5.35	30.0	1.18
N20-16FLH45	1 1/4	0.375	47.6	1.87	96.0	3.77	163.0	6.41	37.0	1.45
N20-20FLH45	1 1/4	0.405	54.0	2.12	93.0	3.66	160.0	6.29	34.0	1.33
N20-24FLH45	1 1/4	0.495	63.5	2.50	94.0	3.70	161.0	6.33	35.0	1.37
N24-24FLH45	1 1/2	0.495	63.5	2.50	112.0	4.40	195.0	7.67	40.0	1.57
N24-32FLH45	1 1/2	0.495	79.4	3.12	115.0	4.52	198.0	7.79	43.0	1.69
N32-32FLH45	2	0.495	79.4	3.12	150.0	5.90	247.0	9.72	56.0	2.20

FLH60 SAE CODE 62 FLANGE - 60° ELBOW

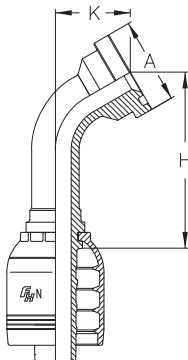

PART NUMBER	Hose Bore	FLANGE Thickness	A		H		L		K	
	INCH		[mm]	[in]	[mm]	[in]	[mm]	[in]	[mm]	[in]
N16-16FLH60	1	0.375	47.6	1.87	99	3.89	155	6.10	42	1.65
N20-20FLH60	1 1/4	0.405	54.0	2.12	119	4.68	185	7.28	47	1.85
N24-24FLH60	1 1/2	0.495	63.5	2.50	143	5.62	225	8.85	56	2.20
N32-32FLH60	2	0.495	79.4	3.12	193	7.59	289	11.37	79	3.11

FLH67 SAE CODE 62 FLANGE - 67.5° ELBOW

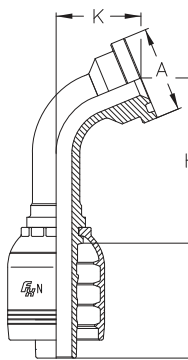

PART NUMBER	Hose Bore	FLANGE Thickness	A		H		L		K	
	INCH		[mm]	[in]	[mm]	[in]	[mm]	[in]	[mm]	[in]
N16-16FLH67	1	0.375	47.6	1.87	93	3.66	150	5.90	48	1.88
N20-20FLH67	1 1/4	0.405	54.0	2.12	112	4.40	179	7.04	54	2.12
N24-24FLH67	1 1/2	0.495	63.5	2.50	135	5.31	217	8.54	65	2.55
N32-32FLH67	2	0.495	79.4	3.12	182	7.16	278	10.94	90	3.54

Reference Hose Section for Coupling Compatibility

COUPLINGS

FLH90

SAE CODE 62 FLANGE - 90° ELBOW

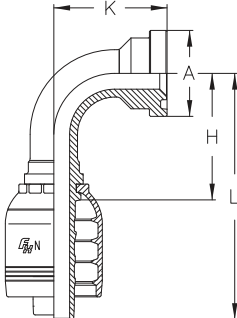

PART NUMBER	Hose Bore	FLANGE Thickness	A		H		L		K	
	INCH		[mm]	[in]	[mm]	[in]	[mm]	[in]	[mm]	[in]
N08-08FLH90-042	½	0.305	31.7	1.25	41	1.61	74	2.91	42	1.65
N08-12FLH90-050	½	0.345	41.3	1.62	41	1.61	74	2.91	50	1.97
N10-12FLH90-055	⅝	0.345	41.3	1.62	49	1.93	85	3.35	55	2.17
N12-12FLH90-056	¾	0.345	41.3	1.62	55	2.16	106	4.17	56	2.20
N12-12FLH90-100	¾	0.345	41.3	1.62	55	2.16	106	4.17	100	3.93
N12-16FLH90-058	¾	0.375	47.6	1.87	55	2.16	106	4.17	58	2.28
N12-16FLH90-140	¾	0.375	47.6	1.87	55	2.16	106	4.17	140	5.51
N16-12FLH90-065	1	0.345	41.3	1.62	71	2.79	128	5.03	65	2.55
N16-16FLH90-064	1	0.375	47.6	1.87	71	2.79	128	5.03	64	2.51
N16-16FLH90-120	1	0.375	47.6	1.87	71	2.79	128	5.03	120	4.72
N16-20FLH90-064	1	0.405	54.0	2.12	71	2.79	128	5.03	64	2.51
N20-16FLH90-079	1¼	0.375	47.6	1.87	87	3.42	154	6.06	79	3.11
N20-20FLH90-074	1¼	0.405	54.0	2.12	87	3.42	154	6.06	74	2.91
N20-20FLH90-120	1¼	0.405	54.0	2.12	87	3.42	154	6.06	120	4.72
N20-20FLH90-180	1¼	0.405	54.0	2.12	87	3.45	154	6.06	180	7.08
N20-24FLH90-076	1¼	0.495	63.5	2.50	87	3.42	154	6.06	76	2.99
N24-24FLH90-088	1½	0.495	63.5	2.50	105	4.13	188	7.40	88	3.46
N24-32FLH90-093	1½	0.495	79.4	3.12	105	4.13	188	7.40	93	3.66
N32-32FLH90-123	2	0.495	79.4	3.12	140	5.51	237	9.33	123	4.84

FLC

CATERPILLAR® FLANGE

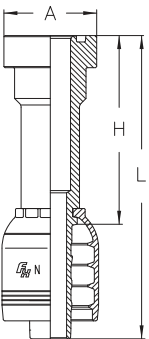

PART NUMBER	Hose Bore	FLANGE Thickness	A		H		L	
	INCH		[mm]	[in]	[mm]	[in]	[mm]	[in]
N12-12FLC	¾	0.560	41.3	1.62	84	3.30	135.0	5.31
N12-16FLC	¾	0.560	47.6	1.87	84	3.30	135.0	5.31
N16-16FLC	1	0.560	47.6	1.87	90	3.54	146.5	5.76
N16-20FLC	1	0.560	54.0	2.12	90	3.54	146.5	5.76
N20-20FLC	1¼	0.560	54.0	2.12	88	3.46	154.4	6.07
N20-24FLC	1¼	0.560	63.5	2.50	88	3.46	154.5	6.07

Use with D-Rings

Note: When using SAE 100R13 or 100R15 hose use VVS couplings.

Reference Hose Section for Coupling Compatibility

COUPLINGS

FLC22 CATERPILLAR® FLANGE - 22.5° ELBOW

PART NUMBER	Hose Bore	FLANGE Thickness	A		H		L		K	
	INCH		[mm]	[in]	[mm]	[in]	[mm]	[in]	[mm]	[in]
N12-12FLC22	¾	0.560	41.3	1.62	82	3.22	133	5.23	16	0.62
N12-16FLC22	¾	0.560	47.6	1.87	84	3.30	135	5.31	17	0.66
N16-16FLC22	1	0.560	47.6	1.87	97	3.81	153	6.02	17	0.66
N16-20FLC22	1	0.560	54.0	2.12	97	3.81	153	6.02	17	0.66
N20-20FLC22	1¼	0.560	54.0	2.12	106	4.17	172	6.77	16	0.62
N20-24FLC22	1¼	0.560	63.5	2.50	106	4.17	174	6.85	16	0.62

Note: When using SAE 100R13 or 100R15 hose use V/V5 couplings.

FLC30 CATERPILLAR® FLANGE - 30° ELBOW

PART NUMBER	Hose Bore	FLANGE Thickness	A		H		L		K	
	INCH		[mm]	[in]	[mm]	[in]	[mm]	[in]	[mm]	[in]
N12-12FLC30	¾	0.560	41.3	1.62	79	3.11	130	5.11	22	0.86
N12-16FLC30	¾	0.560	47.6	1.87	82	3.22	133	5.23	23	0.90
N16-16FLC30	1	0.560	47.6	1.87	94	3.70	151	5.94	23	0.90
N16-20FLC30	1	0.560	54.0	2.12	94	3.70	151	5.94	23	0.90
N20-20FLC30	1¼	0.560	54.0	2.12	103	4.05	170	6.69	22	0.86
N20-24FLC30	1¼	0.560	63.5	2.50	104	4.09	170	6.69	23	0.90

Use with D-Rings

Note: When using SAE 100R13 or 100R15 hose use V/V5 couplings.

FLC45 CATERPILLAR® FLANGE - 45° ELBOW

PART NUMBER	Hose Bore	FLANGE Thickness	A		H		L		K	
	INCH		[mm]	[in]	[mm]	[in]	[mm]	[in]	[mm]	[in]
N12-12FLC45	¾	0.560	41.3	1.62	72	2.83	123	4.84	34	1.33
N12-16FLC45	¾	0.560	47.6	1.87	74	2.91	125	4.92	36	1.41
N16-16FLC45	1	0.560	47.6	1.87	86	3.38	143	5.62	36	1.41
N16-20FLC45	1	0.560	54.0	2.12	86	3.38	143	5.62	36	1.41
N20-20FLC45	1¼	0.560	54.0	2.12	96	3.77	162	6.37	36	1.41
N20-24FLC45	1¼	0.560	63.5	2.50	96	3.77	162	6.37	36	1.41

Use with D-Rings

Note: When using SAE 100R13 or 100R15 hose use V/V5 couplings.

COUPLINGS

FLC60 CATERPILLAR® FLANGE - 60° ELBOW

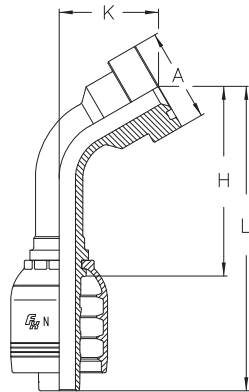

PART NUMBER	Hose Bore	FLANGE Thickness	A		H		L		K	
	INCH		[mm]	[in]	[mm]	[in]	[mm]	[in]	[mm]	[in]
N12-12FLC60	3/4	0.560	41.3	1.62	83	3.26	134	5.27	45	1.77
N12-16FLC60	3/4	0.560	47.6	1.87	85	3.34	136	5.35	48	1.88
N16-16FLC60	1	0.560	47.6	1.87	103	4.05	160	6.29	50	1.96
N16-20FLC60	1	0.560	54.0	2.12	103	4.05	160	6.29	50	1.96
N20-20FLC60	1 1/4	0.560	54.0	2.12	121	4.76	187	7.36	50	1.96
N20-24FLC60	1 1/4	0.560	63.5	2.50	121	4.76	187	7.36	51	2.00

Use with D-Rings

Note: When using SAE 100R13 or 100R15 hose use V/VS couplings.

FLC67 CATERPILLAR® FLANGE - 67.5° ELBOW

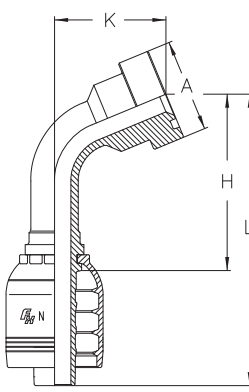

PART NUMBER	Hose Bore	FLANGE Thickness	A		H		L		K	
	INCH		[mm]	[in]	[mm]	[in]	[mm]	[in]	[mm]	[in]
N12-12FLC67	3/4	0.560	41.3	1.62	77	3.03	128	5.03	50	1.96
N12-16FLC67	3/4	0.560	47.6	1.87	79	3.11	130	5.11	53	2.08
N16-16FLC67	1	0.560	47.6	1.87	97	3.81	153	6.02	56	2.20
N20-20FLC67	1 1/4	0.560	54.0	2.12	114	4.48	181	7.12	57	2.24

Use with D-Rings

Note: When using SAE 100R13 or 100R15 hose use V/VS couplings.

FLC90 CATERPILLAR® FLANGE - 90° ELBOW

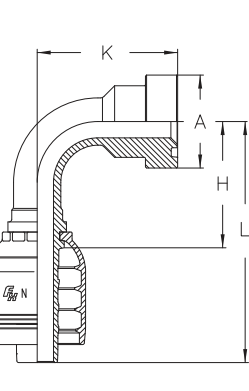

PART NUMBER	Hose Bore	FLANGE Thickness	A		H		L		K	
	INCH		[mm]	[in]	[mm]	[in]	[mm]	[in]	[mm]	[in]
N12-12FLC90-064	3/4	0.560	41.3	1.62	55	2.16	106	4.17	64	2.52
N12-12FLC90-129	3/4	0.560	41.3	1.62	55	2.16	106	4.17	129	5.07
N12-16FLC90-064	3/4	0.560	47.6	1.87	55	2.16	106	4.17	64	2.51
N16-16FLC90-073	1	0.560	47.6	1.87	71	2.79	128	5.03	73	2.87
N16-16FLC90-132	1	0.560	47.6	1.87	71	2.79	128	5.03	132	5.19
N16-20FLC90-073	1	0.560	54.0	2.12	71	2.79	128	5.03	73	2.87
N20-20FLC90-077	1 1/4	0.560	54.0	2.12	87	3.42	154	6.06	77	3.03
N20-20FLC90-150	1 1/4	0.560	54.0	2.12	87	3.42	154	6.06	150	5.90
N20-24FLC90-078	1 1/4	0.560	63.5	2.50	87	3.42	154	6.06	78	3.07
N20-24FLC90-135	1 1/4	0.560	63.5	2.50	87	3.42	154	6.06	135	5.31
N24-24FLC90-090	1 1/2	0.560	63.5	2.50	105	4.13	188	7.40	90	3.54
N24-32FLC90-094	1 1/2	0.560	79.4	3.13	105	4.13	188	7.40	94	3.70
N32-32FLC90-125	2	0.560	79.4	3.13	140	5.51	237	9.33	125	4.92

Use with D-Rings

Note: When using SAE 100R13 or 100R15 hose use V/VS couplings.

COUPLINGS

1901 SPLIT FLANGE KIT (CODE 61)

	PART NUMBER	SIZE
	1901-08-K	1/2
	1901-12-K	3/4
	1901-16-K	1
	1901-20-K	1 1/4
	1901-24-K	1 1/2
	1901-32-K	2

1902 SPLIT FLANGE KIT (CODE 62)

	PART NUMBER	SIZE
	1902-08-K	1/2
	1902-12-K	3/4
	1902-16-K	1
	1902-20-K	1 1/4
	1902-24-K	1 1/2
	1902-32-K	2

1903 CATERPILLAR® SPLIT FLANGE KIT

	PART NUMBER	SIZE
	1903-12-K	3/4
	1903-16-K	1
	1903-20-K	1 1/4
	1903-24-K	1 1/2
	1903-32-K	2

Reference Hose Section for Coupling Compatibility

COUPLINGS

MP

NPT MALE

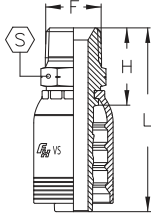

PART NUMBER	Hose Bore	F	H		L		S	
	INCH		[mm]	[in]	[mm]	[in]	[mm]	[in]
V06-06MP	3/8	3/8 - 18	28.6	1.12	59.1	2.32	19	3/4
V06-08MP	3/8	1/2 - 14	34.0	1.33	64.5	2.53	22	7/8
V08-06MP	1/2	3/8 - 18	30.6	1.20	63.6	2.50	22	7/8
V08-08MP	1/2	1/2 - 14	35.0	1.37	68.0	2.67	22	7/8
V08-12MP	1/2	3/4 - 14	36.9	1.45	69.9	2.75	27	1 1/16
V10-12MP	5/8	3/4 - 14	37.1	1.46	72.9	2.87	27	1 1/16
V12-12MP	3/4	3/4 - 14	39.0	1.53	90.0	3.54	27	1 1/16
V12-16MP	3/4	1 - 11 1/2	47.0	1.85	98.0	3.85	36	1 7/16
V16-12MP	1	3/4 - 14	41.5	1.63	98.0	3.85	32	1 1/4
V16-16MP	1	1 - 11 1/2	48.5	1.90	105.0	4.13	36	1 7/16
V16-20MP	1	1 1/4 - 11 1/2	53.0	2.08	109.5	4.31	46	1 13/16
VS20-20MP	1 1/4	1 1/4 - 11 1/2	55.0	2.16	121.5	4.78	46	1 13/16
VS20-24MP	1 1/4	1 1/2 - 11 1/2	59.0	2.32	125.5	4.94	50	2
VS24-24MP	1 1/2	1 1/2 - 11 1/2	61.0	2.40	143.5	5.64	50	2
VS32-32MP	2	2 - 11 1/2	70.5	2.77	167.0	6.57	65	2 9/16
VS32-32MPA*	2	2 - 11 1/2	112.3	4.42	208.8	8.22	65	2 9/16

* API VERSION

MJ

JIC 37° MALE

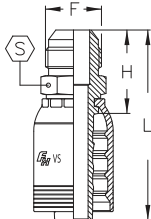

PART NUMBER	Hose Bore	F	H		L		S	
	INCH		[mm]	[in]	[mm]	[in]	[mm]	[in]
V06-06MJ	3/8	9/16 - 18	26.6	1.04	57.1	2.24	15	5/8
V06-08MJ	3/8	3/4 - 16	29.7	1.16	60.2	2.37	19	3/4
V08-08MJ	1/2	3/4 - 16	30.7	1.20	63.7	2.50	19	3/4
V08-10MJ	1/2	7/8 - 14	35.3	1.38	68.3	2.68	24	1
V08-12MJ	1/2	1 1/16 - 12	38.9	1.53	71.9	2.83	27	1 1/16
V10-10MJ	5/8	7/8 - 14	35.5	1.39	71.3	2.80	24	1
V10-12MJ	5/8	1 1/16 - 12	39.1	1.53	74.9	2.94	27	1 1/16
V12-10MJ	3/4	7/8 - 14	37.0	1.45	88.0	3.46	27	1 1/16
V12-12MJ	3/4	1 1/16 - 12	40.0	1.57	91.0	3.58	27	1 1/16
V12-14MJ	3/4	1 3/16 - 12	41.5	1.63	92.5	3.64	32	1 1/4
V12-16MJ	3/4	1 5/16 - 12	43.0	1.69	94.0	3.70	36	1 7/16
V16-16MJ	1	1 5/16 - 12	45.0	1.77	101.5	3.99	36	1 7/16
V16-20MJ	1	1 5/8 - 12	48.0	1.88	104.5	4.11	46	1 13/16
VS20-20MJ	1 1/4	1 5/8 - 12	50.5	1.98	117.0	4.60	46	1 13/16
VS24-24MJ	1 1/2	1 7/8 - 12	57.0	2.24	139.5	5.49	50	2
VS32-32MJ	2	2 1/2 - 12	68.5	2.69	165.0	6.49	65	2 9/16

Reference Hose Section for Coupling Compatibility

COUPLINGS

FJ JIC 37° FEMALE SWIVEL

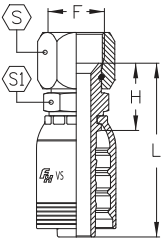
	PART NUMBER	Hose Bore	F	H		L		S		S1	
		INCH		[mm]	[in]	[mm]	[in]	[mm]	[in]	[mm]	[in]
	V06-06FJ	3/8	9/16 - 18	22.5	0.88	53.0	2.08	19	3/4	16	5/8
	V06-08FJ	3/8	3/4 - 16	24.5	0.96	55.0	2.16	22	7/8	19	3/4
	V08-06FJ	1/2	9/16 - 18	24.5	0.96	57.5	2.26	19	3/4	19	3/4
	V08-08FJ	1/2	3/4 - 16	25.5	1.00	58.5	2.30	22	7/8	19	3/4
	V08-10FJ	1/2	7/8 - 14	27.5	1.08	60.5	2.38	27	1 1/16	22	7/8
	V08-12FJ	1/2	1 1/16 - 12	30.3	1.19	63.3	2.49	32	1 1/4	25	1
	V10-10FJ	5/8	7/8 - 14	27.7	1.09	63.5	2.50	27	1 1/16	22	7/8
	V10-12FJ	5/8	1 1/16 - 12	30.5	1.20	66.3	2.61	32	1 1/4	25	1
	V12-10FJ	3/4	7/8 - 14	33.0	1.29	84.0	3.30	27	1 1/16	27	1 1/16
	V12-12FJ	3/4	1 1/16 - 12	34.0	1.33	85.0	3.34	32	1 1/4	27	1 1/16
	V12-14FJ	3/4	1 3/16 - 12	35.5	1.39	86.5	3.40	36	1 7/16	30	1 3/16
	V12-16FJ	3/4	1 5/16 - 12	38.0	1.49	89.0	3.50	41	1 5/8	32	1 1/4
	V16-12FJ	1	1 1/16 - 12	36.5	1.43	93.0	3.66	32	1 1/4	32	1 1/4
	V16-16FJ	1	1 5/16 - 12	39.5	1.55	96.0	3.77	41	1 5/8	32	1 1/4
	V16-20FJ	1	1 5/8 - 12	46.0	1.81	102.5	4.03	50	2	41	1 5/8
	VS20-16FJ	1 1/4	1 5/16 - 12	45.5	1.79	112.0	4.40	41	1 5/8	41	1 5/8
	VS20-20FJ	1 1/4	1 5/8 - 12	48.0	1.88	114.5	4.50	50	2	41	1 5/8
	VS20-24FJ	1 1/4	1 7/8 - 12	51.0	2.00	117.5	4.62	60	2 3/8	46	1 13/16
	VS24-24FJ	1 1/2	1 7/8 - 12	53.0	2.08	135.5	5.33	60	2 3/8	46	1 13/16
	VS32-32FJ	2	2 1/2 - 12	69.0	2.71	165.5	6.51	75	3	60	2 3/8

FJ45 JIC 37° FEMALE SWIVEL - 45° ELBOW

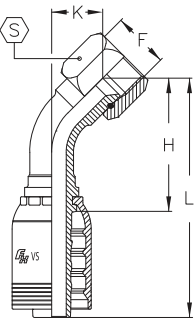
	PART NUMBER	Hose Bore	F	H		L		K		S	
		INCH		[mm]	[in]	[mm]	[in]	[mm]	[in]	[mm]	[in]
	V06-06FJ45	3/8	9/16 - 18	35.5	1.39	66.0	2.59	12.0	0.47	19	3/4
	V06-08FJ45	3/8	3/4 - 16	37.5	1.47	68.0	2.67	14.0	0.55	22	7/8
	V08-08FJ45	1/2	3/4 - 16	41.0	1.61	74.0	2.91	14.5	0.57	22	7/8
	V08-10FJ45	1/2	7/8 - 14	43.0	1.69	76.0	2.99	16.0	0.62	27	1 1/16
	V08-12FJ45	1/2	1 1/16 - 12	45.5	1.79	78.5	3.09	19.0	0.74	32	1 1/4
	V10-10FJ45	5/8	7/8 - 14	47.0	1.85	83.0	3.27	16.0	0.63	27	1 1/16
	V10-12FJ45	5/8	1 1/16 - 12	50.0	1.97	86.0	3.38	19.0	0.75	32	1 1/4
	V12-12FJ45	3/4	1 1/16 - 12	63.0	2.48	114.0	4.48	25.0	0.98	32	1 1/4
	V12-16FJ45	3/4	1 5/16 - 12	63.0	2.48	114.0	4.48	25.0	0.98	41	1 5/8
	V16-16FJ45	1	1 5/16 - 12	82.0	3.22	138.0	5.43	32.0	1.25	41	1 5/8
	V16-20FJ45	1	1 5/8 - 12	82.0	3.22	138.0	5.43	32.0	1.25	50	2
	VS20-20FJ45	1 1/4	1 5/8 - 12	98.0	3.85	164.0	6.45	38.0	1.49	50	2
	VS20-24FJ45	1 1/4	1 7/8 - 12	98.0	3.85	164.0	6.45	38.0	1.49	60	2 1/2
	VS24-24FJ45	1 1/2	1 7/8 - 12	118.0	4.64	201.0	7.91	46.0	1.81	60	2 1/2
	VS32-32FJ45	2	2 1/2 - 12	157.0	6.18	253.0	9.96	62.0	2.44	75	3

Reference Hose Section for Coupling Compatibility

COUPLINGS

FJ90S JIC 37° FEMALE SWIVEL - 90° ELBOW SHORT DROP

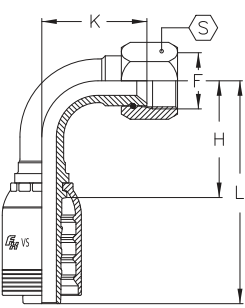

PART NUMBER	Hose Bore	F	H		L		K		⊕	
	INCH		[mm]	[in]	[mm]	[in]	[mm]	[in]	[mm]	[in]
V06-06FJ90S	3/8	9/16 - 18	31	1.22	60.5	2.38	23	0.91	19	3/4
V06-08FJ90S	3/8	3/4 - 16	31	1.22	61.5	2.42	29	1.14	22	7/8
V08-08FJ90S	1/2	3/4 - 16	37	1.45	70.0	2.75	29	1.14	22	7/8
V08-10FJ90S	1/2	7/8 - 14	37	1.45	70.0	2.75	40	1.57	27	1 1/16
V08-12FJ90S	1/2	1 1/16 - 12	38	1.50	73.0	2.87	40	1.57	32	1 1/4
V10-10FJ90S	5/8	7/8 - 14	43	1.69	79.0	3.11	32	1.26	27	1 1/16
V10-12FJ90S	5/8	1 1/16 - 12	45	1.77	81.0	3.19	47	1.85	32	1 1/4

FJ90M JIC 37° FEMALE SWIVEL - 90° ELBOW MEDIUM DROP

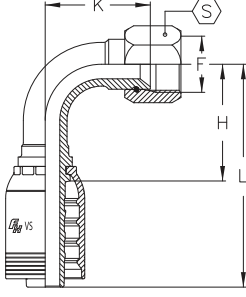

PART NUMBER	Hose Bore	F	H		L		K		⊕	
	INCH		[mm]	[in]	[mm]	[in]	[mm]	[in]	[mm]	[in]
V12-12FJ90M	3/4	1 1/16 - 12	55	2.16	106.0	4.17	52	2.04	32	1 1/4
V12-16FJ90M	3/4	1 5/16 - 12	55	2.16	106.0	4.17	52	2.04	41	1 5/8
V16-16FJ90M	1	1 5/16 - 12	71	2.79	128.0	5.03	67	2.63	36	1 7/16
V16-20FJ90M	1	1 5/8 - 12	71	2.79	128.0	5.03	67	2.63	50	2
VS20-20FJ90M	1 1/4	1 5/8 - 12	87	3.42	154.0	6.06	81	3.18	50	2
VS20-24FJ90M	1 1/4	1 7/8 - 12	87	3.42	154.0	6.06	81	3.18	60	2 1/2
VS24-24FJ90M	1 1/2	1 7/8 - 12	105	4.13	188.0	7.40	97	3.81	60	2 1/2
VS32-32FJ90M	2	2 1/2 - 12	140	5.51	237.0	9.33	132	5.19	75	3

FJ90L JIC 37° FEMALE SWIVEL - 90° ELBOW LONG DROP

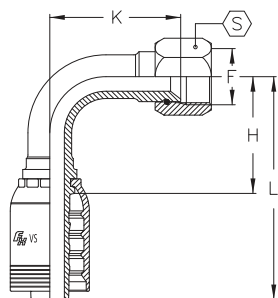

PART NUMBER	Hose Bore	F	H		L		K		⊕	
	INCH		[mm]	[in]	[mm]	[in]	[mm]	[in]	[mm]	[in]
V06-06FJ90L	3/8	9/16 - 18	31	1.22	61.5	2.42	54	2.12	19	3/4
V08-08FJ90L	1/2	3/4 - 16	38	1.49	71.0	2.79	64	2.51	22	7/8
V08-10FJ90L	1/2	7/8 - 14	38	1.49	71.0	2.79	70	2.75	27	1 1/16
V12-12FJ90L	3/4	1 1/16 - 12	55	2.16	106.0	4.17	96	3.77	32	1 1/4
V16-16FJ90L	1	1 5/16 - 12	71	2.79	128.0	5.03	116	4.56	41	1 5/8
VS20-20FJ90L	1 1/4	1 5/8 - 12	87	3.42	154.0	6.06	136	5.35	50	2

Reference Hose Section for Coupling Compatibility

COUPLINGS

MF ORFS MALE O-RING FACE SEAL

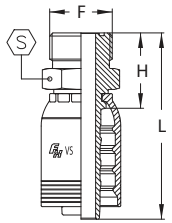
	PART NUMBER	Hose Bore	F	H		L		S	
		INCH		[mm]	[in]	[mm]	[in]	[mm]	[in]
				V06-06MF	3/8	1 1/16 - 16	25.5	1.00	56
	V06-08MF	3/8	1 3/16 - 16	28.5	1.12	59	2.32	22	7/8
	V08-08MF	1/2	1 3/16 - 16	29.5	1.16	62.5	2.46	22	7/8
	V08-10MF	1/2	1 - 14	34.0	1.33	67	2.63	27	1 1/16
	V08-12MF	1/2	1 3/16 - 12	37.0	1.45	70	2.75	32	1 1/4
	V10-10MF	5/8	1 - 14	34.0	1.33	70	2.75	27	1 1/16
	V10-12MF	5/8	1 3/16 - 12	37.0	1.45	73	2.87	32	1 1/4
	V12-12MF	3/4	1 3/16 - 12	36.0	1.41	87	3.42	32	1 1/4
	V16-16MF	1	1 7/16 - 12	41.0	1.61	97	3.81	41	1 5/8
	VS20-20MF	1 1/4	1 11/16 - 12	44.0	1.73	111	4.37	46	1 13/16
	VS24-24MF	1 1/2	2 - 12	48.0	1.88	131	5.15	55	2 1/4

FF ORFS FEMALE SWIVEL

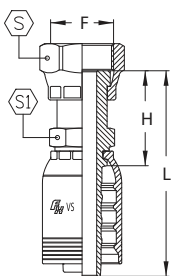
	PART NUMBER	Hose Bore	F	H		L		S		S1	
		INCH		[mm]	[in]	[mm]	[in]	[mm]	[in]	[mm]	[in]
				V06-06FF	3/8	1 1/16 - 16	28.5	1.12	59.0	2.32	22
	V06-08FF	3/8	1 3/16 - 16	32.5	1.27	63.0	2.48	24	1	19	3/4
	V08-06FF	1/2	1 1/16 - 16	30.5	1.20	63.5	2.50	22	7/8	19	3/4
	V08-08FF	1/2	1 3/16 - 16	33.5	1.31	66.5	2.61	24	1	19	3/4
	V08-10FF	1/2	1 - 14	39.5	1.55	72.5	2.85	30	1 3/16	24	1
	V08-12FF	1/2	1 3/16 - 12	43.5	1.71	76.5	3.01	36	1 7/16	27	1 1/16
	V10-10FF	5/8	1 - 14	39.5	1.55	75.5	2.97	30	1 3/16	24	1
	V10-12FF	5/8	1 3/16 - 12	43.5	1.71	79.5	3.12	36	1 7/16	27	1 1/16
	V12-10FF	3/4	1 - 14	43.0	1.69	94.0	3.70	30	1 3/16	27	1 1/16
	V12-12FF	3/4	1 3/16 - 12	46.0	1.81	97.0	3.81	36	1 7/16	30	1 3/16
	V12-16FF	3/4	1 7/16 - 12	49.0	1.93	100.0	3.94	41	1 5/8	36	1 7/16
	V16-16FF	1	1 7/16 - 12	51.0	2.00	107.0	4.21	41	1 5/8	36	1 7/16
	V16-20FF	1	1 11/16 - 12	52.0	2.04	109.0	4.29	50	2	41	1 5/8
	VS20-20FF	1 1/4	1 11/16 - 12	55.0	2.16	121.0	4.76	50	2	41	1 5/8
	VS24-24FF	1 1/2	2 - 12	60.0	2.36	142.0	5.59	60	2 3/8	50	2

Reference Hose Section for Coupling Compatibility

COUPLINGS

FF45 ORFS FEMALE SWIVEL - 45° ELBOW

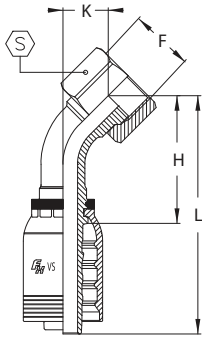

PART NUMBER	Hose Bore	F	H		L		K		S	
	INCH		[mm]	[in]	[mm]	[in]	[mm]	[in]	[mm]	[in]
V06-06FF45	3/8	1 1/16 - 16	36.0	1.41	66.5	2.61	12.5	0.49	22	7/8
V06-08FF45	3/8	1 3/16 - 16	38.5	1.51	69.0	2.71	15.0	0.59	24	1
V08-08FF45	1/2	1 3/16 - 16	42.5	1.67	75.5	2.97	15.5	0.61	24	1
V08-10FF45	1/2	1 - 14	45.0	1.77	78.0	3.07	17.5	0.68	30	1 3/16
V08-12FF45	1/2	1 3/16 - 12	47.0	1.85	80.0	3.14	20.5	0.80	36	1 7/16
V10-10FF45	5/8	1 - 14	49.0	1.92	85.0	3.34	18.0	0.70	30	1 3/16
V10-12FF45	5/8	1 3/16 - 12	51.5	2.02	87.5	3.44	20.5	0.80	36	1 7/16
V12-12FF45	3/4	1 3/16 - 12	60.0	2.36	111.0	4.37	22.0	0.86	36	1 7/16
V16-16FF45	1	1 7/16 - 12	78.0	3.07	134.0	5.27	29.0	1.14	41	1 5/8
V16-20FF45	1	1 11/16 - 12	78.0	3.07	134.0	5.27	29.0	1.14	50	2
VS20-20FF45	1 1/4	1 11/16 - 12	93.0	3.66	159.0	6.25	34.0	1.33	50	2
VS24-24FF45	1 1/2	2 - 12	113	4.44	195.0	7.67	41.0	1.61	60	2 3/8

FF90S ORFS FEMALE SWIVEL - 90° ELBOW SHORT DROP

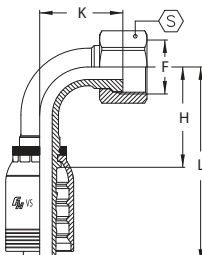

PART NUMBER	Hose Bore	F	H		L		K		S	
	INCH		[mm]	[in]	[mm]	[in]	[mm]	[in]	[mm]	[in]
V12-12FF90S	3/4	1 3/16 - 12	54	2.13	105	4.13	48	1.89	36	1 7/16
V16-16FF90S	1	1 7/16 - 12	71	2.80	127	5.00	62	2.44	41	1 5/8
V16-20FF90S	1	1 7/16 - 12	71	2.80	127	5.00	62	2.44	50	2
VS20-20FF90M	1 1/4	1 11/16 - 12	87	3.42	153	6.02	75	2.95	50	2
VS24-24FF90M	1 1/2	2 - 12	105	4.13	187	7.36	90	3.54	60	2 3/8

FF90L ORFS FEMALE SWIVEL - 90° ELBOW LONG DROP

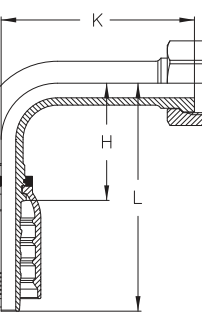

PART NUMBER	Hose Bore	F	H		L		K		S	
	INCH		[mm]	[in]	[mm]	[in]	[mm]	[in]	[mm]	[in]
V12-12FF90L	3/4	1 3/16 - 12	54	2.12	105.0	4.13	96	3.77	36	1 7/16
V16-16FF90L	1	1 7/16 - 12	71	2.79	127.0	5.00	114	4.48	41	1 5/8
VS20-20FF90L	1 1/4	1 11/16 - 12	87	3.42	153.0	6.02	130	5.11	50	2
VS24-24FF90L	1 1/2	2 - 12	105	4.13	187.0	7.36	155	6.10	60	2 3/8

MOB O-RING BOSS MALE

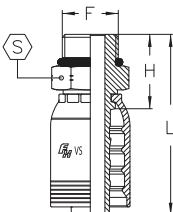

PART NUMBER	Hose Bore	F	H		L		S	
	INCH		[mm]	[in]	[mm]	[in]	[mm]	[in]
V06-06MOB	3/8	9/16 - 18	23.5	0.92	54.0	2.12	17	1 1/16
V08-08MOB	1/2	3/4 - 16	27.2	1.07	60.2	2.37	22	7/8

Reference Hose Section for Coupling Compatibility

COUPLINGS

FJIS JIS FEMALE SWIVEL (TOYOTA)

	PART NUMBER	Hose Bore	F	H		L		S		S1	
		INCH		[mm]	[in]	[mm]	[in]	[mm]	[in]	[mm]	[in]
	V06-06FJIS	3/8	3/8 - 19	26	1.02	57	2.24	22	7/8	17	1 1/16
V08-08FJIS	1/2	1/2 - 14	30	1.18	63	2.48	27	1 1/16	22	7/8	

FK KOMATSU FEMALE SWIVEL

	PART NUMBER	Hose Bore	F	H		L		S		S1	
		INCH		[mm]	[in]	[mm]	[in]	[mm]	[in]	[mm]	[in]
	V06-18FK	3/8	M18 x 1.5	24.3	0.95	54.8	2.15	24.0	1	19	3/4
V06-20FK	3/8	M20 x 1.5	29.0	1.14	59.0	2.32	25.4	1	22	7/8	
V06-22FK	3/8	M22 x 1.5	29.0	1.14	59.0	2.32	27.0	1 1/16	22	7/8	
V08-18FK	1/2	M18 x 1.5	26.0	1.02	59.0	2.32	24.0	1	22	7/8	
V08-22FK	1/2	M22 x 1.5	26.5	1.04	59.5	2.34	27.0	1 1/16	27	1 1/16	
V08-24FK	1/2	M24 x 1.5	29.9	1.17	62.9	2.47	32.0	1 1/4	32	1 1/4	
V10-24FK	5/8	M24 x 1.5	29.9	1.17	65.9	2.59	32.0	1 1/4	32	1 1/4	
V12-24FK	3/4	M24 x 1.5	33.0	1.30	84.0	3.31	32.0	1 1/4	32	1 1/4	
V12-30FK	3/4	M30 x 1.5	36.0	1.42	87.0	3.43	36.0	1 7/16	36	1 7/16	
V16-33FK	1	M33 x 1.5	38.0	1.50	95.0	3.74	41.0	1 5/8	36	1 7/16	
V16-36FK	1	M36 x 1.5	42.0	1.65	98.0	3.86	46.0	1 13/16	41	1 5/8	
VS20-36FK	1 1/4	M36 x 1.5	44.0	1.73	110.5	4.35	46.0	1 13/16	41	1 5/8	
VS24-42FK	1 1/2	M42 x 1.5	49.0	1.93	131.0	5.16	50.0	2	50	2	

FLK KOMATSU FLANGE

	PART NUMBER	Hose Bore	FLANGE	A		H		L	
		INCH		[mm]	[in]	[mm]	[in]	[mm]	[in]
	V08-10FLK	1/2	34mm x .265	34	1.33	49.3	1.94	82.3	3.24
V10-10FLK	5/8	34mm x .265	34	1.33	49.3	1.94	85.3	3.35	

Reference Hose Section for Coupling Compatibility

COUPLINGS

FLK45 KOMATSU FLANGE - 45° ELBOW

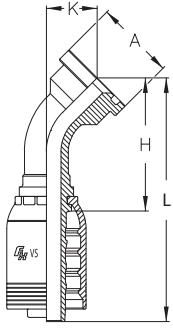

PART NUMBER	Hose Bore	FLANGE	A		H		L		K	
	INCH		[mm]	[in]	[mm]	[in]	[mm]	[in]	[mm]	[in]
V08-10FLK45	1/2	34mm x .265	34	1.33	71	2.79	104	4.09	27.5	1.08
V10-10FLK45	5/8	34mm x .265	34	1.33	70	2.75	110	4.33	30.0	1.18

FLK90 KOMATSU FLANGE - 90° ELBOW

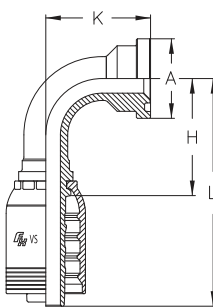

PART NUMBER	Hose Bore	FLANGE	A		H		L		K	
	INCH		[mm]	[in]	[mm]	[in]	[mm]	[in]	[mm]	[in]
V08-10FLK90	1/2	34mm x .265	34	1.33	41	1.61	74	2.91	44	1.73
V10-10FLK90	5/8	34mm x .265	34	1.33	49	1.92	85	3.34	49	1.92

MKBC KOBELCO MALE

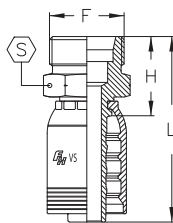

PART NUMBER	Hose Bore	F	H		L		S	
	INCH		[mm]	[in]	[mm]	[in]	[mm]	[in]
V12-30MKBC	3/4	M30 x 1.5	39.2	1.54	90.2	3.55	38	1.50
V12-36MKBC	3/4	M36 x 1.5	39.2	1.54	90.2	3.55	41	1.61
V16-36MKBC	1	M36 x 1.5	42.5	1.67	99.0	3.90	41	1.61
V16-45MKBC	1	M45 x 1.5	45.0	1.77	101.6	4.00	50	1.97

MBSPT BSPT MALE

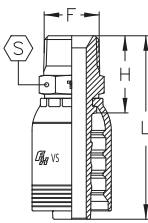

PART NUMBER	Hose Bore	F	H		L		S	
	INCH		[mm]	[in]	[mm]	[in]	[mm]	[in]
V06-06MBSPT	3/8	3/8 - 19	27	1.06	57	2.24	19	3/4
V08-08MBSPT	1/2	1/2 - 14	33	1.29	66	2.59	22	7/8
V12-12MBSPT	3/4	3/4 - 14	37	1.45	88	3.46	27	1 1/16
V16-16MBSPT	1	1 - 11	44	1.73	101	3.97	36	1 7/16
VS20-20MBSPT	1 1/4	1 1/4 - 11	51	2.00	118	4.64	46	1 13/16
VS24-24MBSPT	1 1/2	1 1/2 - 11	54	2.12	137	5.39	50	2
VS32-32MBSPT	2	2 - 11	64	2.51	160	6.29	65	2 9/16

Reference Hose Section for Coupling Compatibility

COUPLINGS

MBSPP BSPP MALE (60° SEAT)

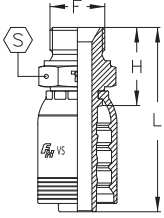

PART NUMBER	Hose Bore	F	H		L		S	
	INCH		[mm]	[in]	[mm]	[in]	[mm]	[in]
V06-06MBSPP	3/8	3/8 - 19	27	1.06	58	2.28	22	7/8
V06-08MBSPP	3/8	1/2 - 14	32	1.25	62	2.44	27	1 1/16
V08-08MBSPP	1/2	1/2 - 14	33	1.10	66	2.63	27	1 1/16
V10-10MBSPP	5/8	5/8 - 14	35	1.37	71	2.79	30	1 3/16
V10-12MBSPP	5/8	3/4 - 14	36	1.41	72	2.83	32	1 1/4
V12-12MBSPP	3/4	3/4 - 14	38	1.49	89	3.50	32	1 1/4
V16-16MBSPP	1	1 - 11	45	1.77	101	3.97	41	1 5/8
V16-20MBSPP	1	1 1/4 - 11	48	1.88	104	4.09	50	2
VS20-20MBSPP	1 1/4	1 1/4 - 11	50	1.96	117	4.60	50	2
VS24-24MBSPP	1 1/2	1 1/2 - 11	55	2.16	138	5.43	55	2 1/4
VS32-32MBSPP	2	2 - 11	63	2.48	159	6.25	70	2 3/4

FBSPP BSPP FEMALE SWIVEL (60° SEAT)

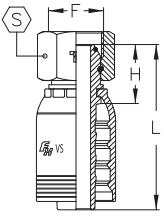

PART NUMBER	Hose Bore	F	H		L		S	
	INCH		[mm]	[in]	[mm]	[in]	[mm]	[in]
V06-06FBSPP	3/8	3/8 - 19	21	0.82	51	2.00	22	7/8
V06-08FBSPP	3/8	1/2 - 14	23	0.90	54	2.12	27	1 1/16
V08-08FBSPP	1/2	1/2 - 14	23	0.90	56	2.20	27	1 1/16
V08-10FBSPP	1/2	5/8 - 14	24	0.94	57	2.24	30	1 3/16
V10-10FBSPP	5/8	5/8 - 14	23	0.90	59	2.32	30	1 3/16
V10-12FBSPP	5/8	3/4 - 14	27	1.06	63	2.48	32	1 1/4
V12-12FBSPP	3/4	3/4 - 14	29	1.14	80	3.14	32	1 1/4
V12-16FBSPP	3/4	1 - 11	32	1.25	83	3.26	41	1 5/8
V16-16FBSPP	1	1 - 11	34	1.33	90	3.54	41	1 5/8
V16-20FBSPP	1	1 1/4 - 11	37	1.45	93	3.66	50	2
VS20-20FBSPP	1 1/4	1 1/4 - 11	39	1.53	106	4.17	50	2
VS24-24FBSPP	1 1/2	1 1/2 - 11	43	1.69	125	4.92	60	2 3/8
VS32-32FBSPP	2	2 - 11	47	1.85	143	5.62	75	3

FBSPP45 BSPP FEMALE SWIVEL - 45° ELBOW

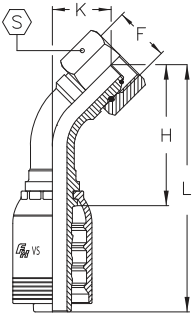

PART NUMBER	Hose Bore	F	H		L		K		S	
	INCH		[mm]	[in]	[mm]	[in]	[mm]	[in]	[mm]	[in]
V06-06FBSPP45	3/8	3/8 - 19	42	1.65	73	2.87	19	0.74	22	7/8
V08-08FBSPP45	1/2	1/2 - 14	49	1.92	82	3.22	22	0.86	27	1 1/16
V10-10FBSPP45	5/8	5/8 - 14	54	2.12	90	3.54	24	0.94	30	1 3/16
V10-12FBSPP45	5/8	3/4 - 14	57	2.24	93	3.66	26	1.02	32	1 1/4
V12-12FBSPP45	3/4	3/4 - 14	67	2.63	118	4.64	29	1.14	32	1 1/4
V12-16FBSPP45	3/4	1 - 11	67	2.63	118	4.64	29	1.14	41	1 5/8
V16-16FBSPP45	1	1 - 11	86	3.38	142	5.59	36	1.41	41	1 5/8
V16-20FBSPP45	1	1 1/4 - 11	86	3.38	142	5.59	36	1.41	50	2
VS20-20FBSPP45	1 1/4	1 1/4 - 11	103	4.05	169	6.65	43	1.69	50	2
VS24-24FBSPP45	1 1/2	1 1/2 - 11	123	4.84	206	8.11	51	2.00	60	2 3/8
VS32-32FBSPP45	2	2 - 11	160	6.29	257	10.11	65	2.55	75	3

Flextral Nut -12 & above

Reference Hose Section for Coupling Compatibility

COUPLINGS

FBSP90 BSPP FEMALE SWIVEL - 90° ELBOW

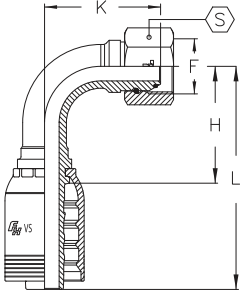

PART NUMBER	Hose Bore	F	H		L		K		S	
	INCH		[mm]	[in]	[mm]	[in]	[mm]	[in]	[mm]	[in]
V06-06FBSP90	3/8	3/8 - 19	31	1.22	61	2.40	35	1.37	22	7/8
V08-08FBSP90	1/2	1/2 - 14	37	1.46	70	2.75	42	1.65	27	1 1/16
V10-10FBSP90	5/8	5/8 - 14	45	1.77	80	3.15	46	1.81	30	1 3/16
V10-12FBSP90	5/8	3/4 - 14	45	1.77	80	3.15	50	1.97	32	1 1/4
V12-12FBSP90	3/4	3/4 - 14	55	2.16	106	4.17	57	2.24	32	1 1/4
V12-16FBSP90	3/4	1 - 11	55	2.16	106	4.17	57	2.24	41	1 5/8
V16-16FBSP90	1	1 - 11	71	2.79	128	5.03	72	2.83	41	1 5/8
V16-20FBSP90	1	1 1/4 - 11	71	2.79	128	5.03	72	2.83	50	2
VS20-20FBSP90	1 1/4	1 1/4 - 11	87	3.42	154	6.06	88	3.46	50	2
VS24-24FBSP90	1 1/2	1 1/2 - 11	105	4.13	188	7.40	104	4.09	60	2 3/8
VS32-32FBSP90	2	2 - 11	140	5.51	237	9.33	137	5.39	75	3

Flextral Nut -12 & above

MMS MALE METRIC HEAVY (24° SEAT) - CES

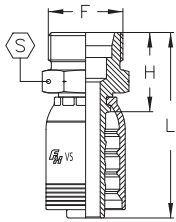

PART NUMBER	Hose Bore	F	Tube	H		L		S	
	INCH			[mm]	[in]	[mm]	[in]	[mm]	[in]
V06-20MMS	3/8	M20 x 1.5	S12	25	0.98	56	2.20	22	7/8
V06-22MMS	3/8	M22 x 1.5	S14	27	1.06	58	2.28	22	7/8
V08-24MMS	1/2	M24 x 1.5	S16	29	1.14	62	2.44	24	1
V10-30MMS	5/8	M30 x 2.0	S20	32	1.26	68	2.68	30	1 3/16
V12-30MMS	3/4	M30 x 2.0	S20	34	1.34	85	3.35	30	1 3/16
V12-36MMS	3/4	M36 x 2.0	S25	38	1.49	89	3.50	36	1 7/16
V16-36MMS	1	M36 x 2.0	S25	40	1.57	97	3.82	36	1 7/16
V16-42MMS	1	M42 x 2.0	S30	44	1.73	101	3.97	46	1 9/16
VS20-42MMS	1 1/4	M42 x 2.0	S30	47	1.85	113	4.45	46	1 9/16
VS20-52MMS	1 1/4	M52 x 2.0	S38	51	2.00	117	4.60	55	2 1/4
VS24-52MMS	1 1/2	M52 x 2.0	S38	53	2.08	135	5.31	55	2 1/4

FMS FEMALE METRIC HEAVY SWIVEL (24° SEAT) - DKOS

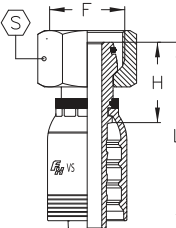

PART NUMBER	Hose Bore	F	Tube	H		L		S	
	INCH			[mm]	[in]	[mm]	[in]	[mm]	[in]
V06-18FMS	3/8	M18 x 1.5	S10	25	0.98	55	2.16	22	7/8
V06-20FMS	3/8	M20 x 1.5	S12	24	0.94	54	2.12	24	1
V06-22FMS	3/8	M22 x 1.5	S14	28	1.10	58	2.28	27	1 1/16
V08-22FMS	1/2	M22 x 1.5	S14	28	1.10	61	2.40	27	1 1/16
V08-24FMS	1/2	M24 x 1.5	S16	29	1.14	62	2.44	30	1 3/16
V10-30FMS	5/8	M30 x 2.0	S20	33	1.30	69	2.72	36	1 7/16
V12-30FMS	3/4	M30 x 2.0	S20	37	1.46	88	3.46	36	1 7/16
V12-36FMS	3/4	M36 x 2.0	S25	39	1.53	90	3.54	46	1 9/16
V16-36FMS	1	M36 x 2.0	S25	41	1.61	97	3.82	46	1 9/16
V16-42FMS	1	M42 x 2.0	S30	42	1.65	98	3.85	50	2
VS20-42FMS	1 1/4	M42 x 2.0	S30	43	1.69	109	4.29	50	2
VS20-52FMS	1 1/4	M52 x 2.0	S38	48	1.88	115	4.52	60	2 3/8
VS24-52FMS	1 1/2	M52 x 2.0	S38	51	2.00	133	5.23	60	2 3/8

Reference Hose Section for Coupling Compatibility

COUPLINGS

FMS45 FEMALE METRIC HEAVY SWIVEL (24° SEAT) - 45° ELBOW - DKOS

PART NUMBER	Hose Bore	F	Tube	H		L		K		⊕	
	INCH			[mm]	[in]	[mm]	[in]	[mm]	[in]	[mm]	[in]
V06-20FMS45	3/8	M20 x 1.5	S12	40	1.57	71	2.79	18	0.70	24	1
V06-22FMS45	3/8	M22 x 1.5	S14	42	1.65	72	2.83	19	0.75	27	1 1/16
V08-22FMS45	1/2	M22 x 1.5	S14	46	1.81	79	3.11	20	0.78	27	1 1/16
V08-24FMS45	1/2	M24 x 1.5	S16	47	1.85	80	3.14	21	0.82	30	1 3/16
V10-30FMS45	5/8	M30 x 2.0	S20	56	2.20	92	3.62	25	0.98	36	1 7/16
V12-30FMS45	3/4	M30 x 2.0	S20	65	2.56	116	4.57	27	1.06	36	1 7/16
V12-36FMS45	3/4	M36 x 2.0	S25	66	2.59	117	4.60	28	1.10	46	1 13/16
V16-36FMS45	1	M36 x 2.0	S25	83	3.27	140	5.51	34	1.34	46	1 13/16
V16-42FMS45	1	M42 x 2.0	S30	82	3.22	138	5.43	32	1.25	50	2
VS20-42FMS45	1 1/4	M42 x 2.0	S30	100	3.94	166	6.53	40	1.57	50	2
VS20-52FMS45	1 1/4	M52 x 2.0	S38	97	3.81	164	6.45	38	1.49	60	2 3/8
VS24-52FMS45	1 1/2	M52 x 2.0	S38	121	4.76	203	7.99	48	1.88	60	2 3/8

FMS90 FEMALE METRIC HEAVY SWIVEL (24° SEAT) - 90° ELBOW - DKOS

PART NUMBER	Hose Bore	F	Tube	H		L		K		⊕	
	INCH			[mm]	[in]	[mm]	[in]	[mm]	[in]	[mm]	[in]
V06-20FMS90	3/8	M20 x 1.5	S12	31	1.22	61	2.40	33	1.29	24	1
V06-22FMS90	3/8	M22 x 1.5	S14	34	1.33	64	2.51	37	1.45	27	1 1/16
V08-24FMS90	1/2	M24 x 1.5	S16	39	1.53	71	2.79	42	1.65	30	1 3/16
V10-30FMS90	5/8	M30 x 2.0	S20	44	1.73	80	3.15	49	1.93	36	1 7/16
V12-30FMS90	3/4	M30 x 2.0	S20	55	2.16	106	4.17	55	2.16	36	1 7/16
V12-36FMS90	3/4	M36 x 2.0	S25	55	2.16	106	4.17	55	2.16	46	1 13/16
V16-36FMS90	1	M36 x 2.0	S25	71	2.79	128	5.03	69	2.72	46	1 13/16
V16-42FMS90	1	M42 x 2.0	S30	71	2.79	128	5.03	67	2.63	50	2
VS20-42FMS90	1 1/4	M42 x 2.0	S30	87	3.42	154	6.06	83	3.27	50	2
VS20-52FMS90	1 1/4	M52 x 2.0	S38	87	3.42	154	6.06	80	3.14	60	2 3/8
VS24-52FMS90	1 1/2	M52 x 2.0	S38	105	4.13	188	7.40	100	3.93	60	2 3/8

Reference Hose Section for Coupling Compatibility

COUPLINGS

FL SAE CODE 61 FLANGE

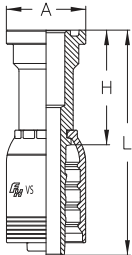

PART NUMBER	Hose Bore	FLANGE Thickness	A		H		L	
	INCH		[mm]	[in]	[mm]	[in]	[mm]	[in]
V08-08FL	1/2	0.265	30.2	1.19	48.5	1.91	81.5	3.21
V08-12FL	1/2	0.265	38.1	1.50	52.5	2.07	85.5	3.37
V10-12FL	5/8	0.265	38.1	1.50	52.5	2.07	88.5	3.84
V12-08FL	3/4	0.265	30.2	1.19	36.0	1.42	77.0	3.03
V12-12FL	3/4	0.265	38.1	1.50	55.0	2.16	106.0	4.17
V12-16FL	3/4	0.315	44.5	1.75	57.0	2.24	108.0	4.25
V12-20FL	3/4	0.315	50.8	2.00	55.0	2.16	106.0	4.17
V16-12FL	1	0.265	38.1	1.50	58.0	2.28	114.5	4.50
V16-16FL	1	0.315	44.5	1.75	58.0	2.28	114.5	4.50
V16-20FL	1	0.315	50.8	2.00	63.0	2.48	119.5	4.70
V16-24FL	1	0.315	60.4	2.38	55.0	2.16	115.5	4.55
VS20-16FL	1 1/4	0.315	44.5	1.75	64.0	2.51	130.5	5.14
VS20-20FL	1 1/4	0.315	50.8	2.00	64.0	2.51	130.5	5.14
VS20-24FL	1 1/4	0.315	60.4	2.38	68.0	2.67	134.5	5.29
VS20-32FL	1 1/4	0.375	71.4	2.81	75.0	2.95	141.5	5.57
VS24-24FL	1 1/2	0.315	60.4	2.38	73.0	2.87	155.5	6.12
VS24-32FL	1 1/2	0.375	71.4	2.38	76.0	2.87	158.5	6.12
VS32-32FL	2	0.375	71.4	2.81	77.0	3.03	176.5	6.95
VS32-40FL	2	0.375	84.1	3.31	90.0	3.54	186.5	7.34

FL22 SAE CODE 61 FLANGE - 22.5° ELBOW

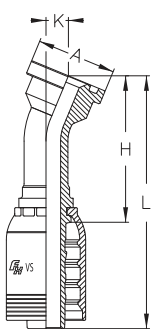

PART NUMBER	Hose Bore	FLANGE Thickness	A		H		L		K	
	INCH		[mm]	[in]	[mm]	[in]	[mm]	[in]	[mm]	[in]
V12-12FL22	3/4	0.265	38.1	1.50	70	2.75	121	4.76	11	0.43
V12-16FL22	3/4	0.315	44.5	1.75	73	2.87	124	4.88	12	0.47
V16-16FL22	1	0.315	44.5	1.75	86	3.38	142	5.59	12	0.47
V16-20FL22	1	0.315	50.8	2.00	86	3.38	142	5.59	12	0.47
VS20-20FL22	1 1/4	0.315	50.8	2.00	100	3.94	166	6.53	13	0.51
VS20-24FL22	1 1/4	0.315	60.4	2.38	100	3.94	166	6.53	13	0.51
VS24-24FL22	1 1/2	0.315	60.4	2.38	118	4.64	201	7.91	15	0.59
VS24-32FL22	1 1/2	0.375	71.4	2.81	116	4.57	199	7.83	14	0.55
VS32-32FL22	2	0.375	71.4	2.81	165	6.50	262	10.31	22	0.86

FL30 SAE CODE 61 FLANGE - 30° ELBOW

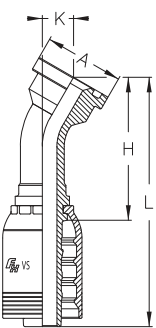

PART NUMBER	Hose Bore	FLANGE Thickness	A		H		L		K	
	INCH		[mm]	[in]	[mm]	[in]	[mm]	[in]	[mm]	[in]
V12-12FL30	3/4	0.265	38.1	1.50	68	2.68	119	4.68	16	0.63
V12-16FL30	3/4	0.315	44.5	1.75	71	2.79	122	4.80	17	0.67
V16-16FL30	1	0.315	44.5	1.75	84	3.31	140	5.51	17	0.67
V16-20FL30	1	0.315	50.8	2.00	84	3.31	140	5.51	17	0.67
VS20-20FL30	1 1/4	0.315	50.8	2.00	98	3.86	164	6.46	19	0.75
VS20-24FL30	1 1/4	0.315	60.4	2.38	98	3.86	164	6.46	19	0.75
VS24-24FL30	1 1/2	0.315	60.4	2.38	116	4.57	199	7.83	22	0.87
VS24-32FL30	1 1/2	0.375	71.4	2.81	114	4.49	197	7.75	21	0.83
VS32-32FL30	2	0.375	71.4	2.81	162	6.38	258	10.16	31	1.22

Reference Hose Section for Coupling Compatibility

COUPLINGS

FL45 SAE CODE 61 FLANGE - 45° ELBOW

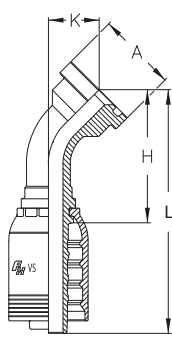

PART NUMBER	Hose Bore	FLANGE Thickness	A		H		L		K	
	INCH		[mm]	[in]	[mm]	[in]	[mm]	[in]	[mm]	[in]
V08-08FL45	1/2	0.265	30.2	1.19	62.0	2.44	95.0	3.74	22.5	0.89
V08-12FL45	1/2	0.265	38.1	1.50	66.0	2.60	99.0	3.90	27.0	1.06
V10-12FL45	5/8	0.265	38.1	1.50	79.5	3.13	115.5	4.55	27.5	1.08
V12-12FL45	3/4	0.265	38.1	1.50	63.0	2.48	114.0	4.48	25.0	0.98
V12-16FL45	3/4	0.265	44.5	1.75	65.0	2.55	116.0	4.56	27.0	1.06
V16-16FL45	1	0.315	44.5	1.75	78.0	3.07	134.0	5.27	28.0	1.10
V16-20FL45	1	0.315	50.8	2.00	78.0	3.07	134.0	5.27	28.0	1.10
VS20-16FL45	1 1/4	0.315	44.5	1.75	96.0	3.78	163.0	6.42	37.0	1.46
VS20-20FL45	1 1/4	0.315	50.8	2.00	91.0	3.58	157.0	6.18	32.0	1.25
VS20-24FL45	1 1/4	0.315	60.4	2.38	91.0	3.58	157.0	6.18	32.0	1.25
VS24-24FL45	1 1/2	0.315	60.4	2.38	108.0	4.25	191.0	7.51	36.0	1.41
VS24-32FL45	1 1/2	0.375	71.4	2.81	107.0	4.21	189.0	7.44	35.0	1.37
VS32-32FL45	2	0.375	71.4	2.81	151.0	5.94	245.0	9.64	57.0	2.24

FL60 SAE CODE 61 FLANGE - 60° ELBOW

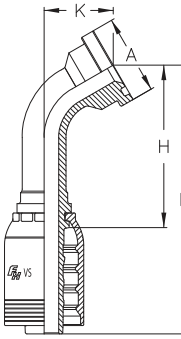

PART NUMBER	Hose Bore	FLANGE Thickness	A		H		L		K	
	INCH		[mm]	[in]	[mm]	[in]	[mm]	[in]	[mm]	[in]
V12-12FL60	3/4	0.265	38.1	1.50	77	3.03	128	5.04	34	1.34
V12-16FL60	3/4	0.315	44.5	1.75	79	3.11	130	5.12	37	1.46
V16-16FL60	1	0.315	44.5	1.75	98	3.86	154	6.06	40	1.57
V16-20FL60	1	0.315	50.8	2.00	98	3.86	154	6.06	40	1.57
VS20-20FL60	1 1/4	0.315	50.8	2.00	118	4.64	184	7.24	45	1.77
VS20-24FL60	1 1/4	0.315	60.4	2.38	118	4.64	184	7.24	45	1.77
VS24-24FL60	1 1/2	0.315	60.4	2.38	140	5.51	223	8.78	52	2.05
VS24-32FL60	1 1/2	0.375	71.4	2.81	139	5.47	222	8.74	50	1.97
VS32-32FL60	2	0.375	71.4	2.81	192	7.56	289	11.38	73	2.87

FL67 SAE CODE 61 FLANGE - 67.5° ELBOW

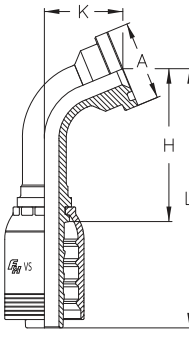

PART NUMBER	Hose Bore	FLANGE Thickness	A		H		L		K	
	INCH		[mm]	[in]	[mm]	[in]	[mm]	[in]	[mm]	[in]
V12-12FL67	3/4	0.265	38.1	1.50	72	2.83	123	4.84	39	1.53
V12-16FL67	3/4	0.315	44.5	1.75	73	2.87	124	4.88	41	1.61
V16-16FL67	1	0.315	44.5	1.75	92	3.62	148	5.83	45	1.77
V16-20FL67	1	0.315	50.8	2.00	92	3.62	148	5.83	45	1.77
VS20-20FL67	1 1/4	0.315	50.8	2.00	111	4.37	178	7.01	52	2.05
VS20-24FL67	1 1/4	0.315	60.4	2.38	111	4.37	178	7.01	52	2.05
VS24-24FL67	1 1/2	0.315	60.4	2.38	133	5.24	216	8.50	60	2.36
VS24-32FL67	1 1/2	0.375	71.4	2.81	132	5.20	215	8.46	58	2.28
VS32-32FL67	2	0.375	71.4	2.81	181	7.12	278	10.94	84	3.31

Reference Hose Section for Coupling Compatibility

COUPLINGS

FL90

SAE CODE 61 FLANGE - 90° ELBOW

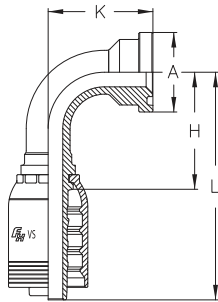

PART NUMBER	Hose Bore	FLANGE Thickness	A		H		L		K	
	INCH		[mm]	[in]	[mm]	[in]	[mm]	[in]	[mm]	[in]
V08-08FL90-042	1/2	0.265	30.2	1.19	41	1.61	74	2.91	42	1.65
V08-08FL90-083	1/2	0.265	30.2	1.19	41	1.61	74	2.91	83	3.27
V08-12FL90-047	1/2	0.265	38.1	1.50	41	1.61	74	2.91	47	1.85
V10-12FL90-052	5/8	0.265	38.1	1.50	49	1.93	85	3.35	52	2.05
V12-12FL90-051	3/4	0.265	38.1	1.50	55	2.16	106	4.17	51	2.00
V12-12FL90-096	3/4	0.265	38.1	1.50	55	2.16	106	4.17	96	3.77
V12-12FL90-127	3/4	0.265	38.1	1.50	55	2.16	106	4.17	127	5.00
V12-16FL90-055	3/4	0.315	44.5	1.75	55	2.16	106	4.17	55	2.16
V12-16FL90-079	3/4	0.315	44.5	1.75	55	2.16	106	4.17	79	3.11
V12-20FL90-060	3/4	0.315	50.8	2.00	55	2.16	106	4.17	60	2.36
V16-16FL90-061	1	0.315	44.5	1.75	71	2.79	128	5.03	61	2.40
V16-16FL90-118	1	0.315	44.5	1.75	71	2.79	128	5.03	118	4.64
V16-20FL90-061	1	0.315	50.8	2.00	71	2.79	128	5.03	61	2.40
V16-20FL90-118	1	0.315	50.8	2.00	71	2.79	128	5.03	118	4.64
V16-24FL90-061	1	0.315	60.4	2.38	71	2.79	128	5.03	61	2.40
VS20-16FL90-079	1 1/4	0.315	44.5	1.75	87	3.42	154	6.06	79	3.11
VS20-20FL90-071	1 1/4	0.315	50.8	2.00	87	3.42	154	6.06	71	2.79
VS20-20FL90-091	1 1/4	0.315	50.8	2.00	87	3.42	154	6.06	91	3.58
VS20-20FL90-102	1 1/4	0.315	50.8	2.00	87	3.42	154	6.06	102	4.01
VS20-20FL90-112	1 1/4	0.315	50.8	2.00	87	3.42	154	6.06	112	4.40
VS20-20FL90-130	1 1/4	0.315	50.8	2.00	87	3.42	154	6.06	130	5.11
VS20-20FL90-168	1 1/4	0.315	50.8	2.00	87	3.42	154	6.06	168	6.61
VS20-24FL90-071	1 1/4	0.315	60.4	2.38	87	3.42	154	6.06	71	2.79
VS20-24FL90-118	1 1/4	0.315	60.4	2.38	87	3.42	154	6.06	118	4.64
VS20-24FL90-130	1 1/4	0.315	60.4	2.38	87	3.42	154	6.06	130	5.11
VS24-20FL90-090	1 1/2	0.315	50.8	2.00	98	3.85	180	7.09	90	3.54
VS24-24FL90-083	1 1/2	0.315	60.4	2.38	105	4.13	188	7.40	83	3.26
VS24-24FL90-148	1 1/2	0.315	60.4	2.38	105	4.13	188	7.40	148	5.82
VS24-24FL90-172	1 1/2	0.315	60.4	2.38	105	4.13	188	7.40	172	6.77
VS24-32FL90-081	1 1/2	0.375	71.4	2.81	105	4.13	188	7.40	81	3.18
VS24-32FL90-115	1 1/2	0.375	71.4	2.81	105	4.13	188	7.40	115	4.52
VS24-32FL90-172	1 1/2	0.375	71.4	2.81	105	4.13	188	7.40	172	6.77
VS32-32FL90-122	2	0.375	71.4	2.81	140	5.51	237	9.33	122	4.80
VS32-32FL90-165	2	0.375	71.4	2.81	140	5.51	237	9.33	165	6.49
VS32-32FL90-203	2	0.375	71.4	2.81	140	5.51	237	9.33	203	7.99
VS32-40FL90-117	2	0.375	84.1	3.31	140	5.51	237	9.33	117	4.60

Reference Hose Section for Coupling Compatibility

COUPLINGS

FL100 SAE CODE 61 FLANGE - 100° ELBOW

	PART NUMBER	Hose Bore	FLANGE Thickness	A		H		L		K	
		INCH		[mm]	[in]	[mm]	[in]	[mm]	[in]	[mm]	[in]
	V12-12FL100	3/4	0.265	38.1	1.50	61	2.40	112	4.41	59	2.32

FL110 SAE CODE 61 FLANGE - 110° ELBOW

	PART NUMBER	Hose Bore	FLANGE Thickness	A		H		L		K	
		INCH		[mm]	[in]	[mm]	[in]	[mm]	[in]	[mm]	[in]
	V12-12FL110	3/4	0.265	38.1	1.50	51	2.01	102	4.01	62	2.44
V16-16FL110	1	0.315	44.5	1.75	65	2.56	121	4.76	73	2.87	
V16-20FL110	1	0.315	50.8	2.00	65	2.56	121	4.76	73	2.87	
VS20-20FL110	1 1/4	0.315	50.8	2.00	82	3.23	148	5.83	83	3.27	
VS20-24FL110	1 1/4	0.315	60.4	2.38	82	3.23	148	5.83	83	3.27	
VS24-24FL110	1 1/2	0.315	60.4	2.38	95	3.74	178	7.01	97	3.82	
VS32-32FL110	2	0.375	71.4	2.81	124	4.88	220	8.66	142	5.59	

LET SAE CODE 61 CAPTIVE FLANGE - 5000 PSI

	PART NUMBER	Hose Bore	A		H		L	
		INCH	[mm]	[in]	[mm]	[in]	[mm]	[in]
	VS20-20LET	1 1/4	50.8	2.00	111.8	4.40	178.6	7.03
VS24-24LET	1 1/2	60.3	2.37	129.6	5.10	212.1	8.35	
VS32-32LET	2	71.4	2.81	139.5	5.49	236.0	9.29	

LET45 SAE CODE 61 CAPTIVE FLANGE - 5000 PSI

	PART NUMBER	Hose Bore	A		H		L		K	
		INCH	[mm]	[in]	[mm]	[in]	[mm]	[in]	[mm]	[in]
	VS20-20LET45-063	1 1/4	50.8	2.00	122.5	4.82	189.0	7.44	63.0	2.48
VS24-24LET45-074	1 1/2	60.3	2.37	146.5	5.77	229.0	9.02	74.0	2.91	

Reference Hose Section for Coupling Compatibility

COUPLINGS

LET90

SAE CODE 61 CAPTIVE FLANGE – 5000 PSI

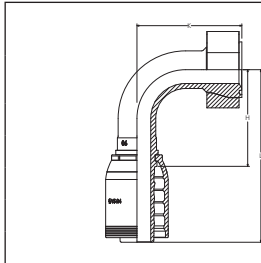

PART NUMBER	Hose Bore	A		H		L		K	
	INCH	[mm]	[in]	[mm]	[in]	[mm]	[in]	[mm]	[in]
VS20-20LET90-102	1¼	50.8	2.00	87.5	3.44	154.0	6.06	102	4.02
VS24-24LET90-114	1½	60.3	2.37	105.1	4.13	187.6	7.39	114	4.49
VS32-32LET90-136	2	71.4	2.81	150.3	5.92	247.0	9.72	136	5.35

FLH

SAE CODE 62 FLANGE

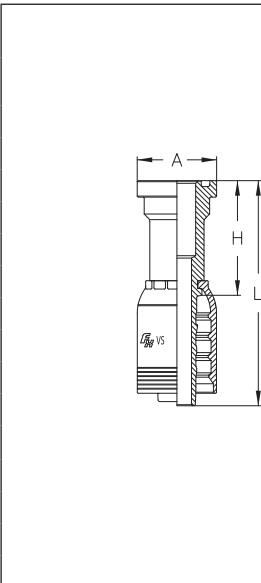

PART NUMBER	Hose Bore	FLANGE Thickness	A		H		L	
	INCH		[mm]	[in]	[mm]	[in]	[mm]	[in]
V08-08FLH	½	0.305	31.7	1.25	49.5	1.95	82.5	3.25
V08-12FLH	½	0.345	41.3	1.62	52.5	2.07	89.0	3.50
V10-12FLH	5/8	0.345	41.3	1.62	59.5	2.34	95.5	3.76
V12-12FLH	¾	0.345	41.3	1.62	59	2.32	110.0	4.33
V12-16FLH	¾	0.375	47.6	1.87	61	2.40	112.0	4.40
V16-12FLH	1	0.345	41.3	1.62	65	2.56	121.5	4.78
V16-16FLH	1	0.375	47.6	1.87	65	2.56	121.5	4.78
V16-20FLH	1	0.405	54.0	2.12	69	2.71	125.5	4.94
VS20-16FLH	1¼	0.375	47.6	1.87	70	2.75	136.5	5.37
VS20-20FLH	1¼	0.405	54.0	2.12	70	2.75	136.5	5.37
VS20-24FLH	1¼	0.495	63.5	2.50	80	3.14	146.5	5.76
VS24-20FLH	1½	0.405	54.0	2.13	84	3.31	166.5	6.56
VS24-24FLH	1½	0.495	63.5	2.50	84	3.31	166.5	6.56
VS24-32FLH	1½	0.495	79.4	3.12	99	3.89	181.5	7.14
VS32-32FLH	2	0.495	79.4	3.12	100	3.93	196.5	7.73

FLH22

SAE CODE 62 FLANGE - 22.5° ELBOW

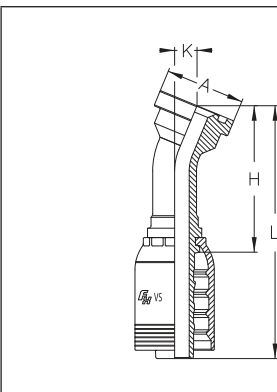

PART NUMBER	Hose Bore	FLANGE Thickness	A		H		L		K	
	INCH		[mm]	[in]	[mm]	[in]	[mm]	[in]	[mm]	[in]
V12-12FLH22	¾	0.345	41.3	1.62	74	2.91	125	4.92	13	0.51
V12-16FLH22	¾	0.375	47.6	1.87	76	2.99	127	5.00	14	0.55
V16-16FLH22	1	0.375	47.6	1.87	89	3.50	145	5.70	13	0.51
V16-20FLH22	1	0.405	54.0	2.12	89	3.50	145	5.70	13	0.51
VS20-20FLH22	1¼	0.405	54.0	2.12	103	4.05	169	6.65	15	0.59
VS20-24FLH22	1¼	0.495	63.5	2.50	104	4.09	171	6.73	15	0.59
VS24-24FLH22	1½	0.495	63.5	2.50	123	4.84	206	8.11	17	0.66
VS24-32FLHLS	1½	0.495	79.4	3.12	127	5.00	210	8.26	19	0.74
VS32-32FLHLS	2	0.495	79.4	3.12	166	6.53	263	10.35	24	0.94

Reference Hose Section for Coupling Compatibility

COUPLINGS

FLH30 SAE CODE 62 FLANGE - 30° ELBOW

PART NUMBER	Hose Bore	FLANGE Thickness	A		H		L		K	
	INCH		[mm]	[in]	[mm]	[in]	[mm]	[in]	[mm]	[in]
	V12-12FLH30		3/4	0.345	41.3	1.62	72	2.83	123	4.84
V12-16FLH30	3/4	0.375	47.6	1.87	74	2.91	125	4.92	19	0.74
V16-16FLH30	1	0.375	47.6	1.87	87	3.42	143	5.62	19	0.74
V16-20FLH30	1	0.405	54.0	2.12	87	3.42	143	5.62	19	0.74
VS20-20FLH30	1 1/4	0.405	54.0	2.12	100	3.93	167	6.57	20	0.78
VS20-24FLH30	1 1/4	0.495	63.5	2.50	102	4.01	168	6.61	21	0.82
VS24-24FLH30	1 1/2	0.495	63.5	2.50	121	4.76	203	7.99	24	0.94
VS24-32FLH30	1 1/2	0.495	79.4	3.12	124	4.88	207	8.14	26	1.02
VS32-32FLH30	2	0.495	79.4	3.12	162	6.37	259	10.19	34	1.33

FLH45 SAE CODE 62 FLANGE - 45° ELBOW

PART NUMBER	Hose Bore	FLANGE Thickness	A		H		L		K	
	INCH		[mm]	[in]	[mm]	[in]	[mm]	[in]	[mm]	[in]
	V08-08FLH45		1/2	0.305	31.7	1.25	63.0	2.48	96.0	3.78
V08-12FLH45	1/2	0.345	41.3	1.62	68.5	2.70	101.5	4.00	29.0	1.14
V10-12FLH45	5/8	0.345	41.3	1.62	81.5	3.21	117.5	4.63	29.5	1.16
V12-12FLH45	3/4	0.345	41.3	1.62	66	2.59	117	4.60	28	1.10
V12-16FLH45	3/4	0.375	47.6	1.87	68	2.67	118	4.64	29	1.14
V16-12FLH45	1	0.345	41.3	1.62	81	3.18	137	5.39	31	1.22
V16-16FLH45	1	0.375	47.6	1.87	80	3.14	136	5.35	30	1.18
V16-20FLH45	1	0.405	54.0	2.12	80	3.14	136	5.35	30	1.18
VS20-16FLH45	1 1/4	0.375	47.6	1.87	96	3.77	163	6.41	37	1.45
VS20-20FLH45	1 1/4	0.405	54.0	2.12	93	3.66	160	6.29	34	1.33
VS20-24FLH45	1 1/4	0.495	63.5	2.50	94	3.70	161	6.33	35	1.37
VS24-24FLH45	1 1/2	0.495	63.5	2.50	112	4.40	195	7.67	40	1.57
VS24-32FLH45	1 1/2	0.495	79.4	3.12	115	4.52	198	7.79	43	1.69
VS32-32FLH45	2	0.495	79.4	3.12	150	5.90	247	9.72	56	2.20

FLH60 SAE CODE 62 FLANGE - 60° ELBOW

PART NUMBER	Hose Bore	FLANGE Thickness	A		H		L		K	
	INCH		[mm]	[in]	[mm]	[in]	[mm]	[in]	[mm]	[in]
	V16-16FLH60		1	0.375	47.6	1.87	99	3.89	155	6.10
V20-20FLH60	1 1/4	0.405	54.0	2.12	119	4.68	185	7.28	47	1.85
V24-24FLH60	1 1/2	0.495	63.5	2.50	143	5.62	225	8.85	56	2.20
V32-32FLH60	2	0.495	79.4	3.12	193	7.59	289	11.37	79	3.11

Reference Hose Section for Coupling Compatibility

COUPLINGS

FLH67

SAE CODE 62 FLANGE - 67.5° ELBOW

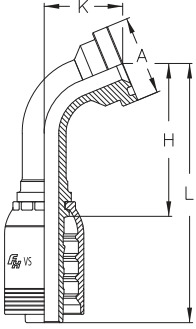

PART NUMBER	Hose Bore	FLANGE Thickness	A		H		L		K	
	INCH		[mm]	[in]	[mm]	[in]	[mm]	[in]	[mm]	[in]
V16-16FLH67	1	0.375	47.6	1.87	93	3.66	150	5.90	48	1.88
VS20-20FLH67	1¼	0.405	54.0	2.12	112	4.40	179	7.04	54	2.12
VS24-24FLH67	1½	0.495	63.5	2.50	135	5.31	217	8.54	65	2.55
VS32-32FLH67	2	0.495	79.4	3.12	182	7.16	278	10.94	90	3.54

FLH90

SAE CODE 62 FLANGE - 90° ELBOW

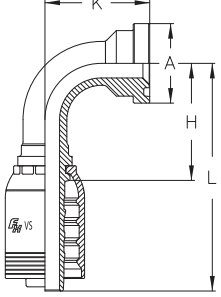

PART NUMBER	Hose Bore	FLANGE Thickness	A		H		L		K	
	INCH		[mm]	[in]	[mm]	[in]	[mm]	[in]	[mm]	[in]
V08-08FLH90-042	½	0.305	31.7	1.25	41	1.61	74	2.91	42	1.65
V08-12FLH90-050	½	0.345	41.3	1.62	41	1.61	74	2.91	50	1.97
V10-12FLH90-055	5/8	0.345	41.3	1.62	49	1.93	85	3.35	55	2.17
V12-12FLH90-056	¾	0.345	41.3	1.62	55	2.16	106	4.17	56	2.20
V12-12FLH90-100	¾	0.345	41.3	1.62	55	2.16	106	4.17	100	3.93
V12-16FLH90-058	¾	0.375	47.6	1.87	55	2.16	106	4.17	58	2.28
V12-16FLH90-140	¾	0.375	47.6	1.87	55	2.16	106	4.17	140	5.51
V16-12FLH90-065	1	0.345	41.3	1.62	71	2.79	128	5.03	65	2.55
V16-16FLH90-064	1	0.375	47.6	1.87	71	2.79	128	5.03	64	2.51
V16-16FLH90-120	1	0.375	47.6	1.87	71	2.79	128	5.03	120	4.72
V16-20FLH90-064	1	0.405	54.0	2.12	71	2.79	128	5.03	64	2.51
VS20-16FLH90-079	1¼	0.375	47.6	1.87	87	3.42	154	6.06	79	3.11
VS20-20FLH90-074	1¼	0.405	54.0	2.12	87	3.42	154	6.06	74	2.91
VS20-20FLH90-120	1¼	0.405	54.0	2.12	87	3.42	154	6.06	120	4.72
VS20-24FLH90-076	1¼	0.495	63.5	2.50	87	3.42	154	6.06	76	2.99
VS24-20FLH90-064	1½	0.405	54.0	2.13	87	3.43	154	6.06	64	2.52
VS24-24FLH90-088	1½	0.495	63.5	2.50	105	4.13	188	7.40	88	3.46
VS24-32FLH90-093	1½	0.495	79.4	3.12	105	4.13	188	7.40	93	3.66
VS24-24FLH90-108	1½	0.495	63.5	2.50	105	4.13	188	7.40	108	4.25
VS24-24FLH90-114	1½	0.495	63.5	2.50	105	4.13	187.5	7.38	114	4.49
VS24-24FLH90-198	1½	0.495	63.5	2.50	105	4.13	187.5	7.38	198	7.80
VS32-32FLH90-123	2	0.495	79.4	3.12	140	5.51	237	9.33	123	4.84

Reference Hose Section for Coupling Compatibility

COUPLINGS

FLC CATERPILLAR® FLANGE

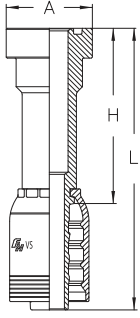

Use with D-Rings

PART NUMBER	Hose Bore	FLANGE Thickness	A		H		L	
	INCH		[mm]	[in]	[mm]	[in]	[mm]	[in]
V12-12FLC	3/4	0.560	41.3	1.62	84	3.30	135	5.31
V12-16FLC	3/4	0.560	47.6	1.87	84	3.30	135	5.31
V16-16FLC	1	0.560	47.6	1.87	90	3.54	146.5	5.76
V16-20FLC	1	0.560	54.0	2.12	90	3.54	146.5	5.76
VS20-20FLC	1 1/4	0.560	54.0	2.12	88	3.46	154.4	6.07
VS20-24FLC	1 1/4	0.560	63.5	2.50	88	3.46	154.5	6.08
VS24-24FLC	1 1/2	0.560	63.5	2.50	84	3.30	166.5	6.55
VS24-32FLC	1 1/2	0.560	79.4	3.12	110	4.33	192.5	7.57
VS32-32FLC	2	0.560	79.4	3.12	130	5.11	226.5	8.91

FLC22 CATERPILLAR® FLANGE - 22.5° ELBOW

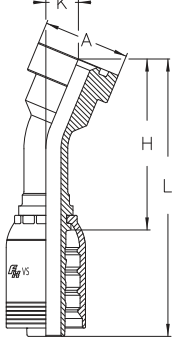

Use with D-Rings

PART NUMBER	Hose Bore	FLANGE Thickness	A		H		L		K	
	INCH		[mm]	[in]	[mm]	[in]	[mm]	[in]	[mm]	[in]
V12-12FLC22	3/4	0.560	41.3	1.62	82	3.22	133	5.23	16	0.62
V12-16FLC22	3/4	0.560	47.6	1.87	84	3.30	135	5.31	17	0.66
V16-16FLC22	1	0.560	47.6	1.87	97	3.81	153	6.02	17	0.66
V16-20FLC22	1	0.560	54.0	2.12	97	3.81	153	6.02	17	0.66
VS20-20FLC22	1 1/4	0.560	54.0	2.12	106	4.17	172	6.77	16	0.62
VS20-24FLC22	1 1/4	0.560	63.5	2.50	106	4.17	174	6.85	16	0.62
VS24-24FLC22	1 1/2	0.560	63.5	2.50	125	4.92	208	8.18	18	0.70
VS24-32FLC22	1 1/2	0.560	79.4	3.12	129	5.07	211	8.30	19	0.74
VS32-32FLC22	2	0.560	79.4	3.12	168	6.61	265	10.43	25	0.98

FLC30 CATERPILLAR® FLANGE - 30° ELBOW

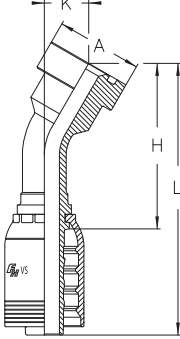

Use with D-Rings

PART NUMBER	Hose Bore	FLANGE Thickness	A		H		L		K	
	INCH		[mm]	[in]	[mm]	[in]	[mm]	[in]	[mm]	[in]
V12-12FLC30	3/4	0.560	41.3	1.62	79	3.11	130	5.11	22	0.86
V12-16FLC30	3/4	0.560	47.6	1.87	82	3.22	133	5.23	23	0.90
V16-16FLC30	1	0.560	47.6	1.87	94	3.70	151	5.94	23	0.90
V16-20FLC30	1	0.560	54.0	2.12	94	3.70	151	5.94	23	0.90
VS20-20FLC30	1 1/4	0.560	54.0	2.12	103	4.05	170	6.69	22	0.86
VS20-24FLC30	1 1/4	0.560	63.5	2.50	104	4.09	170	6.69	23	0.90
VS24-24FLC30	1 1/2	0.560	63.5	2.50	123	4.84	205	8.07	25	0.98
VS24-32FLC30	1 1/2	0.560	79.4	3.12	126	4.96	208	8.18	27	1.06
VS32-32FLC30	2	0.560	79.4	3.12	164	6.45	264	10.39	35	1.37

Reference Hose Section for Coupling Compatibility

COUPLINGS

FLC45

CATERPILLAR® FLANGE - 45° ELBOW

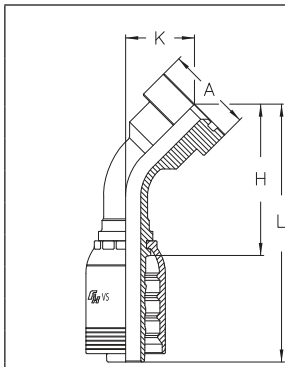

Use with D-Rings

PART NUMBER	Hose Bore	FLANGE Thickness	A		H		L		K	
	INCH		[mm]	[in]	[mm]	[in]	[mm]	[in]	[mm]	[in]
V12-12FLC45	3/4	0.560	41.3	1.62	72	2.83	123	4.84	34	1.33
V12-16FLC45	3/4	0.560	47.6	1.87	74	2.91	125	4.92	36	1.41
V16-16FLC45	1	0.560	47.6	1.87	86	3.38	143	5.62	36	1.41
V16-20FLC45	1	0.560	54.0	2.12	86	3.38	143	5.62	36	1.41
VS20-20FLC45	1 1/4	0.560	54.0	2.12	96	3.77	162	6.37	36	1.41
VS20-24FLC45	1 1/4	0.560	63.5	2.50	96	3.77	162	6.37	36	1.41
VS24-24FLC45	1 1/2	0.560	63.5	2.50	114	4.48	196	7.71	41	1.61
VS24-32FLC45	1 1/2	0.560	79.4	3.12	116	4.56	199	7.83	44	1.73
VS32-32FLC45	2	0.560	79.4	3.12	152	5.98	250	9.84	57	2.24

FLC60

CATERPILLAR® FLANGE - 60° ELBOW

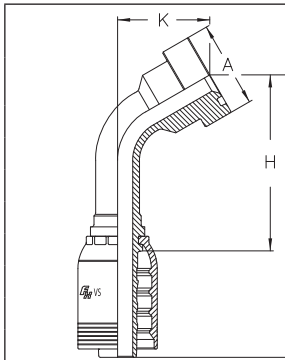

Use with D-Rings

PART NUMBER	Hose Bore	FLANGE Thickness	A		H		L		K	
	INCH		[mm]	[in]	[mm]	[in]	[mm]	[in]	[mm]	[in]
V12-12FLC60	3/4	0.560	41.3	1.62	83	3.26	134	5.27	45	1.77
V12-16FLC60	3/4	0.560	47.6	1.87	85	3.34	136	5.35	48	1.88
V16-16FLC60	1	0.560	47.6	1.87	103	4.05	160	6.29	50	1.96
V16-20FLC60	1	0.560	54.0	2.12	103	4.05	160	6.29	50	1.96
VS20-20FLC60	1 1/4	0.560	54.0	2.12	121	4.76	187	7.36	50	1.96
VS20-24FLC60	1 1/4	0.560	63.5	2.50	121	4.76	187	7.36	51	2.00
VS24-24FLC60	1 1/2	0.560	63.5	2.50	144	5.66	226	8.89	58	2.28
VS24-32FLC60	1 1/2	0.560	79.4	3.12	146	5.74	228	8.97	61	2.40
VS32-32FLC60	2	0.560	79.4	3.12	194	7.63	290	11.41	81	3.18

FLC67

CATERPILLAR® FLANGE - 67.5° ELBOW

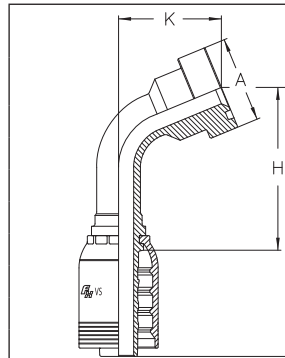

Use with D-Rings

PART NUMBER	Hose Bore	FLANGE Thickness	A		H		L		K	
	INCH		[mm]	[in]	[mm]	[in]	[mm]	[in]	[mm]	[in]
V12-12FLC67	3/4	0.560	41.3	1.62	77	3.03	128	5.03	50	1.96
V12-16FLC67	3/4	0.560	47.6	1.87	79	3.11	130	5.11	53	2.08
V16-16FLC67	1	0.560	47.6	1.87	97	3.81	153	6.02	56	2.20
V16-20FLC67	1	0.560	54.0	2.12	97	3.81	153	6.02	56	2.20
VS20-20FLC67	1 1/4	0.560	54.0	2.12	114	4.48	181	7.12	57	2.24
VS20-24FLC67	1 1/4	0.560	63.5	2.50	114	4.48	181	7.12	58	2.28
VS24-24FLC67	1 1/2	0.560	63.5	2.50	137	5.39	219	8.62	66	2.59
VS24-32FLC67	1 1/2	0.560	79.4	3.12	138	5.43	220	8.66	69	2.71
VS32-32FLC67	2	0.560	79.4	3.12	184	7.24	280	11.02	92	3.62

Reference Hose Section for Coupling Compatibility

COUPLINGS

FLC90 CATERPILLAR® FLANGE - 90° ELBOW

PART NUMBER	Hose Bore	FLANGE Thickness	A		H		L		K	
	INCH		[mm]	[in]	[mm]	[in]	[mm]	[in]	[mm]	[in]
V12-12FLC90-064	3/4	0.560	41.3	1.62	55	2.16	106	4.17	64	2.51
V12-12FLC90-129	3/4	0.560	41.3	1.62	55	2.16	106	4.17	129	5.07
V12-16FLC90-064	3/4	0.560	47.6	1.87	55	2.16	106	4.17	64	2.51
V16-16FLC90-073	1	0.560	47.6	1.87	71	2.79	128	5.03	73	2.87
V16-16FLC90-132	1	0.560	47.6	1.87	71	2.79	128	5.03	132	5.19
V16-16FLC90-150	1	0.560	47.6	1.87	71	2.79	128	5.03	150	5.90
V16-20FLC90-073	1	0.560	54.0	2.12	71	2.79	128	5.03	73	2.87
VS20-20FLC90-077	1 1/4	0.560	54.0	2.12	87	3.42	154	6.06	77	3.03
VS20-20FLC90-150	1 1/4	0.560	54.0	2.12	87	3.42	154	6.06	150	5.90
VS20-24FLC90-078	1 1/4	0.560	63.5	2.50	87	3.42	154	6.06	78	3.07
VS20-24FLC90-135	1 1/4	0.560	63.5	2.50	87	3.42	154	6.06	135	5.31
VS24-24FLC90-090	1 1/2	0.560	63.5	2.50	105	4.13	188	7.40	90	3.54
VS24-24FLC90-106	1 1/2	0.560	63.5	2.50	105	4.13	188	7.40	106	4.17
VS24-32FLC90-094	1 1/2	0.560	79.4	3.12	105	4.13	188	7.40	94	3.70
VS32-32FLC90-125	2	0.560	79.4	3.12	140	5.51	237	9.33	125	4.92

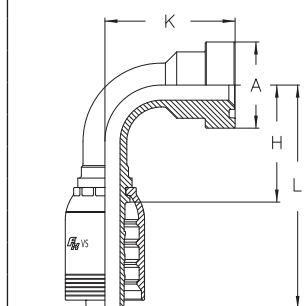

Use with D-Rings

FLOKA O&K® FLANGE

PART NUMBER	Hose Bore	FLANGE Thickness	A		H		L	
	INCH		[mm]	[in]	[mm]	[in]	[mm]	[in]
V16-20FLOKA-STR	1	0.433	57.4	2.26	116.5	4.59	173	6.81
VS20-20FLOKA-STR	1 1/4	0.433	57.4	2.26	118.5	4.67	185	7.28
VS24-24FLOKA-STR	1 1/2	0.518	68.4	2.69	107.5	4.23	190	7.48

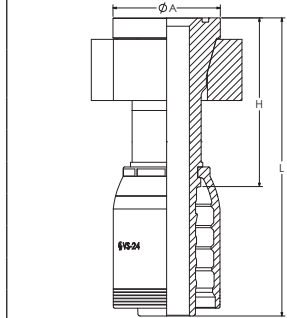

FLOKA22 O&K® FLANGE - 22° ELBOW

PART NUMBER	Hose Bore	FLANGE Thickness	A		H		L		K	
	INCH		[mm]	[in]	[mm]	[in]	[mm]	[in]	[mm]	[in]
VS24-24FLOKA22-036	1 1/2	0.518	68.4	2.69	188.5	7.42	271	10.67	36	1.42

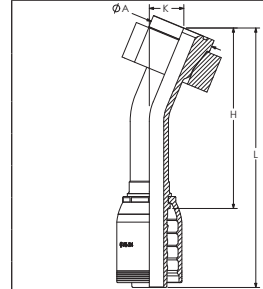

Reference Hose Section for Coupling Compatibility

COUPLINGS

FLOKA45 O&K® FLANGE - 45° ELBOW

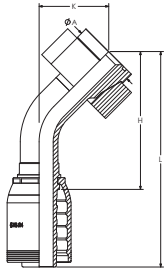
	PART NUMBER	Hose Bore	A		H		L		K	
		INCH	[mm]	[in]	[mm]	[in]	[mm]	[in]	[mm]	[in]
	VS20-20FLOKA45-063	1¼	57.4	2.26	138	5.43	204.5	8.06	63	2.48
	VS20-24FLOKA45-066	1¼	68.4	2.69	125	4.92	191.5	7.54	67	2.62
	VS24-24FLOKA45-074	1½	68.4	2.69	147	5.77	229.0	9.02	74	2.91
	VS24-32FLOKA45-080	1½	83.4	3.28	150	5.91	232.5	9.15	80	3.15

FLOKA90 O&K® FLANGE - 90° ELBOW

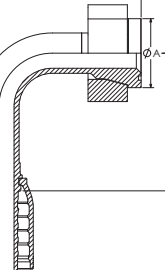
	PART NUMBER	Hose Bore	A		H		L		K	
		INCH	[mm]	[in]	[mm]	[in]	[mm]	[in]	[mm]	[in]
	VS16-20FLOKA90-100	1	57.4	2.26	97.5	3.84	154	6.06	100	4.80
	VS20-20FLOKA90-122	1¼	57.4	2.26	122.5	4.82	189	7.44	122	4.80
	VS24-24FLOKA90-141	1½	68.4	2.69	136.5	5.37	219	8.62	141	5.55
	VS24-32FLOKA90-160	1½	83.4	3.28	126.5	4.98	209	8.22	160	6.29

OKBR FLOKA CRIMP STRAIN RELIEF SLEEVE

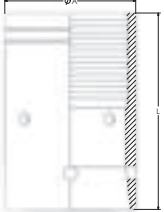
	PART NUMBER	Hose Bore	A		L	
		INCH	[mm]	[in]	[mm]	[in]
	20OKBR	1¼	60.0	2.36	90.0	3.54
	24OKBR	1½	73.0	2.87	105.0	4.13
	32OKBR	2	95.0	3.74	120.0	4.72

Reference Hose Section for Coupling Compatibility

COUPLINGS

1901 SPLIT FLANGE KIT (CODE 61)

	PART NUMBER	SIZE
	1901-08-K	1/2
	1901-12-K	3/4
	1901-16-K	1
	1901-20-K	1 1/4
	1901-24-K	1 1/2
	1901-32-K	2

1902 SPLIT FLANGE KIT (CODE 62)

	PART NUMBER	SIZE
	1902-08-K	1/2
	1902-12-K	3/4
	1902-16-K	1
	1902-20-K	1 1/4
	1902-24-K	1 1/2
	1902-32-K	2

1903 CATERPILLAR® SPLIT FLANGE KIT

	PART NUMBER	SIZE
	1903-12-K	3/4
	1903-16-K	1
	1903-20-K	1 1/4
	1903-24-K	1 1/2
	1903-32-K	2

Reference Hose Section for Coupling Compatibility

COUPLINGS

FERRULE

	PART NUMBER	Hose Bore	A		L	
		INCH	[mm]	[in]	[mm]	[in]
	C32	2	88.0	3.46	130	5.12

FLH SAE CODE 62 FLANGE

	PART NUMBER	Hose Bore	FLANGE THICKNESS		A		H		L	
		INCH	[mm]	[in]	[mm]	[in]	[mm]	[in]	[mm]	[in]
	C32-32FLH	2	12.6	.495	79.4	3.12	110	4.33	262	10.31

Note: C Series couplings are external skive only.

FLH45 SAE CODE 62 FLANGE - 45° ELBOW

	PART NUMBER	Hose Bore	FLANGE THICKNESS		A		H		L		K	
		INCH	[mm]	[in]	[mm]	[in]	[mm]	[in]	[mm]	[in]	[mm]	[in]
	C32-32FLH45	2	12.6	.495	79.4	3.12	147	5.78	299	11.77	56	2.20

Note: C Series couplings are external skive only.

FLH90 SAE CODE 62 FLANGE - 90° ELBOW

	PART NUMBER	Hose Bore	FLANGE THICKNESS		A		H		L		K	
		INCH	[mm]	[in]	[mm]	[in]	[mm]	[in]	[mm]	[in]	[mm]	[in]
	C32-32FLH90	2	12.6	.495	79.4	3.12	176	6.92	328	12.91	164	6.45

Note: C Series couplings are external skive only.

Reference Hose Section for Coupling Compatibility

COUPLINGS

FLC SAE CODE 62 FLANGE

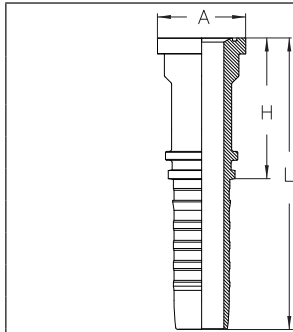

Use with D-Rings

Note: C Series couplings are external skive only.

PART NUMBER	Hose Bore	FLANGE THICKNESS		A		H		L	
	INCH	[mm]	[in]	[mm]	[in]	[mm]	[in]	[mm]	[in]
C32-32FLC	2	12.6	.495	79.4	3.12	126	4.96	262	10.31

FLC45 SAE CODE 62 FLANGE - 45° ELBOW

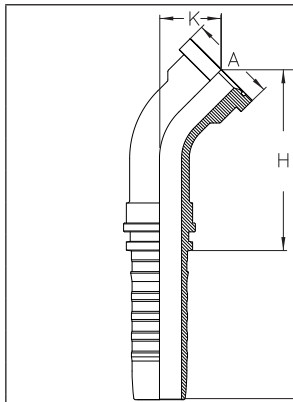

Use with D-Rings

Note: C Series couplings are external skive only.

PART NUMBER	Hose Bore	FLANGE THICKNESS		A		H		L		K	
	INCH	[mm]	[in]	[mm]	[in]	[mm]	[in]	[mm]	[in]	[mm]	[in]
C32-32FLC45	2	12.6	.495	79.4	3.12	170	6.69	135	5.31	66	2.60

FLC90 SAE CODE 62 FLANGE - 90° ELBOW

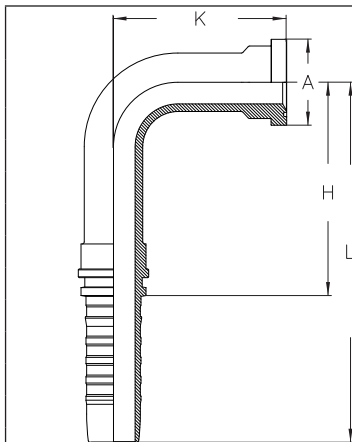

Use with D-Rings

Note: C Series couplings are external skive only.

PART NUMBER	Hose Bore	FLANGE THICKNESS		A		H		L		K	
	INCH	[mm]	[in]	[mm]	[in]	[mm]	[in]	[mm]	[in]	[mm]	[in]
C32-32FLC90	2	12.6	.495	79.4	3.12	197	7.75	332	13.07	160	6.30

COUPLINGS

FLOKA

O&K® FLANGE

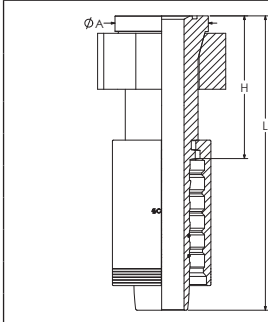

PART NUMBER	Hose Bore	FLANGE Thickness	A		H		L	
	INCH		[mm]	[in]	[mm]	[in]	[mm]	[in]
C32-32FLOKA-STR	2	0.551	83.4	3.28	127.5	5.02	263	10.35

Note: C Series couplings are external skive only.

FLOKA22

O&K® FLANGE - 22° ELBOW

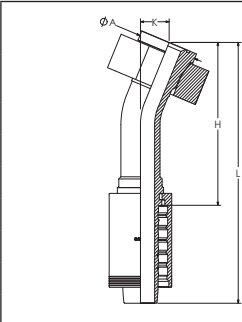

PART NUMBER	Hose Bore	FLANGE Thickness	A		H		L		K	
	INCH		[mm]	[in]	[mm]	[in]	[mm]	[in]	[mm]	[in]
C32-32FLOKA22-040	2	0.551	83.4	3.28	224.5	8.84	360	14.17	50	1.57

Note: C Series couplings are external skive only.

FLOKA45

O&K® FLANGE - 45° ELBOW

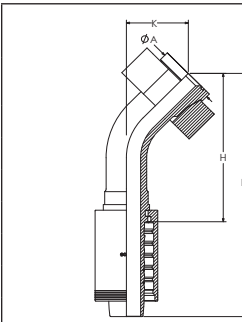

PART NUMBER	Hose Bore	FLANGE Thickness	A		H		L		K	
	INCH		[mm]	[in]	[mm]	[in]	[mm]	[in]	[mm]	[in]
C32-32FLOKA45-087	2	0.551	83.4	3.28	212	8.35	347.5	13.68	87	3.43

Note: C Series couplings are external skive only.

Reference Hose Section for Coupling Compatibility

COUPLINGS

FLOKA90 O&K® FLANGE - 90° ELBOW

	PART NUMBER	Hose Bore	FLANGE Thickness	A		H		L		K	
		INCH		[mm]	[in]	[mm]	[in]	[mm]	[in]	[mm]	[in]
	C32-32FLOKA90-175	1½	0.551	83.4	3.28	167.5	6.59	303	11.93	175	6.89

Note: C Series couplings are external skive only.

OKBR FLOKA CRIMP STRAIN RELIEF SLEEVE

	PART NUMBER	Hose Bore	A		L	
		INCH	[mm]	[in]	[mm]	[in]
	20OKBR	1¼	60.0	2.36	90.0	3.54
24OKBR	1½	73.0	2.87	105.0	4.13	
32OKBR	2	95.0	3.74	120.0	4.72	

COUPLINGS

FL SAE CODE 61 FLANGE

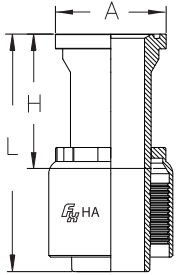

PART NUMBER	Hose Bore	FLANGE THICKNESS		A		H		L	
	INCH	[mm]	[in]	[mm]	[in]	[mm]	[in]	[mm]	[in]
HA32-40FL	2	9.5	.375	84.1	3.31	76	2.99	124	4.88
HA40-40FL	2½	9.5	.375	84.1	3.31	81	3.20	147	5.78
HA40-48FL	2½	9.5	.375	101.6	4.00	84	3.30	148	5.84
HA40-64FL	2½	11.2	.442	127.0	5.00	89	3.52	155	6.09
HA48-48FL	3	9.5	.375	101.6	4.00	65	2.54	122	4.81
HA48-56FL	3	11.2	.442	114.3	4.50	72	2.85	131	5.17
HA56-56FL	3½	11.2	.442	114.3	4.50	69	2.72	149	5.88
HA64-64FL	4	11.2	.442	127.0	5.00	88	3.48	184	7.23

FL22 SAE CODE 61 FLANGE - 22.5° ELBOW

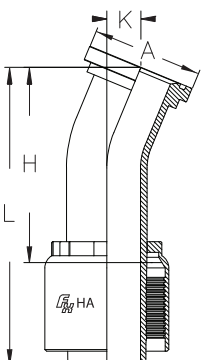

PART NUMBER	Hose Bore	FLANGE THICKNESS		A		H		L		K	
	INCH	[mm]	[in]	[mm]	[in]	[mm]	[in]	[mm]	[in]	[mm]	[in]
HA40-40FL22	2½	9.5	.375	84.1	3.31	113	4.46	179	7.03	18	0.72

FL30 SAE CODE 61 FLANGE - 30° ELBOW

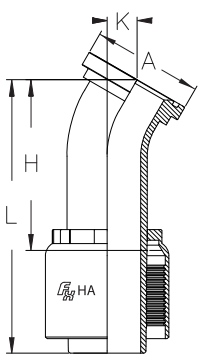

PART NUMBER	Hose Bore	FLANGE THICKNESS		A		H		L		K	
	INCH	[mm]	[in]	[mm]	[in]	[mm]	[in]	[mm]	[in]	[mm]	[in]
HA40-40FL30	2½	9.5	.375	84.1	3.31	122	4.80	187	7.38	27	1.06
HA48-48FL30	2½	9.5	.375	101.6	4.00	123	4.86	189	7.43	27	1.06

Reference Hose Section for Coupling Compatibility

COUPLINGS

FL45 SAE CODE 61 FLANGE - 45° ELBOW

PART NUMBER	Hose Bore	FLANGE THICKNESS		A		H		L		K	
	INCH	[mm]	[in]	[mm]	[in]	[mm]	[in]	[mm]	[in]	[mm]	[in]
	HA32-40FL45	2	9.5	.375	84.1	3.31	147	5.80	195	7.69	52
HA40-40FL45	2½	9.5	.375	84.1	3.31	136	5.35	201	7.91	47	1.87
HA40-48FL45	2½	9.5	.375	101.6	4.00	137	5.40	202	7.97	47	1.87
HA48-48FL45	3	9.5	.375	101.6	4.00	187	7.35	255	10.05	67	2.65
HA48-56FL45	3	11.2	.442	114.3	4.50	188	7.42	248	9.75	67	2.65
HA56-56FL45	3½	11.2	.442	114.3	4.50	220	8.67	300	11.83	73	2.88

FL60 SAE CODE 61 FLANGE - 60° ELBOW

PART NUMBER	Hose Bore	FLANGE THICKNESS		A		H		L		K	
	INCH	[mm]	[in]	[mm]	[in]	[mm]	[in]	[mm]	[in]	[mm]	[in]
	HA40-40FL60	2½	9.5	.375	84.1	3.31	169	6.65	229	9.00	71
HA40-48FL60	2½	9.5	.375	101.6	4.00	168	6.61	230	9.06	71	2.78

FL90 SAE CODE 61 FLANGE - 90° ELBOW

PART NUMBER	Hose Bore	FLANGE THICKNESS		A		H		L		K	
	INCH	[mm]	[in]	[mm]	[in]	[mm]	[in]	[mm]	[in]	[mm]	[in]
	HA32-40FL90	2	9.5	.375	84.1	3.31	143	5.62	191	7.51	114
HA40-40FL90	2½	9.5	.375	84.1	3.31	141	5.55	2.05	8.09	119	4.69
HA40-48FL90	2½	9.5	.375	101.6	4.00	141	5.55	207	8.15	119	4.69
HA48-48FL90	3	9.5	.375	101.6	4.00	201	7.91	260	10.24	162	6.38
HA48-56FL90	3	11.2	.442	114.3	4.50	200	7.89	260	10.24	162	6.38
HA56-56FL90	3½	11.2	.442	114.3	4.50	227	8.94	302	11.88	178	7.00
HA64-64FL90	4	11.2	.442	127.0	5.00	193	7.60	289	11.36	187	7.38

Reference Hose Section for Coupling Compatibility

COUPLINGS

MP NPT MALE

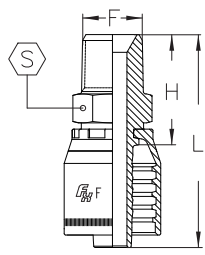

PART NUMBER	Hose Bore	F	H		L		S	
	INCH		[mm]	[in]	[mm]	[in]	[mm]	[in]
F04-02MP	3/16	1/8 - 27	20.6	0.81	45.6	1.79	12	1/2
F04-04MP	3/16	1/4 - 18	26.5	1.04	51.5	2.02	14	9/16
F05-04MP	1/4	1/4 - 18	27.0	1.06	55.0	2.16	14	9/16
F06-04MP	5/16	1/4 - 18	27.0	1.06	55.0	2.16	14	9/16
F06-06MP	5/16	3/8 - 18	28.6	1.12	56.6	2.22	19	3/4
F08-06MP	13/32	3/8 - 18	33.1	1.30	57.5	2.26	19	3/4
F08-08MP	13/32	1/2 - 14	39.1	1.53	63.5	2.50	22	7/8
F10-08MP	1/2	1/2 - 14	35.0	1.37	68.0	2.67	22	7/8
F10-12MP	1/2	3/4 - 12	36.9	1.45	69.9	2.75	27	1 1/16
F12-12MP	5/8	3/4 - 12	37.1	1.46	72.9	2.87	27	1 1/16
F16-16MP	7/8	3/4 - 12	49.0	1.92	82.9	3.26	36	1 7/16
F20-20MP	1 1/8	1 1/4 - 11 1/2	50.3	1.98	103.6	4.08	43	1 3/4
F24-24MP	1 3/16	3/4 - 12	58.0	2.28	110.0	4.33	50	2
F32-32MP	2	2 - 11 1/2	63.0	2.50	123.0	4.84	65	2 9/16

MJ JIC 37° MALE

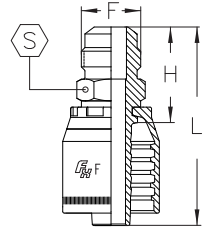

PART NUMBER	Hose Bore	F	H		L		S	
	INCH		[mm]	[in]	[mm]	[in]	[mm]	[in]
F04-04MJ	3/16	7/16 - 20	25.0	0.98	50.0	1.96	12	1/2
F05-05MJ	1/4	1/2 - 20	25.5	1.00	53.5	2.10	14	9/16
F05-06MJ	1/4	9/16 - 18	26.6	1.04	54.6	2.14	15	5/8
F06-06MJ	5/16	9/16 - 18	26.6	1.04	54.6	2.14	15	5/8
F08-08MJ	13/32	3/4 - 16	36.6	1.44	61.0	2.40	22	7/8
F10-08MJ	1/2	3/4 - 16	30.7	1.20	63.7	2.50	19	3/4
F10-10MJ	1/2	7/8 - 14	35.3	1.38	68.3	2.68	24	1
F12-12MJ	5/8	1 1/16 - 12	39.1	1.53	74.9	2.94	27	1 1/16

FJ JIC 37° FEMALE SWIVEL

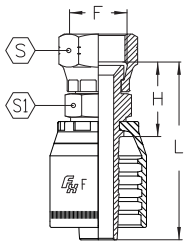

PART NUMBER	Hose Bore	F	H		L		S		S1	
	INCH		[mm]	[in]	[mm]	[in]	[mm]	[in]	[mm]	[in]
F04-04FJ	3/16	7/16 - 20	19.0	0.74	44.0	1.73	14	9/16	12	1/2
F05-04FJ	1/4	7/16 - 20	20.5	0.80	48.5	1.90	14	9/16	14	9/16
F05-05FJ	1/4	1/2 - 20	21.0	0.82	49.0	1.92	17	1 1/16	14	9/16
F05-06FJ	1/4	9/16 - 18	22.0	0.86	50.0	1.96	19	3/4	14	9/16
F06-06FJ	5/16	9/16 - 18	22.5	0.88	50.5	1.98	19	3/4	16	5/8
F06-08FJ*	5/16	3/4 - 16	17.5	0.68	45.5	1.79	22	7/8	-	-
F08-08FJ	13/32	3/4 - 16	31.1	1.22	64.6	2.54	24	15/16	19	3/4
F10-08FJ	1/2	3/4 - 16	25.5	1.00	58.5	2.30	22	7/8	19	3/4
F10-10FJ	1/2	7/8 - 14	27.5	1.08	60.5	2.38	27	1 1/16	22	7/8
F10-12FJ	1/2	1 1/16 - 12	30.3	1.19	63.3	2.49	32	1 1/4	25	1
F12-12FJ	5/8	1 1/16 - 12	30.5	1.20	66.3	2.61	32	1 1/4	25	1
F16-16FJ	7/8	1 5/16 - 12	35.5	1.39	76.0	2.99	38	1 1/2	32	1 1/4
F20-20FJ	1 1/8	1 5/16 - 12	53.4	2.10	105.0	4.13	50	2	41	1 5/8
F24-24FJ	1 3/8	1 7/8 - 12	60.0	2.36	120.0	4.72	57	2 1/4	50	2
F32-32FJ	2	2 1/2 - 12	51.5	2.03	111.5	4.39	70	2 3/4	60	2 3/8

* Single hexagon coupling.

Reference Hose Section for Coupling Compatibility

COUPLINGS

FJ45 JIC 37° FEMALE SWIVEL - 45° ELBOW

PART NUMBER	Hose Bore	F	H		L		K		S	
	INCH		[mm]	[in]	[mm]	[in]	[mm]	[in]	[mm]	[in]
	F04-04FJ45		3/16	7/16 - 20	29	1.14	54	2.12	10	0.39
F05-05FJ45	1/4	1/2 - 20	32	1.25	60	2.36	11	0.43	17	1 1/16
F06-06FJ45	5/16	9/16 - 18	34	1.33	62	2.44	12	0.47	19	3/4
F08-08FJ45	13/32	3/4 - 16	45	1.77	78	3.07	20	0.78	24	15/16
F10-10FJ45	1/2	7/8 - 14	43	1.69	76	2.99	16	0.62	27	1 1/16
F12-12FJ45	5/8	1 1/16 - 12	50	1.96	86	3.38	19	0.74	32	1 1/4
F16-16FJ45	7/8	1 5/16 - 16	98	3.87	140	5.49	36	1.41	38	1 1/2

FJ90S JIC 37° FEMALE SWIVEL - 90° ELBOW SHORT DROP

PART NUMBER	Hose Bore	F	H		L		K		S	
	INCH		[mm]	[in]	[mm]	[in]	[mm]	[in]	[mm]	[in]
	F10-10FJ90S		1/2	7/8 - 14	38.0	1.50	71.0	2.79	33	1.30
F12-12FJ90S	5/8	1 1/16 - 12	30	1.20	66.3	2.61	40	1.57	32	1 1/4

FJ90M JIC 37° FEMALE SWIVEL - 90° ELBOW MEDIUM DROP

PART NUMBER	Hose Bore	F	H		L		K		S	
	INCH		[mm]	[in]	[mm]	[in]	[mm]	[in]	[mm]	[in]
	F04-04FJ90M		3/16	7/16 - 20	21.0	0.82	46	1.81	21.0	0.82
F05-05FJ90M	1/4	7/16 - 20	25.5	1.00	53.5	2.10	26.0	1.02	14	9/16
F05-06FJ90M	1/4	9/16 - 18	25.5	1.00	53.5	2.10	27.0	1.06	19	3/4
F06-06FJ90M	5/16	9/16 - 18	28.0	1.10	56	2.20	29.0	1.14	19	3/4
F08-08FJ90M	13/32	3/4 - 16	31.6	1.24	69.5	2.73	39.0	1.53	24	15/16
F10-10FJ90M	1/2	7/8 - 14	37.0	1.45	70	2.75	40.0	1.57	27	1 1/16
F10-12FJ90M	1/2	1 1/16 - 12	40.0	1.57	73	2.87	40.0	1.57	32	1 1/4
F12-12FJ90M	5/8	1 1/16 - 12	45.0	1.77	81	3.18	47.0	1.85	32	1 1/4
F16-16FJ90M	7/8	1 5/16 - 12	74.0	2.91	129	5.07	72.0	2.83	38	1 1/2
F20-20FJ90M	1 1/16	1 5/8 - 12	89.1	3.50	147	5.78	88.4	3.48	50	2

FJ90L JIC 37° FEMALE SWIVEL - 90° ELBOW LONG DROP

PART NUMBER	Hose Bore	F	H		L		K		S	
	INCH		[mm]	[in]	[mm]	[in]	[mm]	[in]	[mm]	[in]
	F16-16FJ90L		7/8	1 5/16 - 12	74.0	2.91	115	4.52	116.0	4.56
F20-20FJ90L	1 1/16	1 5/8 - 12	89.1	3.50	147	5.78	145.0	5.70	50	2

Reference Hose Section for Coupling Compatibility

COUPLINGS

FF90S

ORFS FEMALE SWIVEL - 90° ELBOW SHORT DROP

PART NUMBER	Hose Bore	F	H		L		K		S	
	INCH		[mm]	[in]	[mm]	[in]	[mm]	[in]	[mm]	[in]
F06-06FF90S	5/16	1 1/16 - 16	29.0	1.14	57.0	2.24	25.0	0.98	22	7/8
F10-08FF90S	1/2	1 3/16 - 16	39.0	1.54	72.0	2.83	31.0	1.20	24	1
F10-10FF90S	1/2	1 - 14	39.0	1.54	72.0	2.83	34.0	1.34	30	1 3/16
F12-12FF90S	5/8	1 - 14	45.0	1.77	81.0	3.19	42.0	1.65	30	1 3/16

MA

SAE 45° MALE

PART NUMBER	Hose Bore	F	H		L		S	
	INCH		[mm]	[in]	[mm]	[in]	[mm]	[in]
F06-06MA	5/16	5/8 - 18	28.2	1.11	56.2	2.21	16	5/8

FA

SAE 45° FEMALE SWIVEL

PART NUMBER	Hose Bore	F	H		L		S		S1	
	INCH		[mm]	[in]	[mm]	[in]	[mm]	[in]	[mm]	[in]
F06-06FA	5/16	5/8 - 18	23.5	0.92	51.5	2.02	22	7/8	16	5/8
F12-12FA	5/8	1 1/16 - 14	31.8	1.25	72.3	2.84	32	1 1/4	27	1 1/16

FA45

SAE 45° FEMALE SWIVEL - 45° ELBOW

PART NUMBER	Hose Bore	F	H		L		K		S	
	INCH		[mm]	[in]	[mm]	[in]	[mm]	[in]	[mm]	[in]
F06-06FA45	5/16	5/8 - 18	38	1.49	66	2.59	16	0.62	22	7/8

FA90

SAE 45° FEMALE SWIVEL - 90° ELBOW

PART NUMBER	Hose Bore	F	H		L		K		S	
	INCH		[mm]	[in]	[mm]	[in]	[mm]	[in]	[mm]	[in]
F06-06FA90	5/16	5/8 - 18	28	1.10	56	2.20	29	1.14	22	7/8

Reference Hose Section for Coupling Compatibility

COUPLINGS

MP NPT MALE

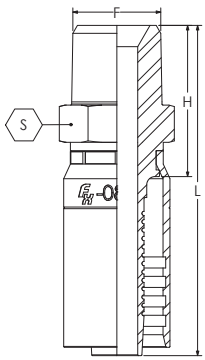
	PART NUMBER	Hose Bore	F	H		L		S	
		INCH		[mm]	[in]	[mm]	[in]	[mm]	[in]
									
P02-02MP	1/8	1/8 - 27	19.1	0.75	32.8	1.29	12.7	1/2	
P02-04MP	1/8	1/8 - 18	23.9	0.94	37.6	1.48	15.9	5/8	
P03-02MP	3/16	1/8 - 27	26.9	1.06	47.5	1.87	14.3	9/16	
P03-04MP	3/16	1/4 - 18	31.8	1.25	52.3	2.06	17.5	11/16	
P03-06MP	3/16	3/8 - 18	35.1	1.38	54.6	2.15	19.1	3/4	
P04-02MP	1/4	1/8 - 27	25.4	1	53.8	2.12	15.9	5/8	
P04-04MP	1/4	1/4 - 18	30.2	1.19	58.7	2.31	17.5	11/16	
P04-06MP	1/4	3/8 - 18	33.3	1.31	61.0	2.40	19.1	3/4	
P05-04MP	5/16	1/4 - 18	30.2	1.19	58.7	2.31	17.5	11/16	
P05-06MP	5/16	3/8 - 18	31.8	1.25	61.0	2.40	19.1	3/4	
P06-04MP	3/8	1/4 - 18	33.3	1.31	65.8	2.59	19.7	3/4	
P06-06MP	3/8	3/8 - 18	33.3	1.31	65.8	2.59	19.1	3/4	
P06-08MP	3/8	1/2 - 14	36.6	1.44	59.4	2.34	23.8	15/16	
P08-06MP	1/2	3/8 - 18	33.3	1.31	70.6	2.78	22.2	7/8	
P08-08MP	1/2	1/2 - 14	38.1	1.50	77.0	3.03	23.8	15/16	
P12-12MP	3/4	3/4 - 11 1/2	41.4	1.63	81.5	3.21	28.6	1 1/8	
P16-16MP	1	1 - 11 1/2	47.8	1.88	100.6	3.96	34.9	1 3/8	

MPX NPT MALE SWIVEL

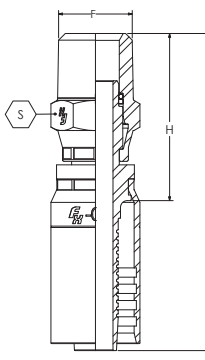
	PART NUMBER	Hose Bore	F	H		L		S	
		INCH		[mm]	[in]	[mm]	[in]	[mm]	[in]
									
P02-02MPX	1/8	1/8 - 27	49.3	1.94	48.3	1.90	12.7	1/2	
P03-04MPX	1/4	1/4 - 18	46.0	1.81	67.1	2.64	17.5	11/16	
P04-04MPX	1/4	1/4 - 18	46.0	1.81	73.2	2.88	17.5	11/16	
P05-04MPX	3/8	1/4 - 18	44.5	1.75	73.2	2.88	17.5	11/16	
P06-06MPX	3/8	3/8 - 18	49.3	1.94	80.5	3.17	19.0	3/4	
P06-08MPX	3/8	1/2 - 14	54.1	2.13	85.3	3.36	22.2	7/8	
P08-08MPX	1/2	1/2 - 14	54.1	2.13	91.7	3.61	23.8	15/16	
P12-12MPX	3/4	3/4 - 14	55.6	2.19	98.0	3.86	28.6	1 1/8	
P16-16MPX	1	1 - 11 1/2	66.8	2.63	118.6	4.67	38.1	1 1/2	

Reference Hose Section for Coupling Compatibility

COUPLINGS

FP NPT FEMALE RIGID

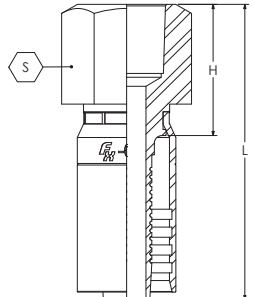

PART NUMBER	Hose Bore	F	H		L		S	
	INCH		[mm]	[in]	[mm]	[in]	[mm]	[in]
P04-04FP	1/4	1/4 - 18	31.8	1.25	59.4	2.34	19.0	3/4
P04-06FP	1/4	3/8 - 18	33.3	1.31	61.8	2.43	22.2	7/8
P06-06FP	3/8	3/8 - 18	35.1	1.38	66.6	2.62	22.2	7/8
P08-08FP	1/2	1/2 - 14	38.1	1.50	75.3	2.96	27.0	1 1/16

FPX NPSM FEMALE SWIVEL (60° CONE SEAT)

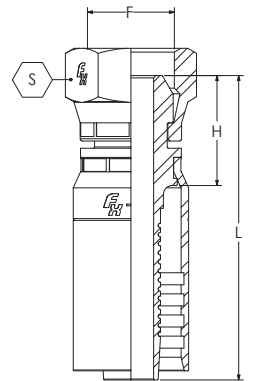

PART NUMBER	Hose Bore	F	H		L		S	
	INCH		[mm]	[in]	[mm]	[in]	[mm]	[in]
P02-04FPX	1/8	1/4 - 18	26.9	1.06	41.9	1.65	17.5	1 1/16
P03-04FPX	1/8	1/4 - 18	33.3	1.31	54.2	2.13	19.1	3/4
P04-05FPX	1/4	1/4 - 18	33.3	1.31	60.6	2.38	19.1	3/4
P04-06FPX	1/4	3/8 - 18	35.1	1.38	62.6	2.46	22.2	7/8
P05-04FPX	1/8	1/4 - 18	36.6	1.44	64.5	2.54	19.1	3/4
P06-04FPX	3/8	1/4 - 18	36.6	1.44	67.7	2.67	19.1	3/4
P06-06FPX	3/8	3/8 - 18	30.2	1.19	67.4	2.65	22.2	7/8
P08-08FPX	1/2	1/2 - 14	38.1	1.50	75.9	2.99	25.4	1
P12-12FPX	3/4	3/4 - 14	44.5	1.75	87.2	3.43	31.8	1 1/4
P16-16FPX	1	1 - 11 1/2	47.8	1.88	103.1	4.06	1.5	1 1/2

MJ JIC 37° MALE

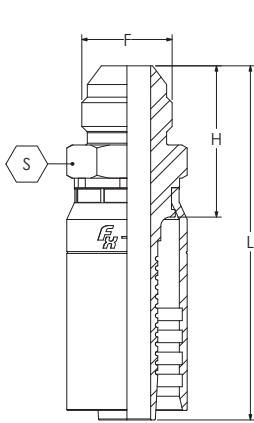

PART NUMBER	Hose Bore	F	H		L		S	
	INCH		[mm]	[in]	[mm]	[in]	[mm]	[in]
P03-03MJ	3/8	3/8 - 24	30.2	1.19	50.1	1.97	14.3	9/16
P03-04MJ	3/16	7/16 - 20	31.8	1.25	51.9	2.05	14.3	9/16
P04-04MJ	1/4	7/16 - 20	31.8	1.25	58.3	2.30	15.9	5/8
P04-05MJ	1/4	1/2 - 20	31.8	1.25	58.3	2.30	15.9	5/8
P04-06MJ	1/4	9/16 - 18	33.3	1.31	60.8	2.40	19.1	3/4
P05-05MJ	5/16	1/2 - 20	30.2	1.19	58.3	2.30	15.9	5/8
P05-06MJ	5/16	9/16 - 18	30.2	1.19	58.4	2.30	17.5	1 1/16
P06-06MJ	3/8	9/16 - 18	33.3	1.31	65.6	2.58	19.0	3/4
P06-08MJ	3/8	3/4 - 16	36.6	1.44	68.2	2.68	20.6	13/16
P08-08MJ	1/2	3/4 - 16	35.1	1.38	72.9	2.87	22.2	7/8
P08-10MJ	1/2	7/8 - 14	39.6	1.56	77.9	3.04	23.8	15/16
P08-12MJ	1/2	1 1/16 - 12	41.4	1.63	79.8	3.14	28.6	1 1/8
P12-12MJ	3/4	1 1/16 - 12	41.4	1.63	84.5	3.33	28.6	1 1/8
P16-16MJ	1	1 5/16 - 12	47.8	1.88	100.0	3.94	34.9	1 3/8

Reference Hose Section for Coupling Compatibility

COUPLINGS

FJ45

JIC 37° FEMALE SWIVEL - 45° ELBOW

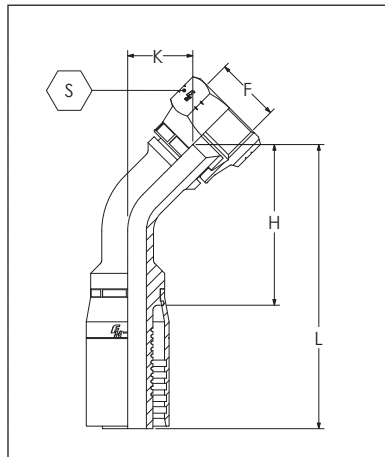

PART NUMBER	Hose Bore	F	H		L		K		S	
	INCH		[mm]	[in]	[mm]	[in]	[mm]	[in]	[mm]	[in]
P03-04FJ45	3/16	7/16 - 20	38.1	1.50	58.4	2.30	11.9	0.47	14.3	9/16
P04-04FJ45	1/4	7/16 - 20	38.1	1.50	64.8	2.55	11.9	0.47	14.3	9/16
P04-05FJ45	1/4	1/2 - 20	39.6	1.56	67.1	2.64	13.5	0.53	15.9	5/8
P04-06FJ45	1/4	9/16 - 18	41.4	1.63	69.3	2.73	15.0	0.59	17.5	11/16
P05-06FJ45	5/16	9/16 - 18	41.4	1.63	69.3	2.73	15.0	0.59	17.5	11/16
P06-06FJ45	3/8	9/16 - 18	42.9	1.69	74.2	2.92	15.0	0.59	17.5	11/16
P06-08FJ45	3/8	3/4 - 16	47.8	1.88	78.7	3.10	18.0	0.71	22.2	7/8
P08-08FJ45	1/2	3/4 - 16	46.0	1.81	83.3	3.28	18.0	0.71	22.2	7/8
P08-10FJ45	1/2	7/8 - 14	49.3	1.94	87.9	3.46	21.3	0.84	25.4	1
P12-12FJ45	3/4	1 1/16 - 12	65.3	2.57	108.2	4.26	28.4	1.12	31.8	1 1/4
P16-16FJ45	1	1 5/16 - 12	73.2	2.88	125.7	4.95	29.2	1.15	38.1	1 1/2

FJ90M

JIC 37° FEMALE SWIVEL - 90° ELBOW MEDIUM DROP

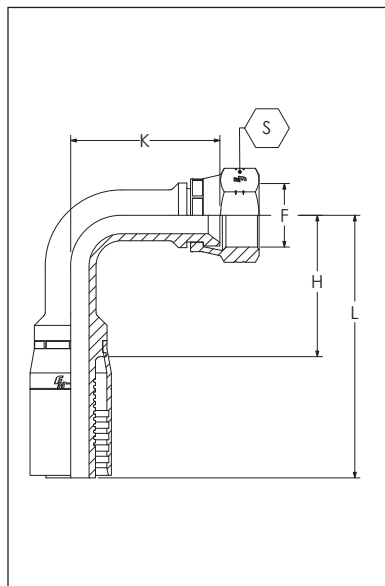

PART NUMBER	Hose Bore	F	H		L		K		S	
	INCH		[mm]	[in]	[mm]	[in]	[mm]	[in]	[mm]	[in]
P02-03FJ90M	1/8	3/8 - 24	23.9	0.94	37.7	1.48	19.1	0.75	11.1	7/16
P02-04FJ90M	1/8	7/16 - 20	28.7	1.13	42.4	1.67	22.2	0.88	14.3	9/16
P03-04FJ90M	1/8	7/16 - 20	31.8	1.25	52.3	2.06	22.2	0.88	14.3	9/16
P04-04FJ90M	1/4	7/16 - 20	31.8	1.25	58.6	2.31	22.2	0.88	14.3	9/16
P04-05FJ90M	1/4	1/2 - 20	49.3	1.94	60.2	2.37	25.4	1.00	15.9	5/8
P04-06FJ90M	1/4	9/16 - 18	35.1	1.38	61.8	2.43	28.6	1.13	17.5	11/16
P05-05FJ90M	1/3	1/2 - 20	31.8	1.25	60.2	2.37	25.4	1.00	15.9	5/8
P05-06FJ90M	1/3	9/16 - 18	49.3	1.94	61.7	2.43	28.6	1.13	17.5	11/16
P06-04FJ90M	3/8	7/16 - 20	31.8	1.25	63.5	2.50	22.2	0.88	14.3	9/16
P06-06FJ90M	3/8	9/16 - 18	35.1	1.38	66.5	2.62	28.6	1.13	17.5	11/16
P06-08FJ90M	3/8	3/4 - 16	38.1	1.50	69.9	2.75	34.9	1.38	22.2	7/8
P08-08FJ90M	1/2	3/4 - 16	36.6	1.44	74.5	2.93	34.9	1.38	22.2	7/8
P08-10FJ90M	1/2	7/8 - 14	39.6	1.56	77.6	3.06	41.3	1.63	25.4	1
P12-12FJ90M	3/4	1 1/16 - 12	55.6	2.19	98.3	3.87	58.7	2.31	31.8	1 1/4
P16-16FJ90M	1	1 5/16 - 12	66.8	2.63	118.9	4.68	63.5	2.50	38.1	1 1/2

Reference Hose Section for Coupling Compatibility

COUPLINGS

FJ90L

JIC 37° FEMALE SWIVEL - 90° ELBOW LONG DROP

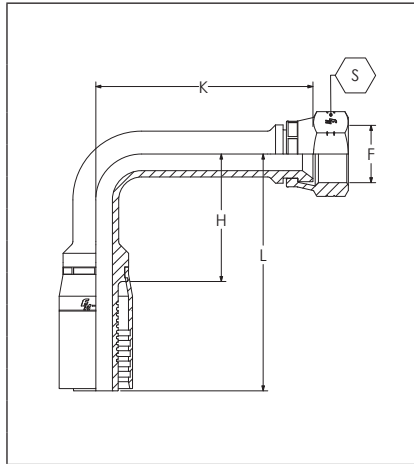

PART NUMBER	Hose Bore	F	H		L		K		S	
	INCH		[mm]	[in]	[mm]	[in]	[mm]	[in]	[mm]	[in]
P03-04FJ90L	1/5	7/16 - 20	31.8	1.25	52.3	2.06	45.7	1.80	14.3	9/16
P04-04FJ90L	1/4	7/16 - 20	31.8	1.25	58.6	2.31	45.7	1.80	14.3	9/16
P04-05FJ90L	1/4	1/2 - 20	49.3	1.94	60.2	2.37	45.0	1.77	15.9	5/8
P04-06FJ90L	1/4	9/16 - 18	35.1	1.38	62.4	2.46	55.4	2.18	17.5	11/16
P05-06FJ90L	1/3	9/16 - 18	49.3	1.94	61.8	2.43	55.4	2.18	17.5	11/16
P06-06FJ90L	3/8	9/16 - 18	35.1	1.38	66.5	2.62	55.4	2.18	17.5	11/16
P06-08FJ90L	3/8	3/4 - 16	38.1	1.50	69.9	2.75	61.7	2.43	22.2	7/8
P08-08FJ90L	1/2	3/4 - 16	36.6	1.44	74.5	2.93	61.7	2.43	22.2	7/8
P12-10FJ90L	3/4	7/8 - 14	39.6	1.56	77.6	3.06	65.3	2.57	25.4	1
P12-12FJ90L	3/4	1 1/16 - 12	55.6	2.19	98.3	3.87	94.7	3.73	31.8	1 1/4
P16-16FJ90L	1	1 5/16 - 12	66.8	2.63	119.0	4.69	110.0	4.33	38.1	1 1/2

MF

ORFS MALE

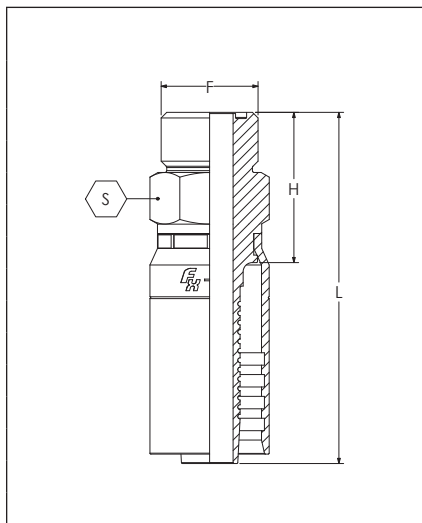

PART NUMBER	Hose Bore	F	H		L		S	
	INCH		[mm]	[in]	[mm]	[in]	[mm]	[in]
P03-04MF	1/5	7/16 - 20	35.1	1.38	54.6	2.15	14.3	9/16
P03-05MF	1/5	1/2 - 20	35.1	1.38	54.6	2.15	14.3	9/16
P04-04MF	1/4	7/16 - 20	36.6	1.44	64.2	2.53	15.9	5/8
P04-05MF	1/4	1/2 - 20	36.6	1.44	64.2	2.53	15.9	5/8
P04-06MF	1/4	5/8 - 18	36.6	1.44	64.2	2.53	15.9	5/8
P05-05MF	1/3	1/2 - 20	35.1	1.38	64.2	2.53	15.9	5/8
P05-06MF	1/3	5/8 - 18	35.1	1.38	64.2	2.53	15.9	5/8
P06-06MF	3/8	5/8 - 18	39.6	1.56	71.3	2.81	19.1	3/4
P06-08MF	3/8	3/4 - 16	39.6	1.56	71.3	2.81	19.1	3/4
P08-08MF	1/2	3/4 - 16	41.4	1.63	80.0	3.15	22.2	7/8
P08-10MF	1/2	7/8 - 14	41.4	1.63	80.0	3.15	22.2	7/8
P12-12MF	3/4	1 1/16 - 14	44.5	1.75	87.2	3.43	31.8	1 1/4
P16-16MF	1	1 3/8 - 12	55.6	2.19	107.9	4.25	41.3	1 5/8

FF

ORFS FEMALE SWIVEL

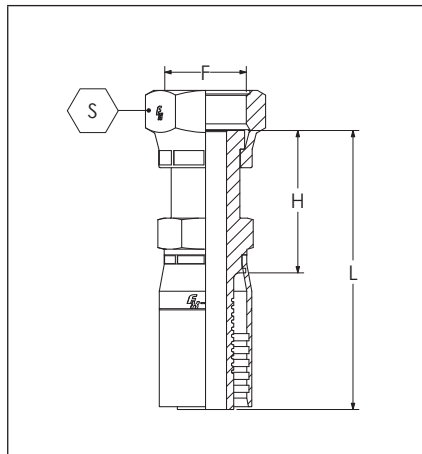

PART NUMBER	Hose Bore	F	H		L		S		S1	
	INCH		[mm]	[in]	[mm]	[in]	[mm]	[in]	[mm]	[in]
P02-04FF	1/8	9/16 - 18	31.0	1.22	45.2	1.78	17.5	11/16	15.9	5/8
P04-04FF	1/4	9/16 - 18	38.6	1.52	66.0	2.60	17.5	11/16	15.9	5/8
P04-06FF	1/4	1 1/16 - 16	36.1	1.42	63.6	2.50	22.2	7/8	15.9	5/8
P05-04FF	1/3	1 1/16 - 16	37.5	1.48	66.0	2.60	17.5	11/16	15.9	5/8
P05-06FF	1/3	1 1/16 - 16	39.2	1.55	67.8	2.67	20.6	13/16	15.9	5/8
P06-06FF	3/8	1 1/16 - 16	36.6	1.44	68.3	2.69	22.2	7/8	19.1	3/4
P06-08FF	3/8	1 3/16 - 16	45.4	1.79	77.2	3.04	23.8	15/16	19.1	3/4
P08-08FF	1/2	1 3/16 - 16	39.8	1.57	77.7	3.06	27.0	1 1/16	23.8	15/16
P08-10FF	1/2	1 - 14	46.5	1.83	84.5	3.33	28.6	1 1/8	22.2	7/8
P12-12FF	3/4	1 3/16 - 12	49.7	1.96	92.5	3.64	34.9	1 3/8	28.6	1 1/8
P16-16FF	1	1 7/16 - 12	55.1	2.17	110.7	4.36	41.3	1 5/8	41.3	1 5/8

Reference Hose Section for Coupling Compatibility

COUPLINGS

FF90M ORFS FEMALE SWIVEL - 90° ELBOW MEDIUM DROP

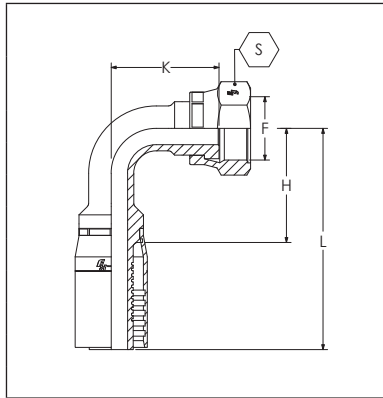

PART NUMBER	Hose Bore	F	H		L		K		S	
	INCH		[mm]	[in]	[mm]	[in]	[mm]	[in]	[mm]	[in]
P02-04FF90M	1/8	7/16 - 20	28.7	1.13	42.6	1.68	19.8	0.78	17.5	11/16
P04-04FF90M	1/4	7/16 - 20	31.8	1.25	58.8	2.31	19.8	0.78	17.5	11/16
P05-04FF90M	1/3	9/16 - 18	30.2	1.19	58.8	2.31	19.8	0.78	17.5	11/16
P05-06FF90M	1/3	9/16 - 18	49.3	1.94	63.3	2.49	22.9	0.90	20.6	13/16
P06-06FF90M	3/8	9/16 - 18	36.6	1.44	68.1	2.68	22.9	0.90	20.6	13/16
P08-08FF90M	1/2	3/4 - 16	38.1	1.50	75.7	2.98	29.2	1.15	23.8	15/16
P12-12FF90M	3/4	1 1/16 - 12	50.8	2.00	94.2	3.71	47.8	1.88	34.9	1 3/8

MOB O-RING BOSS MALE

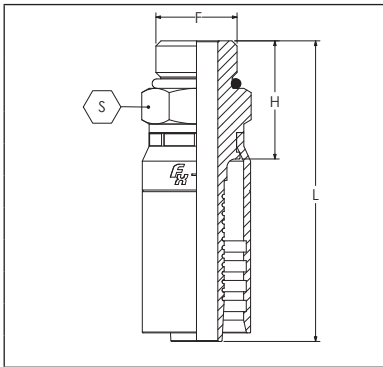

PART NUMBER	Hose Bore	F	H		L		S	
	INCH		[mm]	[in]	[mm]	[in]	[mm]	[in]
P03-04MOB	1/8	7/16 - 20	26.9	1.06	48.0	1.89	14.3	9/16
P04-04MOB	1/4	7/16 - 20	26.2	1.03	53.5	2.11	15.9	5/8
P04-05MOB	1/4	1/2 - 20	26.2	1.03	53.5	2.11	15.9	5/8
P04-06MOB	1/4	9/16 - 18	26.9	1.06	54.3	2.14	14.5	11/16
P05-05MOB	1/3	1/2 - 20	22.4	0.88	54.5	2.11	14.5	11/16
P06-06MOB	3/8	9/16 - 18	29.5	1.16	61.4	2.42	19.1	3/4
P06-08MOB	3/8	3/4 - 16	30.2	1.19	62.6	2.47	22.2	7/8
P08-08MOB	1/2	3/4 - 16	27.7	1.09	68.9	2.71	23.8	15/16

Reference Hose Section for Coupling Compatibility

COUPLINGS

MP NPT MALE

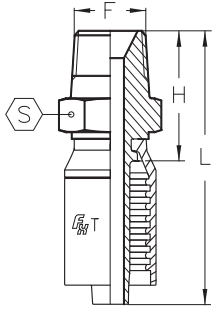

PART NUMBER	Hose Bore	F	H		L		S	
	INCH		[mm]	[in]	[mm]	[in]	[mm]	[in]
T03-02MP	3/16	1/8 - 27	20.6	0.81	45.6	1.79	12	1/2
T03-04MP	3/16	1/4 - 18	26.5	1.04	51.5	2.03	14	9/16
T04-02MP	1/4	1/8 - 27	21.1	0.83	49.1	1.93	12	1/2
T04-04MP	1/4	1/4 - 18	27.0	1.06	55.0	2.16	14	9/16
T04-06MP	1/4	3/8 - 18	28.6	1.12	56.6	2.23	19	3/4
T04-08MP	1/4	1/2 - 14	34.0	1.34	62.0	2.44	22	7/8
T05-04MP	5/16	1/4 - 18	27.0	1.06	55.0	2.16	14	9/16
T05-06MP	5/16	3/8 - 18	28.6	1.12	56.6	2.23	19	3/4
T06-04MP	3/8	1/4 - 18	27.5	1.08	58.0	2.28	16	5/8
T06-06MP	3/8	3/8 - 18	28.6	1.12	59.1	2.33	19	3/4
T06-08MP	3/8	1/2 - 14	34.0	1.34	64.5	2.54	22	7/8
T08-04MP	1/2	1/4 - 18	30.5	1.20	63.2	2.49	22	7/8
T08-06MP	1/2	3/8 - 18	30.6	1.20	63.6	2.50	22	7/8
T08-08MP	1/2	1/2 - 14	35.0	1.38	68.0	2.68	22	7/8
T08-12MP	1/2	3/4 - 14	36.9	1.45	69.9	2.75	27	1 1/16
T10-08MP	5/8	1/2 - 14	36.2	1.42	72.0	2.83	25	1
T10-12MP	5/8	3/4 - 14	37.1	1.46	72.9	2.87	27	1 1/16
T12-08MP	3/4	1/2 - 14	37.5	1.48	78.0	3.07	27	1 1/16
T12-12MP	3/4	3/4 - 14	37.9	1.49	78.4	3.09	27	1 1/16
T12-16MP	3/4	1 - 11 1/2	45.5	1.79	86.0	3.38	35	1 7/16
T16-12MP	1	3/4 - 14	40.4	1.59	91.4	3.60	32	1 1/4
T16-16MP	1	1 - 11 1/2	47.0	1.85	98.0	3.86	35	1 7/16

MPX NPT MALE SWIVEL

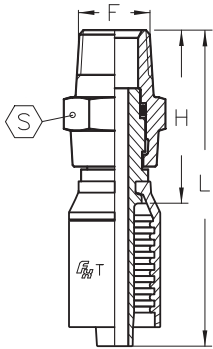

PART NUMBER	Hose Bore	F	H		L		S	
	INCH		[mm]	[in]	[mm]	[in]	[mm]	[in]
T04-04MPX	1/4	1/4 - 18	41	1.61	69	2.72	17	1 1/16
T04-06MPX	1/4	3/8 - 18	46	1.81	74	2.91	22	7/8
T06-04MPX	3/8	1/4 - 18	41	1.61	72	2.83	17	1 1/16
T06-06MPX	3/8	3/8 - 18	45	1.77	75	2.95	22	7/8
T06-08MPX	3/8	1/2 - 14	57	2.24	88	3.46	27	1 1/16
T08-06MPX	1/2	3/8 - 18	46	1.81	79	3.11	22	7/8
T08-08MPX	1/2	1/2 - 14	56	2.20	89	3.50	27	1 1/16
T12-08MPX	3/4	1/2 - 14	57	2.24	98	3.86	27	1 1/16
T12-12MPX	3/4	3/4 - 14	61	2.40	101	3.98	34	1 3/8
T16-16MPX	1	1 - 11 1/2	65	2.56	116	4.57	38	1 1/2

Reference Hose Section for Coupling Compatibility

COUPLINGS

FP NPT FEMALE RIGID (DRY SEAL)

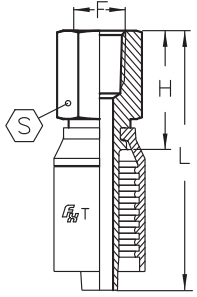
	PART NUMBER	Hose Bore	F	H		L		S	
		INCH		[mm]	[in]	[mm]	[in]	[mm]	[in]
				T04-02FP	1/4	1/8 - 27	21.5	0.85	49.5
T04-04FP	1/4	1/4 - 18	27.1	1.07	55.1	2.17	19	3/4	
T04-06FP	1/4	3/8 - 18	28.4	1.12	56.4	2.22	22	7/8	
T06-04FP	3/8	1/4 - 18	27.1	1.07	57.6	2.27	19	3/4	
T06-06FP	3/8	3/8 - 18	28.4	1.12	58.9	2.32	22	7/8	
T06-08FP	3/8	1/2 - 14	34.5	1.36	65.0	2.56	29	1 3/16	
T08-08FP	1/2	1/2 - 14	35.5	1.40	68.5	2.70	29	1 3/16	
T12-12FP	3/4	3/4 - 14	38.0	1.50	78.5	3.09	32	1 1/4	

FPX NPSM FEMALE SWIVEL (60° CONE SEAT)

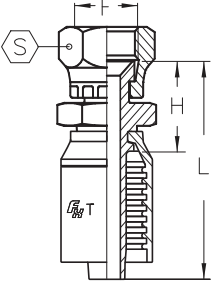
	PART NUMBER	Hose Bore	F	H		L		S	
		INCH		[mm]	[in]	[mm]	[in]	[mm]	[in]
				T04-04FPX	1/4	1/4 - 18	19	0.75	47
T06-06FPX	3/8	3/8 - 18	21	0.83	51	2.00	22	7/8	
T08-08FPX	1/2	1/2 - 14	23	0.90	56	2.20	25	1	
T12-12FPX	3/4	3/4 - 14	27	1.06	67	2.64	32	1 1/4	
T16-16FPX	1	1 - 11 1/2	30	1.18	81	3.19	38	1 1/2	

MJ JIC 37° MALE

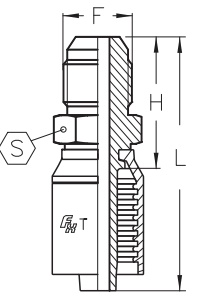
	PART NUMBER	Hose Bore	F	H		L		S	
		INCH		[mm]	[in]	[mm]	[in]	[mm]	[in]
				T03-04MJ	3/16	7/16 - 20	25.0	0.98	50.0
T04-04MJ	1/4	7/16 - 20	25.5	1.00	53.5	2.11	12	1/2	
T04-05MJ	1/4	1/2 - 20	25.5	1.00	53.5	2.11	14	9/16	
T04-06MJ	1/4	9/16 - 18	26.6	1.05	54.6	2.15	15	5/8	
T05-05MJ	5/16	1/2 - 20	25.5	1.00	53.5	2.11	14	9/16	
T05-06MJ	5/16	9/16 - 18	26.6	1.05	54.6	2.15	15	5/8	
T06-06MJ	3/8	9/16 - 18	26.6	1.05	57.1	2.25	15	5/8	
T06-08MJ	3/8	3/4 - 16	29.7	1.17	60.2	2.37	19	3/4	
T08-08MJ	1/2	3/4 - 16	30.7	1.21	63.7	2.51	19	3/4	
T08-10MJ	1/2	7/8 - 14	35.3	1.39	68.3	2.69	24	1	
T08-12MJ	1/2	1 1/16 - 12	38.9	1.53	71.9	2.83	27	1 1/16	
T12-12MJ	3/4	1 1/16 - 12	39.9	1.57	80.4	3.16	27	1 1/16	
T16-16MJ	1	1 5/16 - 12	43.6	1.72	94.6	3.72	34	1 3/8	

Reference Hose Section for Coupling Compatibility

COUPLINGS

FJ JIC 37° FEMALE SWIVEL

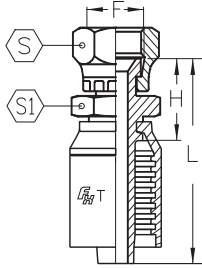

PART NUMBER	Hose Bore INCH	F	H		L		S		S1	
			[mm]	[in]	[mm]	[in]	[mm]	[in]	[mm]	[in]
T03-04FJ	3/16	7/16 - 20	19.0	0.75	44.0	1.73	14	9/16	12	1/2
T04-04FJ	1/4	7/16 - 20	20.5	0.81	48.5	1.91	14	9/16	14	9/16
T04-05FJ	1/4	1/2 - 20	21.0	0.83	49.0	1.93	17	11/16	14	9/16
T04-06FJ	1/4	9/16 - 18	22.0	0.87	50.0	1.97	19	3/4	14	9/16
T05-05FJ	5/16	1/2 - 20	21.0	0.83	49.0	1.93	17	11/16	14	9/16
T05-06FJ	5/16	9/16 - 18	22.5	0.88	50.5	1.99	19	3/4	16	5/8
T06-04FJ	3/8	7/16 - 20	21.0	0.83	51.5	2.03	14	9/16	16	5/8
T06-05FJ	3/8	1/2 - 20	21.5	0.85	52.0	2.05	17	11/16	16	5/8
T06-06FJ	3/8	9/16 - 18	22.5	0.88	53.0	2.09	19	3/4	16	5/8
T06-08FJ	3/8	3/4 - 16	24.5	0.96	55.0	2.16	22	7/8	19	3/4
T06-10FJ	3/8	7/8 - 14	36.5	1.44	57.0	2.24	27	1 1/16	22	7/8
T08-06FJ	1/2	9/16 - 18	24.5	0.96	57.5	2.26	19	3/4	19	3/4
T08-08FJ	1/2	3/4 - 16	25.5	1.00	58.5	2.30	22	7/8	19	3/4
T08-10FJ	1/2	7/8 - 14	27.5	1.08	60.5	2.38	27	1 1/16	22	7/8
T08-12FJ	1/2	1 1/16 - 12	30.3	1.19	63.3	2.49	32	1 1/4	25	1
T10-08FJ	5/8	3/4 - 16	26.7	1.05	62.5	2.46	22	7/8	22	7/8
T10-10FJ	5/8	7/8 - 14	27.7	1.09	63.5	2.50	27	1 1/16	22	7/8
T10-12FJ	1 1/16	1 1/16 - 12	30.5	1.20	66.3	2.61	32	1 1/4	25	1
T12-10FJ	3/4	7/8 - 14	30.0	1.18	70.5	2.77	27	1 1/16	27	1 1/16
T12-12FJ	3/4	1 1/16 - 12	31.8	1.25	72.3	2.85	32	1 1/4	27	1 1/16
T12-14FJ	3/4	1 3/16 - 12	34.5	1.36	75.0	2.95	36	1 7/16	30	1 3/16
T12-16FJ	3/4	1 5/16 - 12	35.5	1.40	76.0	2.99	38	1 1/2	32	1 1/4
T16-12FJ	1	1 1/16 - 12	34.3	1.35	85.3	3.36	32	1 1/4	32	1 1/4
T16-16FJ	1	1 5/16 - 12	37.0	1.46	88.0	3.46	38	1 1/2	32	1 1/4

FJ45 JIC 37° FEMALE SWIVEL - 45° ELBOW

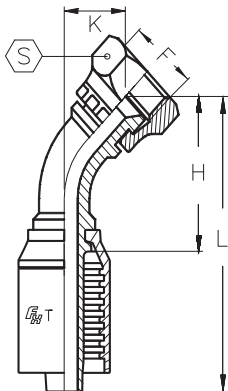

PART NUMBER	Hose Bore INCH	F	H		L		K		S	
			[mm]	[in]	[mm]	[in]	[mm]	[in]	[mm]	[in]
T03-04FJ45	3/16	7/16 - 20	29.0	1.14	54.0	2.12	10.0	0.39	14	9/16
T04-04FJ45	1/4	7/16 - 20	31.0	1.22	59.0	2.32	10.0	0.39	14	9/16
T04-05FJ45	1/4	1/2 - 20	32.0	1.26	60.0	2.36	11.0	0.43	17	11/16
T04-06FJ45	1/4	9/16 - 18	33.0	1.30	61.0	2.40	12.0	0.47	19	3/4
T05-05FJ45	5/16	1/2 - 20	33.0	1.30	61.0	2.40	11.0	0.43	17	11/16
T05-06FJ45	5/16	9/16 - 18	34.0	1.34	62.0	2.44	12.0	0.47	19	3/4
T06-06FJ45	3/8	9/16 - 18	35.5	1.40	66.0	2.60	12.0	0.47	19	3/4
T06-08FJ45	3/8	3/4 - 16	37.5	1.48	68.0	2.68	14.0	0.55	22	7/8
T08-08FJ45	1/2	3/4 - 16	41.0	1.61	74.0	2.91	14.5	0.57	22	7/8
T08-10FJ45	1/2	7/8 - 14	43.0	1.69	76.0	2.99	16.0	0.63	27	1 1/16
T08-12FJ45	1/2	1 1/16 - 12	45.5	1.79	78.5	3.09	19.0	0.75	32	1 1/4
T10-10FJ45	5/8	7/8 - 14	47.0	1.85	83.0	3.27	16.0	0.63	27	1 1/16
T10-12FJ45	5/8	1 1/16 - 12	50.0	1.97	86.0	3.38	19.0	0.75	32	1 1/4
T12-12FJ45	3/4	1 1/16 - 12	57.0	2.24	97.0	3.82	20.0	0.79	32	1 1/4
T12-14FJ45	3/4	1 3/16 - 12	59.0	2.32	100.0	3.94	22.0	0.87	36	1 7/16
T12-16FJ45	3/4	1 5/16 - 12	61.0	2.40	101.0	3.98	24.0	0.94	38	1 1/2
T16-16FJ45	1	1 5/16 - 12	72.0	2.83	123.0	4.84	24.0	0.94	38	1 1/2

Reference Hose Section for Coupling Compatibility

COUPLINGS

FJ90B BSP FEMALE 60° CONE - 90° COMPACT ELBOW

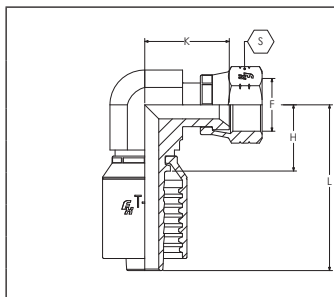

PART NUMBER	Hose Bore	F	H		L		K		S	
	INCH		[mm]	[in]	[mm]	[in]	[mm]	[in]	[mm]	[in]
T04-04FJ90B	1/4	1/4 - 19	18	0.71	46	1.81	23	0.91	19	3/4
T06-06FJ90B	3/8	3/8 - 19	21	0.83	52	2.05	26	1.02	22	7/8
T08-08FJ90B	1/2	1/2 - 14	24	0.94	57	2.24	28	1.10	27	1 1/16

FJ90S JIC 37° FEMALE SWIVEL - 90° ELBOW SHORT DROP

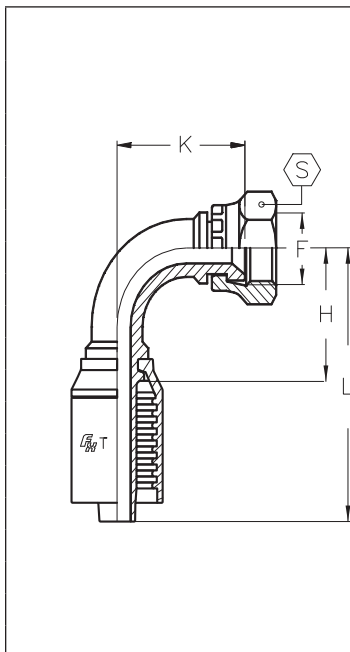

PART NUMBER	Hose Bore	F	H		L		K		S	
	INCH		[mm]	[in]	[mm]	[in]	[mm]	[in]	[mm]	[in]
T03-04FJ90S	3/16	7/16 - 20	21.0	0.83	46.0	1.81	18	0.71	14	9/16
T04-04FJ90S	1/4	7/16 - 20	25.5	1.00	53.5	2.11	20	0.79	14	9/16
T04-05FJ90S	1/4	1/2 - 20	25.5	1.00	53.5	2.11	21	0.83	17	11/16
T04-06FJ90S	1/4	9/16 - 18	25.5	1.00	53.5	2.11	23	0.90	19	3/4
T05-05FJ90S	5/16	1/2 - 20	28.0	1.10	56.0	2.20	22	0.87	17	11/16
T05-06FJ90S	5/16	9/16 - 18	28.0	1.10	56.0	2.20	24	0.94	19	3/4
T06-06FJ90S	3/8	9/16 - 18	30.0	1.18	60.5	2.38	23	0.90	19	3/4
T06-08FJ90S	3/8	3/4 - 16	31.0	1.22	61.5	2.42	29	1.14	22	7/8
T08-08FJ90S	1/2	3/4 - 16	37.0	1.46	70.0	2.75	29	1.14	22	7/8
T08-10FJ90S	1/2	7/8 - 14	38.0	1.50	71.0	2.79	33	1.30	27	1 1/16
T08-12FJ90S	1/2	1 1/16 - 12	40.0	1.57	73.0	2.87	40	1.57	32	1 1/4
T10-10FJ90S	5/8	7/8 - 14	43.0	1.69	79.0	3.11	32	1.26	27	1 1/16
T10-12FJ90S	5/8	1 1/16 - 12	45.0	1.77	81.0	3.19	40	1.57	32	1 1/4
T12-12FJ90S	3/4	1 1/16 - 12	55.0	2.16	95.0	3.74	43	1.69	32	1 1/4
T12-14FJ90S	3/4	1 3/16 - 12	55.0	2.16	95.0	3.74	47	1.85	36	1 7/16
T12-16FJ90S	3/4	1 5/16 - 12	55.0	2.16	95.0	3.74	49	1.93	38	1 1/2
T16-16FJ90S	1	1 5/16 - 12	71.0	2.79	122.0	4.80	56	2.20	38	1 1/2

Reference Hose Section for Coupling Compatibility

COUPLINGS

FJ90M

JIC 37° FEMALE SWIVEL - 90° ELBOW MEDIUM DROP

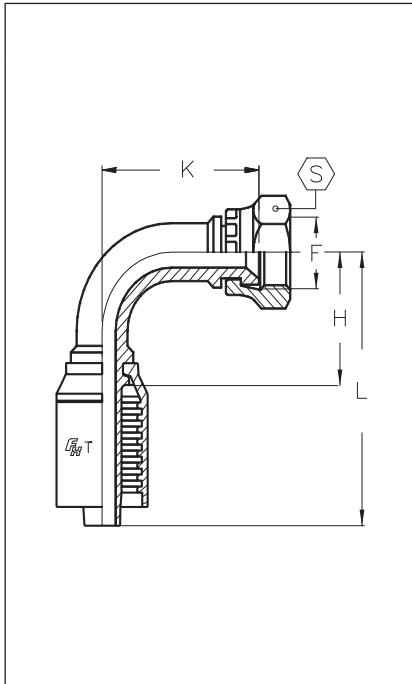

PART NUMBER	Hose Bore	F	H		L		K		S	
	INCH		[mm]	[in]	[mm]	[in]	[mm]	[in]	[mm]	[in]
T03-04FJ90M	3/16	7/16 - 20	21.0	0.83	46.0	1.81	21	0.83	14	9/16
T04-04FJ90M	1/4	7/16 - 20	25.5	1.00	53.5	2.11	26	1.02	14	9/16
T04-05FJ90M	1/4	1/2 - 20	25.5	1.00	53.5	2.11	26	1.02	17	11/16
T04-06FJ90M	1/4	9/16 - 18	25.5	1.00	53.5	2.11	27	1.06	19	3/4
T05-05FJ90M	5/16	1/2 - 20	28.0	1.10	56.0	2.20	29	1.14	17	11/16
T05-06FJ90M	5/16	9/16 - 18	28.0	1.10	56.0	2.20	29	1.14	19	3/4
T06-06FJ90M	3/8	9/16 - 18	31.0	1.22	61.5	2.42	33	1.30	19	3/4
T06-08FJ90M	3/8	3/4 - 16	31.0	1.22	61.5	2.42	33	1.30	22	7/8
T08-08FJ90M	1/2	3/4 - 16	37.0	1.46	70.0	2.75	39	1.53	22	7/8
T08-10FJ90M	1/2	7/8 - 14	37.0	1.46	70.0	2.75	40	1.57	27	1 1/16
T10-10FJ90M	5/8	7/8 - 14	45.0	1.77	81.0	3.19	45	1.77	27	1 1/16
T10-12FJ90M	5/8	1 1/16 - 12	45.0	1.77	81.0	3.19	47	1.85	32	1 1/4
T12-10FJ90M	3/4	7/8 - 14	55.0	2.16	95.0	3.74	54	2.12	27	1 1/16
T12-12FJ90M	3/4	1 1/16 - 12	55.0	2.16	95.0	3.74	53	2.09	32	1 1/4
T12-14FJ90M	3/4	1 3/16 - 12	55.0	2.16	95.0	3.74	54	2.12	36	17/16
T12-16FJ90M	3/4	1 5/16 - 12	55.0	2.16	95.0	3.74	56	2.20	38	1 1/2
T16-12FJ90M	1	1 1/16 - 12	71.0	2.79	122.0	4.80	71	2.79	32	1 1/4
T16-16FJ90M	1	1 5/16 - 12	71.0	2.79	122.0	4.80	70	2.75	38	1 1/2

FJ90L

JIC 37° FEMALE SWIVEL - 90° ELBOW LONG DROP

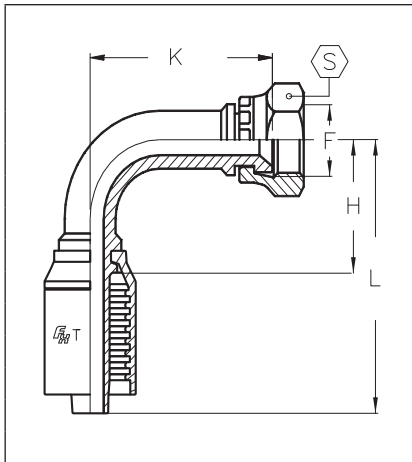

PART NUMBER	Hose Bore	F	H		L		K		S	
	INCH		[mm]	[in]	[mm]	[in]	[mm]	[in]	[mm]	[in]
T04-04FJ90L	1/4	7/16 - 20	25.5	1.00	53.5	2.11	46	1.81	14	9/16
T04-05FJ90L	1/4	1/2 - 20	25.5	1.00	53.5	2.11	46	1.81	17	11/16
T04-06FJ90L	1/4	9/16 - 18	25.5	1.00	53.5	2.11	54	2.12	19	3/4
T06-06FJ90L	3/8	9/16 - 18	31.0	1.22	61.5	2.42	54	2.12	19	3/4
T06-08FJ90L	3/8	3/4 - 16	31.0	1.22	61.5	2.42	64	2.52	22	7/8
T08-08FJ90L	1/2	3/4 - 16	38.0	1.50	71.0	2.79	64	2.52	22	7/8
T08-10FJ90L	1/2	7/8 - 14	38.0	1.50	71.0	2.79	70	2.75	27	1 1/16
T10-10FJ90L	5/8	7/8 - 14	45.0	1.77	81.0	3.19	70	2.75	27	1 1/16
T10-12FJ90L	5/8	1 1/16 - 12	45.0	1.77	81.0	3.19	96	3.78	32	1 1/4
T12-12FJ90L	3/4	1 1/16 - 12	55.0	2.16	95.0	3.74	96	3.78	32	1 1/4
T16-16FJ90L	1	1 5/16 - 12	71.0	2.79	122	4.80	114	4.49	38	1 1/2

Reference Hose Section for Coupling Compatibility

COUPLINGS

MF ORFS MALE

PART NUMBER	Hose Bore	F	H		L		S	
	INCH		[mm]	[in]	[mm]	[in]	[mm]	[in]
T04-04MF	1/4	9/16 - 18	23.5	0.92	51.5	2.02	17	11/16
T04-06MF	1/4	11/16 - 16	25.5	1.00	53.5	2.10	19	3/4
T06-06MF	3/8	11/16 - 16	25.5	1.00	56.0	2.20	19	3/4
T06-08MF	3/8	13/16 - 16	28.5	1.12	59.0	2.32	22	7/8
T06-10MF	3/8	1 - 14	33.0	1.29	63.5	2.50	27	1 1/16
T08-08MF	1/2	13/16 - 16	29.5	1.16	62.5	2.46	22	7/8
T08-10MF	1/2	1 - 14	34.0	1.33	67.0	2.63	27	1 1/16
T08-12MF	1/2	1 3/16 - 12	37.0	1.45	70.0	2.75	32	1 1/4
T10-10MF	5/8	1 - 14	34.0	1.33	70.0	2.75	27	1 1/16
T10-12MF	5/8	1 3/16 - 12	37.0	1.45	73.0	2.87	32	1 1/4
T12-12MF	3/4	1 3/16 - 12	38.0	1.49	78.5	3.09	32	1 1/4
T12-16MF	3/4	1 7/16 - 12	42.5	1.67	83.0	3.26	41	1 5/8
T16-16MF	1	1 7/16 - 12	44.0	1.73	95.0	3.74	41	1 5/8

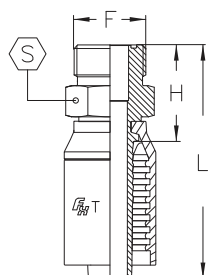

FF ORFS FEMALE SWIVEL

PART NUMBER	Hose Bore	F	H		L		S		S1	
	INCH		[mm]	[in]	[mm]	[in]	[mm]	[in]	[mm]	[in]
T04-04FF	1/4	9/16 - 18	26.5	1.04	54.5	2.14	17	11/16	14	9/16
T04-06FF	1/4	11/16 - 16	28.5	1.12	56.5	2.22	22	7/8	16	5/8
T05-06FF	5/16	11/16 - 16	28.5	1.12	56.5	2.22	22	7/8	16	5/8
T06-04FF	3/8	9/16 - 18	26.5	1.04	57.0	2.24	17	11/16	16	5/8
T06-06FF	3/8	11/16 - 16	28.5	1.12	59.0	2.32	22	7/8	16	5/8
T06-08FF	3/8	13/16 - 16	32.5	1.27	63.0	2.48	24	1	19	3/4
T08-06FF	1/2	11/16 - 16	30.5	1.20	63.5	2.50	22	7/8	19	3/4
T08-08FF	1/2	13/16 - 16	33.5	1.31	66.5	2.61	24	1	19	3/4
T08-10FF	1/2	1 - 14	39.5	1.55	72.5	2.85	30	1 3/16	24	1
T08-12FF	1/2	1 3/16 - 12	43.5	1.71	76.5	3.01	36	1 7/16	27	1 1/16
T10-10FF	5/8	1 - 14	39.5	1.55	75.5	2.97	30	1 3/16	24	1
T10-12FF	5/8	1 3/16 - 12	43.5	1.71	79.5	3.12	36	1 7/16	27	1 1/16
T12-10FF	3/4	1 - 14	41.5	1.63	82.0	3.22	30	1 3/16	27	1 1/16
T12-12FF	3/4	1 3/16 - 12	44.5	1.75	85.0	3.34	36	1 7/16	27	1 1/16
T12-16FF	3/4	1 7/16 - 12	47.5	1.87	88.0	3.46	41	1 5/8	36	1 7/16
T16-12FF	1	1 3/16 - 12	47.0	1.85	98.0	3.85	36	1 7/16	32	1 1/4
T16-16FF	1	1 7/16 - 12	49.0	1.92	100.0	3.93	41	1 5/8	36	1 7/16

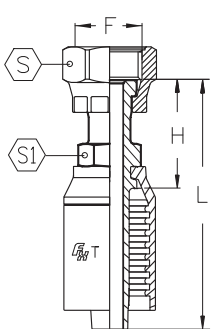

Reference Hose Section for Coupling Compatibility

COUPLINGS

FF45

ORFS FEMALE SWIVEL - 45° ELBOW

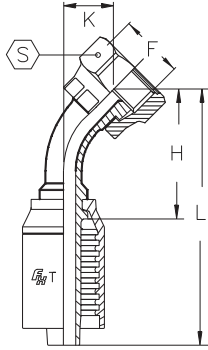

PART NUMBER	Hose Bore	F	H		L		K		S	
	INCH		[mm]	[in]	[mm]	[in]	[mm]	[in]	[mm]	[in]
T04-04FF45	1/4	9/16 - 18	32.5	1.27	60.5	2.38	10.5	0.41	17	11/16
T04-06FF45	1/4	11/16 - 16	34.5	1.35	62.5	2.46	12.5	0.49	22	7/8
T05-06FF45	5/16	11/16 - 16	35.0	1.37	63.0	2.48	12.5	0.49	22	7/8
T06-06FF45	3/8	11/16 - 16	36.0	1.41	66.5	2.61	12.5	0.49	22	7/8
T06-08FF45	3/8	13/16 - 16	38.5	1.51	69.0	2.71	15.0	0.59	24	1
T08-06FF45	1/2	11/16 - 16	46.5	1.83	79.5	3.12	19.5	0.76	22	7/8
T08-08FF45	1/2	13/16 - 16	42.5	1.67	75.5	2.97	15.5	0.61	24	1
T08-10FF45	1/2	1 - 14	45.0	1.77	78.0	3.07	17.5	0.68	30	13/16
T08-12FF45	1/2	13/16 - 12	47.0	1.85	80.0	3.14	20.5	0.80	36	17/16
T10-10FF45	5/8	1 - 14	49.0	1.92	85.0	3.34	18.0	0.70	30	13/16
T10-12FF45	5/8	13/16 - 12	51.5	2.02	87.5	3.44	20.5	0.80	36	17/16
T12-10FF45	3/4	1 - 14	64.0	2.51	104.0	4.09	25.5	1.00	30	13/16
T12-12FF45	3/4	13/16 - 12	58.0	2.28	99.0	3.89	21.0	0.82	36	17/16
T12-16FF45	3/4	17/16 - 12	60.5	2.38	101.0	3.97	23.5	0.92	41	15/8
T16-16FF45	1	17/16 - 12	73.0	2.87	124.0	4.88	24.0	0.94	41	15/8

FF90S

ORFS FEMALE SWIVEL - 90° ELBOW SHORT DROP

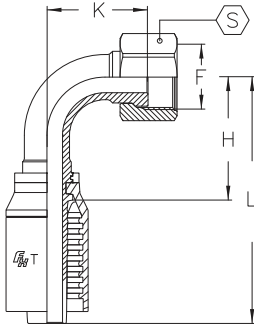

PART NUMBER	Hose Bore	F	H		L		K		S	
	INCH		[mm]	[in]	[mm]	[in]	[mm]	[in]	[mm]	[in]
T04-04FF90S	1/4	9/16 - 18	27.0	1.06	55.0	2.17	21.0	0.82	17	11/16
T04-06FF90S	1/4	11/16 - 16	27.0	1.06	55.0	2.17	24.0	0.94	22	7/8
T05-06FF90S	5/16	11/16 - 16	29.0	1.14	57.0	2.24	25.0	0.98	22	7/8
T06-04FF90S	3/8	9/16 - 18	30.0	1.18	60.5	2.38	22.0	0.87	17	11/16
T06-06FF90S	3/8	11/16 - 16	31.5	1.24	62.0	2.44	24.5	0.96	22	7/8
T06-08FF90S	3/8	13/16 - 16	31.0	1.22	61.0	2.40	30.0	1.18	24	1
T08-08FF90S	1/2	13/16 - 16	39.0	1.54	72.0	2.83	31.0	1.22	24	1
T08-10FF90S	1/2	1 - 14	39.0	1.54	72.0	2.83	34.0	1.34	30	13/16
T08-12FF90S	1/2	13/16 - 12	39.0	1.54	72.0	2.83	42.0	1.65	36	17/16
T10-10FF90S	5/8	1 - 14	45.0	1.77	81.0	3.19	35.0	1.38	30	13/16
T10-12FF90S	5/8	13/16 - 12	45.0	1.77	81.0	3.19	42.0	1.65	36	17/16
T12-12FF90S	3/4	13/16 - 12	55.0	2.17	95.0	3.74	45.0	1.77	36	17/16
T12-16FF90S	3/4	17/16 - 12	55.0	2.17	95.0	3.74	49.0	1.93	41	15/8
T16-16FF90S	1	17/16 - 12	71.0	2.79	122.0	4.80	55.0	2.17	41	15/8

Reference Hose Section for Coupling Compatibility

COUPLINGS

FF90L ORFS FEMALE SWIVEL - 90° ELBOW LONG DROP

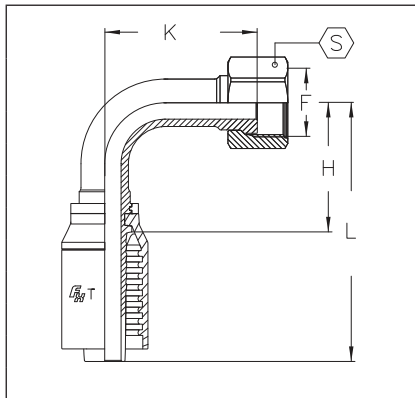

PART NUMBER	Hose Bore	F	H		L		K		S	
	INCH		[mm]	[in]	[mm]	[in]	[mm]	[in]	[mm]	[in]
T04-04FF90L	1/4	9/16 - 18	29.0	1.14	57.0	2.24	46.0	1.81	17	11/16
T04-06FF90L	1/4	11/16 - 16	27.0	1.06	55.0	2.16	54.0	2.12	22	7/8
T06-06FF90L	3/8	11/16 - 16	34.0	1.33	64.5	2.53	54.0	2.12	22	7/8
T06-08FF90L	3/8	13/16 - 16	34.0	1.33	64.5	2.53	64.0	2.51	24	1
T08-08FF90L	1/2	13/16 - 16	39.0	1.53	72.0	2.83	64.0	2.51	24	1
T08-10FF90L	1/2	1 - 14	39.0	1.53	72.0	2.83	70.0	2.75	30	13/16
T10-10FF90L	5/8	1 - 14	45.0	1.77	81.0	3.18	70.0	2.75	30	13/16
T12-12FF90L	3/4	13/16 - 12	55.0	2.17	95.0	3.70	96.0	3.77	36	17/16
T16-16FF90L	1	17/16 - 12	71.0	2.79	122.0	4.76	114.0	4.48	41	15/8

MA SAE 45° MALE

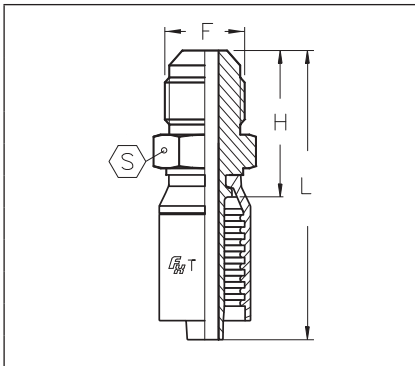

PART NUMBER	Hose Bore	F	H		L		S	
	INCH		[mm]	[in]	[mm]	[in]	[mm]	[in]
T06-06MA	3/8	5/8 - 18	28.2	1.11	58.7	2.21	16	5/8
T12-12MA	3/4	11/16 - 14	43.4	1.71	83.9	3.30	27	11/16

Reference Hose Section for Coupling Compatibility

COUPLINGS

FA SAE 45° FEMALE SWIVEL

PART NUMBER	Hose Bore	F	H		L		S		S1	
	INCH		[mm]	[in]	[mm]	[in]	[mm]	[in]	[mm]	[in]
T04-06FA	1/4	5/8 - 18	23.0	0.90	51.0	2.01	22	7/8	17	11/16
T06-06FA	3/8	5/8 - 18	23.5	0.92	54.0	2.12	22	7/8	16	5/8
T10-12FA	5/8	1 1/16 - 14	31.8	1.25	78.0	3.07	32	1 1/4	25	1
T12-12FA	3/4	1 1/16 - 14	31.8	1.25	72.3	3.27	32	1 1/4	27	1 1/16

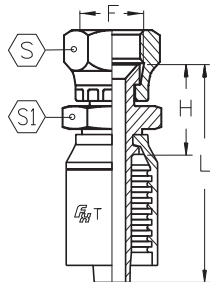

FA45 SAE 45° FEMALE SWIVEL - 45° ELBOW

PART NUMBER	Hose Bore	F	H		L		K		S	
	INCH		[mm]	[in]	[mm]	[in]	[mm]	[in]	[mm]	[in]
T06-06FA45	3/8	5/8 - 18	39	1.53	69.5	2.74	16	0.63	22	7/8
T12-12FA45	3/4	1 1/16 - 14	62	2.44	103.0	4.05	25	0.98	32	1 1/4

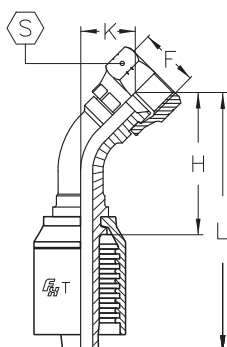

FA90 SAE 45° FEMALE SWIVEL - 90° ELBOW

PART NUMBER	Hose Bore	F	H		L		K		S	
	INCH		[mm]	[in]	[mm]	[in]	[mm]	[in]	[mm]	[in]
T06-06FA90	3/8	5/8 - 18	31	1.22	61	2.40	31	1.22	22	7/8
T12-12FA90	3/4	1 1/16 - 14	55	2.16	95	3.74	51	2.01	32	1 1/4

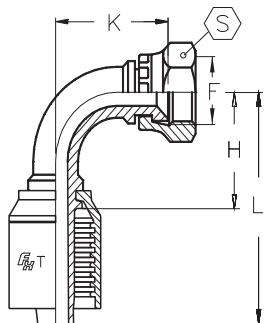

Reference Hose Section for Coupling Compatibility

COUPLINGS

MOB O-RING BOSS MALE

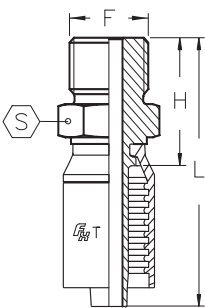

PART NUMBER	Hose Bore	F	H		L		S	
	INCH		[mm]	[in]	[mm]	[in]	[mm]	[in]
T04-04MOB	1/4	7/16 - 20	21.7	0.85	49.7	1.96	14	9/16
T04-05MOB	1/4	1/2 - 20	22.2	0.87	50.2	1.98	16	5/8
T04-06MOB	1/4	9/16 - 18	23.5	0.92	51.5	2.03	17	11/16
T06-06MOB	3/8	9/16 - 18	23.5	0.92	54.0	2.12	17	11/16
T06-08MOB	3/8	3/4 - 16	26.2	1.03	56.7	2.23	22	7/8
T06-10MOB	3/8	7/8 - 14	28.0	1.10	58.5	2.30	25	1
T08-08MOB	1/2	3/4 - 16	27.2	1.07	60.2	2.37	22	7/8
T08-10MOB	1/2	7/8 - 14	29.7	1.17	62.7	2.47	25	1
T08-12MOB	1/2	1 1/16 - 12	33.6	1.32	66.6	2.62	32	1 1/4
T10-10MOB	5/8	7/8 - 14	29.9	1.18	65.7	2.59	25	1
T10-12MOB	5/8	1 1/16 - 12	33.8	1.33	69.6	2.74	32	1 1/4
T12-12MOB	3/4	1 1/16 - 12	34.6	1.36	75.1	2.96	32	1 1/4
T12-16MOB	3/4	1 5/16 - 12	36.1	1.42	76.6	3.01	38	1 1/2
T16-16MOB	1	1 5/16 - 12	37.6	1.48	88.6	3.49	38	1 1/2

MIX SAE INVERTED FLARE MALE SWIVEL

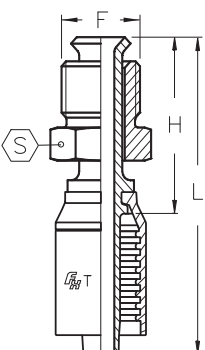

PART NUMBER	Hose Bore	F	H		L		S	
	INCH		[mm]	[in]	[mm]	[in]	[mm]	[in]
T04-03MIX	1/4	3/8 - 24	38.3	1.51	66.8	2.63	9.5	3/8
T04-04MIX	1/4	7/16 - 24	39.1	1.54	67.8	2.67	11.1	7/16
T04-05MIX	1/4	1/2 - 20	42.2	1.66	70.6	2.78	12.0	1/2
T06-04MIX	3/8	7/16 - 24	39.9	1.57	70.6	2.78	11.1	7/16
T06-05MIX	3/8	1/2 - 20	42.4	1.67	73.1	2.88	12.0	1/2
T06-06MIX	3/8	5/8 - 18	43.7	1.72	74.4	2.93	16.0	5/8
T06-07MIX	3/8	1 1/16 - 18	45.7	1.80	76.2	3.00	17.0	1 1/16
T06-08MIX	3/8	3/4 - 18	48.5	1.91	79.2	3.12	19.0	3/4
T08-08MIX	1/2	3/4 - 18	49.0	1.93	82.3	3.24	19.0	3/4
T08-10MIX	1/2	7/8 - 18	52.3	2.06	85.6	3.37	22.0	7/8

MIX45 SAE INVERTED FLARE MALE SWIVEL - 45° ELBOW

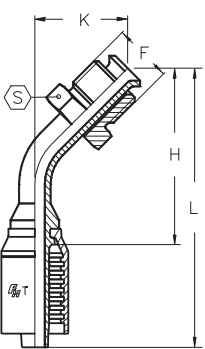

PART NUMBER	Hose Bore	F	H		L		K		S	
	INCH		[mm]	[in]	[mm]	[in]	[mm]	[in]	[mm]	[in]
T04-03MIX45	1/4	3/8 - 24	41.6	1.64	70.1	2.76	13.5	0.53	9.5	3/8
T04-04MIX45	1/4	7/16 - 24	51.8	2.04	80.3	3.16	14.5	0.57	11.1	7/16
T04-05MIX45	1/4	1/2 - 20	52.1	2.05	81.5	3.21	16.5	0.65	12.0	1/2
T06-04MIX45	3/8	7/16 - 24	52.1	2.05	82.6	3.25	14.5	0.57	11.1	7/16
T06-05MIX45	3/8	1/2 - 20	50.0	1.97	80.5	3.17	16.5	0.65	12.0	1/2
T06-06MIX45	3/8	5/8 - 18	52.6	2.07	83.0	3.27	18.0	0.71	16.0	5/8
T06-07MIX45	3/8	1 1/16 - 18	57.4	2.26	87.9	3.46	19.3	0.76	17.0	1 1/16
T06-08MIX45	3/8	3/4 - 18	63.0	2.48	93.5	3.68	21.6	0.85	19.0	3/4
T08-08MIX45	1/2	3/4 - 18	64.8	2.55	97.8	3.85	21.6	0.85	19.0	3/4

Reference Hose Section for Coupling Compatibility

COUPLINGS

MIX90

SAE INVERTED FLARE MALE SWIVEL - 90° ELBOW

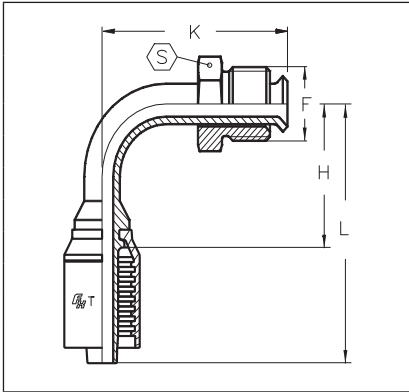

PART NUMBER	Hose Bore	F	H		L		K		S	
	INCH		[mm]	[in]	[mm]	[in]	[mm]	[in]	[mm]	[in]
T04-03MIX90	1/4	3/8 - 24	32.5	1.28	61.0	2.40	24.6	0.97	9.5	3/8
T04-04MIX90	1/4	7/16 - 24	40.4	1.59	68.8	2.71	27.9	1.10	11.1	7/16
T04-05MIX90	1/4	1/4 - 20	42.7	1.68	71.1	2.80	32.5	1.28	12.0	1/2
T06-04MIX90	3/8	7/16 - 24	40.6	1.60	71.1	2.80	27.9	1.10	11.1	7/16
T06-05MIX90	3/8	1/2 - 20	43.4	1.71	73.9	2.91	32.5	1.28	12.0	1/2
T06-06MIX90	3/8	5/8 - 18	48.3	1.90	78.7	3.10	36.8	1.45	16.0	5/8
T06-07MIX90	3/8	11/16 - 18	53.3	2.10	83.8	3.30	40.6	1.60	17.0	11/16
T06-08MIX90	3/8	3/4 - 18	55.6	2.19	86.1	3.39	45.2	1.78	19.0	3/4
T08-08MIX90	1/2	3/4 - 18	56.1	2.21	89.1	3.51	45.2	1.78	19.0	3/4

MRNS

SAE FLARELESS MALE ASSEMBLY

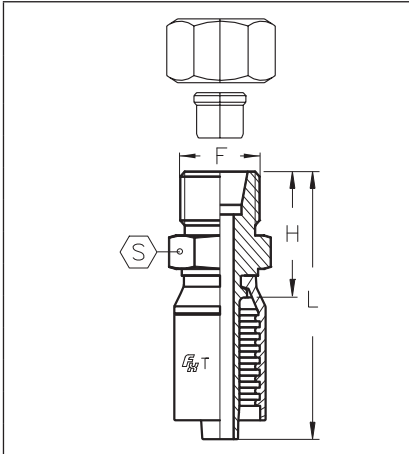

PART NUMBER	Hose Bore	F	H		L		S		S1	
	INCH		[mm]	[in]	[mm]	[in]	[mm]	[in]	[mm]	[in]
T04-04MRNS	1/4	7/16 - 20	24.0	0.94	51.0	2.01	14	9/16	14	9/16
T04-05MRNS	1/4	1/2 - 20	25.3	1.00	53.0	2.09	17	11/16	16	5/8
T06-05MRNS	3/8	1/2 - 20	26.0	1.02	55.6	2.19	17	11/16	16	5/8
T06-06MRNS	3/8	9/16 - 18	26.8	1.05	55.6	2.19	17	11/16	17	11/16
T06-08MRNS	3/8	3/4 - 16	30.0	1.18	58.5	2.30	19	3/4	22	7/8
T08-08MRNS	1/2	3/4 - 16	30.4	1.20	61.3	2.41	19	3/4	22	7/8
T08-10MRNS	1/2	7/8 - 14	32.3	1.27	63.4	2.50	24	1	25	1
T12-12MRNS	3/4	1 1/16 - 12	35.7	1.40	74.7	2.94	27	1 1/16	32	1 1/4

Reference Hose Section for Coupling Compatibility

COUPLINGS

FJIS JIS FEMALE SWIVEL (TOYOTA)

PART NUMBER	Hose Bore	F	H		L		S		S1	
	INCH		[mm]	[in]	[mm]	[in]	[mm]	[in]	[mm]	[in]
	T04-04FJIS		1/4	1/4 - 19	24	0.94	52	2.05	19	3/4
T06-06FJIS	3/8	3/8 - 19	26	1.02	57	2.24	22	7/8	17	11/16
T08-08FJIS	1/2	1/2 - 14	30	1.18	63	2.48	27	1 1/16	22	7/8
T12-12FJIS	3/4	3/4 - 14	36	1.42	76	2.99	32	1 1/4	27	1 1/16
T16-16FJIS	1	1 - 11	40	1.57	91	3.58	41	1 5/8	32	1 1/4

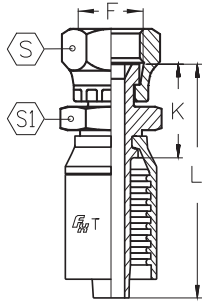

MBSPT BSPT MALE

PART NUMBER	Hose Bore	F	H		L		S	
	INCH		[mm]	[in]	[mm]	[in]	[mm]	[in]
	T04-02MBSPT		1/4	1/8 - 28	21	0.83	49	1.93
T04-04MBSPT	1/4	1/4 - 19	25	0.98	53	2.09	15	5/8
T04-06MBSPT	1/4	3/8 - 19	26	1.02	54	2.12	19	3/4
T05-06MBSPT	5/16	3/8 - 19	26	1.02	54	2.12	19	3/4
T06-04MBSPT	3/8	1/4 - 19	26	1.02	56	2.20	15	5/8
T06-06MBSPT	3/8	3/8 - 19	27	1.06	57	2.24	19	3/4
T06-08MBSPT	3/8	1/2 - 14	32	1.26	63	2.48	22	7/8
T08-06MBSPT	1/2	3/8 - 19	28	1.10	61	2.52	19	3/4
T08-08MBSPT	1/2	1/2 - 14	33	1.30	66	2.60	22	7/8
T10-12MBSPT	5/8	3/4 - 14	35	1.38	71	2.79	27	1 1/16
T12-12MBSPT	3/4	3/4 - 14	36	1.41	77	3.03	27	1 1/16
T16-16MBSPT	1	1 - 11	43	1.69	94	3.70	36	1 7/16

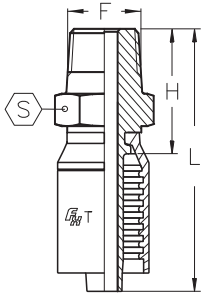

Reference Hose Section for Coupling Compatibility

COUPLINGS

MBSPP BSPP MALE

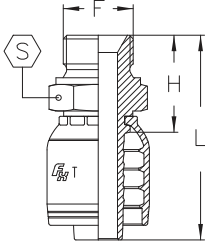

PART NUMBER	Hose Bore	F	H		L		S	
	INCH		[mm]	[in]	[mm]	[in]	[mm]	[in]
T04-02MBSPP	1/4	1/8 - 28	20	0.79	48	1.89	14	9/16
T04-04MBSPP	1/4	1/4 - 19	25	0.98	53	2.09	19	3/4
T04-06MBSPP	1/4	3/8 - 19	27	1.06	55	2.16	22	7/8
T05-06MBSPP	5/16	3/8 - 19	27	1.06	55	2.16	22	7/8
T06-04MBSPP	3/8	1/4 - 28	25	0.98	55	2.16	19	3/4
T06-06MBSPP	3/8	3/8 - 19	27	1.06	58	2.28	22	7/8
T06-08MBSPP	3/8	1/2 - 14	32	1.26	62	2.44	27	1 1/16
T08-06MBSPP	1/2	3/8 - 19	28	1.10	61	2.40	22	7/8
T08-08MBSPP	1/2	1/2 - 14	33	1.30	66	2.60	27	1 1/16
T08-10MBSPP	1/2	5/8 - 14	35	1.38	68	2.68	30	1 3/16
T08-12MBSPP	1/2	3/4 - 14	36	1.42	69	2.72	32	1 1/4
T10-10MBSPP	5/8	5/8 - 14	35	1.38	71	2.79	30	1 3/16
T10-12MBSPP	5/8	3/4 - 14	36	1.42	72	2.83	32	1 1/4
T12-12MBSPP	3/4	3/4 - 14	37	1.46	77	3.03	32	1 1/4
T12-16MBSPP	3/4	1 - 11	42	1.65	82	3.23	41	1 5/8
T16-16MBSPP	1	1 - 11	43	1.69	94	3.70	41	1 5/8

FBSP BSPP FEMALE SWIVEL

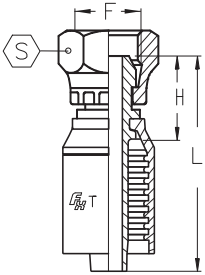

PART NUMBER	Hose Bore	F	H		L		S	
	INCH		[mm]	[in]	[mm]	[in]	[mm]	[in]
T04-02FBSP	1/4	1/8 - 28	17	0.67	45	1.77	14	9/16
T04-04FBSP	1/4	1/4 - 19	19	0.75	47	1.85	19	3/4
T04-06FBSP	1/4	3/8 - 19	22	0.87	50	1.97	22	7/8
T05-06FBSP	5/16	3/8 - 19	22	0.87	50	1.97	22	7/8
T05-08FBSP	5/16	1/2 - 14	23	0.90	51	2.01	27	1 1/16
T06-04FBSP	3/8	1/4 - 19	19	0.75	49	1.93	19	3/4
T06-06FBSP	3/8	3/8 - 19	21	0.83	51	2.01	22	7/8
T06-08FBSP	3/8	1/2 - 14	23	0.90	54	2.12	27	1 1/16
T08-06FBSP	1/2	3/8 - 19	22	0.87	56	2.20	22	7/8
T08-08FBSP	1/2	1/2 - 14	23	0.90	56	2.20	27	1 1/16
T08-10FBSP	1/2	5/8 - 14	24	0.94	57	2.24	30	1 3/16
T08-12FBSP	1/2	3/4 - 14	27	1.06	60	2.36	32	1 1/4
T10-10FBSP	5/8	5/8 - 14	23	0.90	59	2.32	30	1 3/16
T10-12FBSP	5/8	3/4 - 14	27	1.06	63	2.48	32	1 1/4
T12-12FBSP	3/4	3/4 - 14	27	1.06	67	2.64	32	1 1/4
T12-16FBSP	3/4	1 - 11	30	1.18	70	2.75	41	1 5/8
T16-12FBSP	1	3/4 - 14	28	1.10	79	3.11	32	1 1/4
T16-16FBSP	1	1 - 11	30	1.18	81	3.19	41	1 5/8

Reference Hose Section for Coupling Compatibility

COUPLINGS

FBSP45 BSPP FEMALE SWIVEL - 45° ELBOW

PART NUMBER	Hose Bore	F	H		L		K		S	
	INCH		[mm]	[in]	[mm]	[in]	[mm]	[in]	[mm]	[in]
	T04-02FBSP45	1/4	1/8 - 28	36	1.42	64	2.52	16	0.63	14
T04-04FBSP45	1/4	1/4 - 19	37	1.46	65	2.56	16	0.63	19	3/4
T04-06FBSP45	1/4	3/8 - 19	40	1.57	68	2.68	19	0.75	22	7/8
T05-06FBSP45	5/16	3/8 - 19	41	1.61	69	2.72	19	0.75	22	7/8
T06-06FBSP45	3/8	3/8 - 19	42	1.65	73	2.87	19	0.75	22	7/8
T06-08FBSP45	3/8	1/2 - 14	44	1.73	75	2.95	21	0.83	27	1 1/16
T08-08FBSP45	1/2	1/2 - 14	49	1.93	82	3.23	22	0.87	27	1 1/16
T08-10FBSP45	1/2	5/8 - 14	49	1.93	82	3.23	22	0.87	30	1 3/16
T10-10FBSP45	5/8	5/8 - 14	54	2.12	90	3.54	24	0.94	30	1 3/16
T10-12FBSP45	5/8	3/4 - 14	57	2.24	93	3.66	26	1.02	32	1 1/4
T12-12FBSP45	3/4	3/4 - 14	66	2.60	106	4.17	28	1.10	32	1 1/4
T16-16FBSP45	1	1 - 11	84	3.31	135	5.31	36	1.42	41	1 5/8

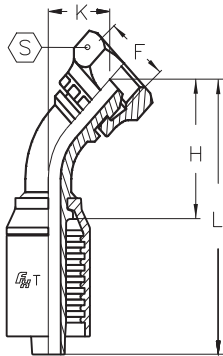

FBSP90 BSPP FEMALE SWIVEL - 90° ELBOW

PART NUMBER	Hose Bore	F	H		L		K		S	
	INCH		[mm]	[in]	[mm]	[in]	[mm]	[in]	[mm]	[in]
	T04-02FBSP90	1/4	1/8 - 28	26	1.02	54	2.12	28	1.10	14
T04-04FBSP90	1/4	1/4 - 19	26	1.02	54	2.12	28	1.10	19	3/4
T04-06FBSP90	1/4	3/8 - 19	26	1.02	54	2.12	32	1.26	22	7/8
T05-06FBSP90	5/16	3/8 - 19	28	1.10	56	2.20	34	1.34	22	7/8
T06-06FBSP90	3/8	3/8 - 19	31	1.22	61	2.40	35	1.38	22	7/8
T06-08FBSP90	3/8	1/2 - 14	31	1.22	61	2.40	38	1.50	27	1 1/16
T08-08FBSP90	1/2	1/2 - 14	37	1.46	70	2.75	42	1.65	27	1 1/16
T08-10FBSP90	1/2	5/8 - 14	37	1.46	70	2.75	43	1.69	30	1 3/16
T10-10FBSP90	5/8	5/8 - 14	45	1.77	80	3.15	46	1.81	30	1 3/16
T10-12FBSP90	5/8	3/4 - 14	45	1.77	80	3.15	50	1.97	32	1 1/4
T12-12FBSP90	3/4	3/4 - 14	54	2.12	95	3.74	56	2.20	32	1 1/4
T12-16FBSP90	3/4	1 - 11	54	2.12	95	3.74	59	2.32	41	1 5/8
T16-12FBSP90	1	3/4 - 14	70	2.76	121	4.76	75	2.95	32	1 1/4
T16-16FBSP90	1	1 - 11	70	2.76	121	4.76	72	2.83	41	1 5/8

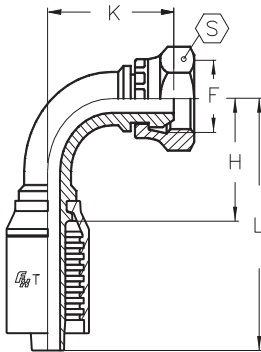

Reference Hose Section for Coupling Compatibility

COUPLINGS

FML FEMALE METRIC LIGHT SWIVEL (24° CONE SEAT) - DKOL

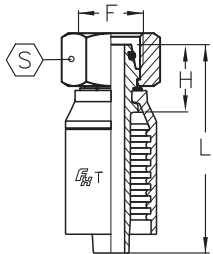

PART NUMBER	Hose Bore	F	Tube	H		L		S	
	INCH			[mm]	[in]	[mm]	[in]	[mm]	[in]
T04-12FML	1/4	M12 x 1.5	L6	23	0.90	51	2.01	17	11/16
T04-14FML	1/4	M14 x 1.5	L8	22	0.87	50	1.97	17	11/16
T04-16FML	1/4	M16 x 1.5	L10	24	0.94	52	2.05	19	3/4
T04-18FML	1/4	M18 x 1.5	L12	24	0.94	52	2.05	22	7/8
T05-16FML	5/16	M16 x 1.5	L10	24	0.94	52	2.05	19	3/4
T05-18FML	5/16	M18 x 1.5	L12	24	0.94	52	2.05	22	7/8
T06-16FML	3/8	M16 x 1.5	L10	23	0.90	54	2.12	19	3/4
T06-18FML	3/8	M18 x 1.5	L12	24	0.94	54	2.12	22	7/8
T06-22FML	3/8	M22 x 1.5	L15	24	0.94	54	2.12	27	11/16
T08-22FML	1/2	M22 x 1.5	L15	24	0.94	57	2.24	27	11/16
T08-26FML	1/2	M26 x 1.5	L18	26	1.02	59	2.32	32	11/4
T10-26FML	5/8	M26 x 1.5	L18	27	1.06	62	2.44	32	11/4
T10-30FML	5/8	M30 x 2.0	L22	28	1.10	64	2.52	36	17/16
T12-26FML	3/4	M26 x 1.5	L18	34	1.34	75	2.95	32	11/4
T12-30FML	3/4	M30 x 2.0	L22	31	1.22	71	2.79	36	17/16
T16-36FML	1	M36 x 2.0	L28	32	1.26	83	3.27	41	15/8

SP STANDPIPE STRAIGHT

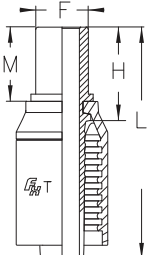

PART NUMBER	Hose Bore	E		H		M		L	
	INCH	[mm]	[in]	[mm]	[in]	[mm]	[in]	[mm]	[in]
T04-04SP	1/4	6.3	1/4	30.5	1.20	23.5	0.92	58.5	2.30
T06-06SP	3/8	9.5	3/8	32.0	1.26	25.0	0.98	62.5	2.46
T08-08SP	1/2	12.7	1/2	32.5	1.28	25.0	0.98	65.5	2.58
T08-10SP	1/2	15.9	5/8	43.0	1.69	35.5	1.40	76.0	2.99
T12-12SP	3/4	19.0	3/4	44.5	1.75	36.0	1.42	85.0	3.35
T16-16SP	1	25.4	1	49.5	1.95	40.0	1.57	10.5	0.41

Reference Hose Section for Coupling Compatibility

COUPLINGS

MP NPT MALE

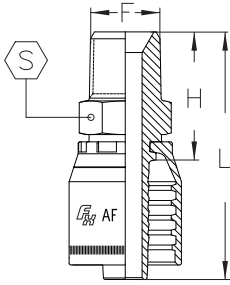

PART NUMBER	Hose Bore	F	H		L		S	
	INCH		[mm]	[in]	[mm]	[in]	[mm]	[in]
AF03-02MP	3/16	1/8 - 27	20.6	0.81	45.6	1.79	12	1/2
AF03-04MP	3/16	1/4 - 18	26.5	1.04	51.5	2.03	14	9/16
AF04-02MP	1/4	1/8 - 27	21.1	0.83	49.1	1.93	12	1/2
AF04-04MP	1/4	1/4 - 18	27.0	1.06	55.0	2.16	14	9/16
AF04-06MP	1/4	3/8 - 18	28.6	1.12	56.6	2.23	19	3/4
AF04-08MP	1/4	1/2 - 14	34.0	1.34	62.0	2.44	22	7/8
AF05-04MP	5/16	1/4 - 18	27.0	1.06	55.0	2.16	14	9/16
AF05-06MP	5/16	3/8 - 18	28.6	1.12	56.6	2.23	19	3/4
AF06-04MP	3/8	1/4 - 18	27.5	1.08	58.0	2.28	16	5/8
AF06-06MP	3/8	3/8 - 18	28.6	1.12	59.1	2.33	19	3/4
AF06-08MP	3/8	1/2 - 14	34.0	1.34	64.5	2.54	22	7/8
AF08-04MP	1/2	1/4 - 18	30.5	1.20	63.2	2.49	22	7/8
AF08-06MP	1/2	3/8 - 18	30.6	1.20	63.6	2.50	22	7/8
AF08-08MP	1/2	1/2 - 14	35.0	1.38	68.0	2.68	22	7/8
AF08-12MP	1/2	3/4 - 14	36.9	1.45	69.9	2.75	27	1 1/16
AF10-08MP	5/8	1/2 - 14	36.2	1.42	72.0	2.83	25	1
AF10-12MP	5/8	3/4 - 14	37.1	1.46	72.9	2.87	27	1 1/16
AF12-08MP	3/4	1/2 - 14	37.5	1.48	78.0	3.07	27	1 1/16
AF12-12MP	3/4	3/4 - 14	37.9	1.49	78.4	3.09	27	1 1/16
AF12-16MP	3/4	1 - 11 1/2	45.5	1.79	86.0	3.38	35	1 7/16
AF16-12MP	1	3/4 - 14	40.4	1.59	91.4	3.60	32	1 1/4
AF16-16MP	1	1 - 11 1/2	47.0	1.85	98.0	3.86	35	1 7/16
AF16-20MP	1	1 1/4 - 11 1/2	51.1	2.01	102.1	4.02	46	1 13/16

MPX NPT MALE SWIVEL

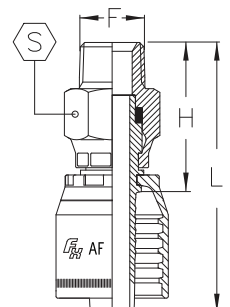

PART NUMBER	Hose Bore	F	H		L		S	
	INCH		[mm]	[in]	[mm]	[in]	[mm]	[in]
AF04-04MPX	1/4	1/4 - 18	41	1.61	69	2.72	17	11/16
AF04-06MPX	1/4	3/8 - 18	46	1.81	74	2.91	22	7/8
AF06-04MPX	3/8	1/4 - 18	41	1.61	72	2.83	17	11/16
AF06-06MPX	3/8	3/8 - 18	45	1.77	75	2.95	22	7/8
AF06-08MPX	3/8	1/2 - 14	57	2.24	88	3.46	27	1 1/16
AF08-06MPX	1/2	3/8 - 18	46	1.81	79	3.11	22	7/8
AF08-08MPX	1/2	1/2 - 14	56	2.20	89	3.50	27	1 1/16
AF12-08MPX	3/4	1/2 - 14	57	2.24	98	3.86	27	1 1/16
AF12-12MPX	3/4	3/4 - 14	61	2.40	101	3.98	34	1 3/8
AF16-16MPX	1	1 - 11 1/2	65	2.56	116	4.57	38	1 1/2

Reference Hose Section for Coupling Compatibility

COUPLINGS

FP NPT FEMALE RIGID

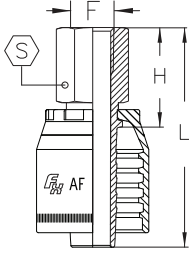

PART NUMBER	Hose Bore	F	H		L		S	
	INCH		[mm]	[in]	[mm]	[in]	[mm]	[in]
AF04-02FP	1/4	1/8 - 27	21.5	0.85	49.5	1.95	16	5/8
AF04-04FP	1/4	1/4 - 18	27.1	1.07	55.1	2.17	19	3/4
AF04-06FP	1/4	3/8 - 18	28.4	1.12	56.4	2.22	22	7/8
AF06-04FP	3/8	1/4 - 18	27.1	1.07	57.6	2.27	19	3/4
AF06-06FP	3/8	3/8 - 18	28.4	1.12	58.9	2.32	22	7/8
AF06-08FP	3/8	1/2 - 14	34.5	1.36	65.0	2.56	29	1 3/16
AF08-08FP	1/2	1/2 - 14	35.5	1.40	68.5	2.70	29	1 3/16
AF12-12FP	3/4	3/4 - 14	38.0	1.50	78.5	3.09	32	1 1/4

FPX NPSM FEMALE SWIVEL (60° CONE SEAT)

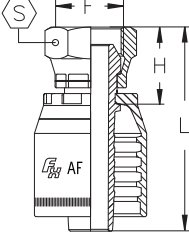

PART NUMBER	Hose Bore	F	H		L		S	
	INCH		[mm]	[in]	[mm]	[in]	[mm]	[in]
AF04-04FPX	1/4	1/4 - 18	19	0.75	47	1.85	17	1 1/16
AF06-06FPX	3/8	3/8 - 18	21	0.83	51	2.00	22	7/8
AF08-08FPX	1/2	1/2 - 14	23	0.90	56	2.20	25	1
AF12-12FPX	3/4	3/4 - 14	27	1.06	67	2.64	32	1 1/4
AF16-16FPX	1	1 - 11 1/2	30	1.18	81	3.19	38	1 1/2

MJ JIC 37° MALE

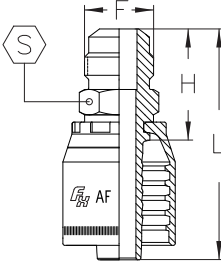

PART NUMBER	Hose Bore	F	H		L		S	
	INCH		[mm]	[in]	[mm]	[in]	[mm]	[in]
AF03-04MJ	3/16	7/16 - 20	25.0	0.98	50.0	1.97	12	1/2
AF04-04MJ	1/4	7/16 - 20	25.5	1.00	53.5	2.11	12	1/2
AF04-05MJ	1/4	1/2 - 20	25.5	1.00	53.5	2.11	14	9/16
AF04-06MJ	1/4	9/16 - 18	26.6	1.05	54.6	2.15	15	5/8
AF05-05MJ	5/16	1/2 - 20	25.5	1.00	53.5	2.11	14	9/16
AF05-06MJ	5/16	9/16 - 18	26.6	1.05	54.6	2.15	15	5/8
AF06-06MJ	3/8	9/16 - 18	26.6	1.05	57.1	2.25	15	5/8
AF06-08MJ	3/8	3/4 - 16	29.7	1.17	60.2	2.37	19	3/4
AF06-10MJ	3/8	7/8 - 14	34.3	1.35	64.8	2.55	24	1
AF08-06MJ	1/2	9/16 - 18	29.7	1.17	62.6	2.46	19	3/4
AF08-08MJ	1/2	3/4 - 16	30.7	1.21	63.7	2.51	19	3/4
AF08-10MJ	1/2	7/8 - 14	35.3	1.39	68.3	2.69	24	1
AF08-12MJ	1/2	1 1/16 - 12	38.9	1.53	71.9	2.83	27	1 1/16
AF10-08MJ	5/8	3/4 - 16	33.7	1.33	68.4	2.69	24	1
AF10-10MJ	5/8	7/8 - 14	35.5	1.40	71.3	2.81	24	1
AF10-12MJ	5/8	1 1/16 - 12	39.1	1.54	74.9	2.95	27	1 1/16
AF12-10MJ	3/4	7/8 - 14	37.3	1.47	77.8	3.06	27	1 1/16
AF12-12MJ	3/4	1 1/16 - 12	39.9	1.57	80.4	3.16	27	1 1/16
AF12-14MJ	3/4	1 3/16 - 12	41.6	1.64	82.1	3.23	32	1 1/4
AF12-16MJ	3/4	1 5/16 - 12	42.1	1.66	82.6	3.25	34	1 3/8
AF16-16MJ	1	1 5/16 - 12	43.6	1.72	94.6	3.72	34	1 3/8
AF16-20MJ	1	1 5/8 - 12	46.8	1.84	97.8	3.85	42	1 1/2

Reference Hose Section for Coupling Compatibility

COUPLINGS

FJ JIC 37° FEMALE SWIVEL

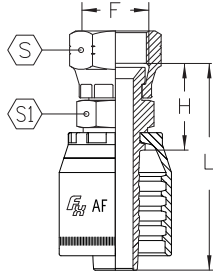

PART NUMBER	Hose Bore INCH	F	H		L		S		S1	
			[mm]	[in]	[mm]	[in]	[mm]	[in]	[mm]	[in]
AF03-04FJ	3/16	7/16 - 20	19.0	0.75	44.0	1.73	14	9/16	12	1/2
AF04-04FJ	1/4	7/16 - 20	20.5	0.81	48.5	1.91	14	9/16	14	9/16
AF04-05FJ	1/4	1/2 - 20	21.0	0.83	49.0	1.93	17	11/16	14	9/16
AF04-06FJ	1/4	9/16 - 18	22.0	0.87	50.0	1.97	19	3/4	14	9/16
AF05-05FJ	5/16	1/2 - 20	21.0	0.83	49.0	1.93	17	11/16	14	9/16
AF05-06FJ	5/16	9/16 - 18	22.5	0.88	50.5	1.99	19	3/4	16	5/8
AF06-04FJ	3/8	7/16 - 20	21.0	0.83	51.5	2.03	14	9/16	16	5/8
AF06-05FJ	3/8	1/2 - 20	21.5	0.85	52.0	2.05	17	11/16	16	5/8
AF06-06FJ	3/8	9/16 - 18	22.5	0.88	53.0	2.09	19	3/4	16	5/8
AF06-08FJ	3/8	3/4 - 16	24.5	0.96	55.0	2.16	22	7/8	19	3/4
AF06-10FJ	3/8	7/8 - 14	36.5	1.44	57.0	2.24	27	1 1/16	22	7/8
AF08-06FJ	1/2	9/16 - 18	24.5	0.96	57.5	2.26	19	3/4	19	3/4
AF08-08FJ	1/2	3/4 - 16	25.5	1.00	58.5	2.30	22	7/8	19	3/4
AF08-10FJ	1/2	7/8 - 14	27.5	1.08	60.5	2.38	27	1 1/16	22	7/8
AF08-12FJ	1/2	1 1/16 - 12	30.3	1.19	63.3	2.49	32	1 1/4	25	1
AF10-08FJ	5/8	3/4 - 16	26.7	1.05	62.5	2.46	22	7/8	22	7/8
AF10-10FJ	5/8	7/8 - 14	27.7	1.09	63.5	2.50	27	1 1/16	22	7/8
AF10-12FJ	5/8	1 1/16 - 12	30.5	1.20	66.3	2.61	32	1 1/4	25	1
AF12-10FJ	3/4	7/8 - 14	30.0	1.18	70.5	2.77	27	1 1/16	27	1 1/16
AF12-12FJ	3/4	1 1/16 - 12	31.8	1.25	72.3	2.85	32	1 1/4	27	1 1/16
AF12-14FJ	3/4	1 3/16 - 12	34.5	1.36	75.0	2.95	36	1 7/16	30	1 3/16
AF12-16FJ	3/4	1 5/16 - 12	35.5	1.40	76.0	2.99	38	1 1/2	32	1 1/4
AF16-12FJ	1	1 1/16 - 12	34.3	1.35	85.3	3.36	32	1 1/4	32	1 1/4
AF16-16FJ	1	1 5/16 - 12	37.0	1.46	88.0	3.46	38	1 1/2	32	1 1/4
AF16-20FJ	1	1 5/8 - 12	42.0	1.65	93.0	3.66	50	2	41	1 5/8

Reference Hose Section for Coupling Compatibility

COUPLINGS

FJ45

JIC 37° FEMALE SWIVEL - 45° ELBOW

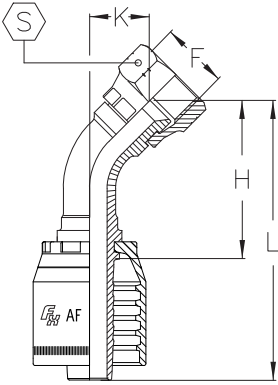

PART NUMBER	Hose Bore	F	H		L		K		S	
	INCH		[mm]	[in]	[mm]	[in]	[mm]	[in]	[mm]	[in]
AF03-04FJ45	3/16	7/16 - 20	29.0	1.14	54	2.12	10.0	0.39	14	9/16
AF04-04FJ45	1/4	7/16 - 20	31.0	1.22	59	2.32	10.0	0.39	14	9/16
AF04-05FJ45	1/4	1/2 - 20	32.0	1.26	60	2.36	11.0	0.43	17	11/16
AF04-06FJ45	1/4	9/16 - 18	33.0	1.30	61	2.40	12.0	0.47	19	3/4
AF05-05FJ45	5/16	1/2 - 20	33.0	1.30	61	2.40	11.0	0.43	17	11/16
AF05-06FJ45	5/16	9/16 - 18	34.0	1.34	62	2.44	12.0	0.47	19	3/4
AF06-06FJ45	3/8	9/16 - 18	35.5	1.40	66	2.60	12.0	0.47	19	3/4
AF06-08FJ45	3/8	3/4 - 16	37.5	1.48	68	2.68	14.0	0.55	22	7/8
AF08-08FJ45	1/2	3/4 - 16	41.0	1.61	74	2.91	14.5	0.57	22	7/8
AF08-10FJ45	1/2	7/8 - 14	43.0	1.69	76	2.99	16.0	0.63	27	11/16
AF08-12FJ45	1/2	1 1/16 - 12	45.5	1.79	79	3.09	19.0	0.75	32	1 1/4
AF10-10FJ45	5/8	7/8 - 14	47.0	1.85	83	3.27	16.0	0.63	27	1 1/16
AF10-12FJ45	5/8	1 1/16 - 12	50.0	1.97	86	3.38	19.0	0.75	32	1 1/4
AF12-12FJ45	3/4	1 1/16 - 12	57.0	2.24	97	3.82	20.0	0.79	32	1 1/4
AF12-14FJ45	3/4	1 3/16 - 12	59.0	2.32	100	3.94	22.0	0.87	36	1 7/16
AF12-16FJ45	3/4	1 5/16 - 12	61.0	2.40	101	3.98	24.0	0.94	38	1 1/2
AF16-16FJ45	1	1 5/16 - 12	72.0	2.83	123	4.84	24.0	0.94	38	1 1/2
AF16-20FJ45	1	1 5/8 - 12	76.0	2.99	127	5.00	28.0	1.10	50	2

FJ90S

JIC 37° FEMALE SWIVEL - 90° ELBOW SHORT DROP

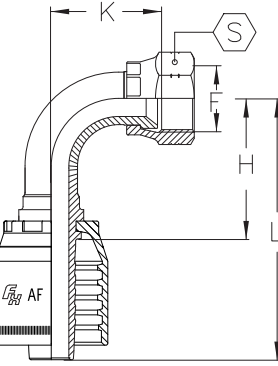

PART NUMBER	Hose Bore	F	H		L		K		S	
	INCH		[mm]	[in]	[mm]	[in]	[mm]	[in]	[mm]	[in]
AF03-04FJ90S	3/16	7/16 - 20	21.0	0.83	46.0	1.81	18	0.71	14	9/16
AF04-04FJ90S	1/4	7/16 - 20	25.5	1.00	53.5	2.11	20	0.79	14	9/16
AF04-05FJ90S	1/4	1/2 - 20	25.5	1.00	53.5	2.11	21	0.83	17	11/16
AF04-06FJ90S	1/4	9/16 - 18	25.5	1.00	53.5	2.11	23	0.90	19	3/4
AF05-05FJ90S	5/16	1/2 - 20	28.0	1.10	56.0	2.20	22	0.87	17	11/16
AF05-06FJ90S	5/16	9/16 - 18	28.0	1.10	56.0	2.20	24	0.94	19	3/4
AF06-06FJ90S	3/8	9/16 - 18	30.0	1.18	60.5	2.38	23	0.90	19	3/4
AF06-08FJ90S	3/8	3/4 - 16	31.0	1.22	61.5	2.42	29	1.14	22	7/8
AF08-08FJ90S	1/2	3/4 - 16	37.0	1.46	70.0	2.75	29	1.14	22	7/8
AF08-10FJ90S	1/2	7/8 - 14	38.0	1.50	71.0	2.79	33	1.30	27	1 1/16
AF08-12FJ90S	1/2	1 1/16 - 12	40.0	1.57	73.0	2.87	40	1.57	32	1 1/4
AF10-10FJ90S	5/8	7/8 - 14	43.0	1.69	79.0	3.11	32	1.26	27	1 1/16
AF10-12FJ90S	5/8	1 1/16 - 12	45.0	1.77	81.0	3.19	40	1.57	32	1 1/4
AF12-12FJ90S	3/4	1 1/16 - 12	55.0	2.16	95.0	3.74	43	1.69	32	1 1/4
AF12-14FJ90S	3/4	1 3/16 - 12	55.0	2.16	95.0	3.74	47	1.85	36	1 7/16
AF12-16FJ90S	3/4	1 5/16 - 12	55.0	2.16	95.0	3.74	49	1.93	38	1 1/2
AF16-16FJ90S	1	1 5/16 - 12	71.0	2.79	122.0	4.80	56	2.20	38	1 1/2
AF16-20FJ90S	1	1 5/8 - 12	71.0	2.79	122.0	4.80	61	2.40	50	2

Reference Hose Section for Coupling Compatibility

COUPLINGS

FJ90M

JIC 37° FEMALE SWIVEL - 90° ELBOW MEDIUM DROP

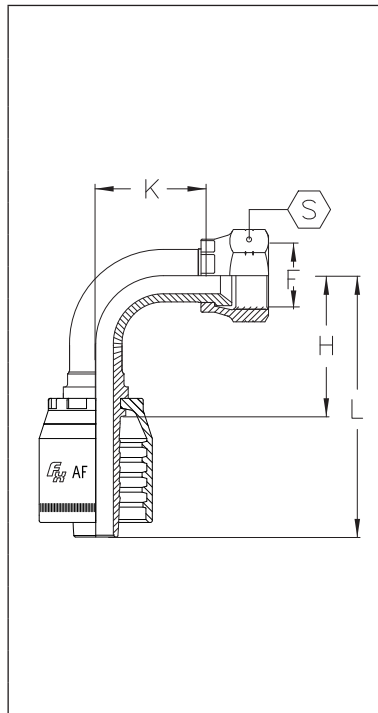

PART NUMBER	Hose Bore	F	H		L		K		S	
	INCH		[mm]	[in]	[mm]	[in]	[mm]	[in]	[mm]	[in]
AF03-04FJ90M	3/16	7/16 - 20	21.0	0.83	46.0	1.81	21	0.83	14	9/16
AF04-04FJ90M	1/4	7/16 - 20	25.5	1.00	53.5	2.11	26	1.02	14	9/16
AF04-05FJ90M	1/4	1/2 - 20	25.5	1.00	53.5	2.11	26	1.02	17	11/16
AF04-06FJ90M	1/4	9/16 - 18	25.5	1.00	53.5	2.11	27	1.06	19	3/4
AF05-05FJ90M	5/16	1/2 - 20	28.0	1.10	56.0	2.20	29	1.14	17	11/16
AF05-06FJ90M	5/16	9/16 - 18	28.0	1.10	56.0	2.20	29	1.14	19	3/4
AF06-06FJ90M	3/8	9/16 - 18	31.0	1.22	61.5	2.42	33	1.30	19	3/4
AF06-08FJ90M	3/8	3/4 - 16	31.0	1.22	61.5	2.42	33	1.30	22	7/8
AF08-08FJ90M	1/2	3/4 - 16	37.0	1.46	70.0	2.75	39	1.53	22	7/8
AF08-10FJ90M	1/2	7/8 - 14	37.0	1.46	70.0	2.75	40	1.57	27	1 1/16
AF10-10FJ90M	5/8	7/8 - 14	45.0	1.77	81.0	3.19	45	1.77	27	1 1/16
AF10-12FJ90M	5/8	1 1/16 - 12	45.0	1.77	81.0	3.19	47	1.85	32	1 1/4
AF12-10FJ90M	3/4	7/8 - 14	55.0	2.16	95.0	3.74	54	2.12	27	1 1/16
AF12-12FJ90M	3/4	1 1/16 - 12	55.0	2.16	95.0	3.74	53	2.09	32	1 1/4
AF12-14FJ90M	3/4	1 3/16 - 12	55.0	2.16	95.0	3.74	54	2.12	36	1 7/16
AF12-16FJ90M	3/4	1 5/16 - 12	55.0	2.16	95.0	3.74	56	2.20	38	1 1/2
AF16-12FJ90M	1	1 1/16 - 12	71.0	2.79	122.0	4.80	71	2.79	32	1 1/4
AF16-16FJ90M	1	1 5/16 - 12	71.0	2.79	122.0	4.80	70	2.75	38	1 1/2
AF16-20FJ90M	1	1 5/8 - 12	71.0	2.79	122.0	4.80	70	2.75	50	2

FJ90L

JIC 37° FEMALE SWIVEL - 90° ELBOW LONG DROP

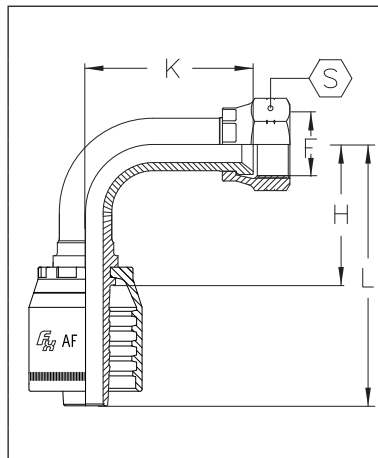

PART NUMBER	Hose Bore	F	H		L		K		S	
	INCH		[mm]	[in]	[mm]	[in]	[mm]	[in]	[mm]	[in]
AF04-04FJ90L	1/4	7/16 - 20	25.5	1.00	53.5	2.11	46	1.81	14	9/16
AF04-05FJ90L	1/4	1/2 - 20	25.5	1.00	53.5	2.11	46	1.81	17	11/16
AF04-06FJ90L	1/4	9/16 - 18	25.5	1.00	53.5	2.11	54	2.12	19	3/4
AF06-06FJ90L	3/8	9/16 - 18	31.0	1.22	61.5	2.42	54	2.12	19	3/4
AF06-08FJ90L	3/8	3/4 - 16	31.0	1.22	61.5	2.42	64	2.52	22	7/8
AF08-08FJ90L	1/2	3/4 - 16	38.0	1.50	71.0	2.79	64	2.52	22	7/8
AF08-10FJ90L	1/2	7/8 - 14	38.0	1.50	71.0	2.79	70	2.75	27	1 1/16
AF10-10FJ90L	5/8	7/8 - 14	45.0	1.77	81.0	3.19	70	2.75	27	1 1/16
AF10-12FJ90L	5/8	1 1/16 - 12	45.0	1.77	81.0	3.19	96	3.78	32	1 1/4
AF12-12FJ90L	3/4	1 1/16 - 12	55.0	2.16	95.0	3.74	96	3.78	32	1 1/4
AF16-16FJ90L	1	1 5/16 - 12	71.0	2.79	122.0	4.80	114	4.49	38	1 1/2

Reference Hose Section for Coupling Compatibility

COUPLINGS

MF ORFS MALE

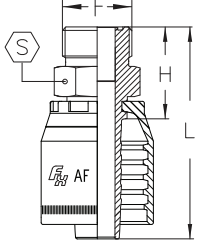

PART NUMBER	Hose Bore	F	H		L		S	
	INCH		[mm]	[in]	[mm]	[in]	[mm]	[in]
AF04-04MF	1/4	9/16 - 18	23.5	0.92	51.5	2.02	17	11/16
AF04-06MF	1/4	11/16 - 16	25.5	1.00	53.5	2.10	19	3/4
AF06-06MF	3/8	11/16 - 16	25.5	1.00	56.0	2.20	19	3/4
AF06-08MF	3/8	13/16 - 16	28.5	1.12	59.0	2.32	22	7/8
AF06-10MF	3/8	1 - 14	33.0	1.29	63.5	2.50	27	1 1/16
AF08-08MF	1/2	13/16 - 16	29.5	1.16	62.5	2.46	22	7/8
AF08-10MF	1/2	1 - 14	34.0	1.33	67.0	2.63	27	1 1/16
AF08-12MF	1/2	1 3/16 - 12	37.0	1.45	70.0	2.75	32	1 1/4
AF10-10MF	5/8	1 - 14	34.0	1.33	70.0	2.75	27	1 1/16
AF10-12MF	5/8	1 3/16 - 12	37.0	1.45	73.0	2.87	32	1 1/4
AF12-12MF	3/4	1 3/16 - 12	38.0	1.49	78.5	3.09	32	1 1/4
AF12-16MF	3/4	1 7/16 - 12	42.5	1.67	83.0	3.26	41	1 5/8
AF16-16MF	1	1 7/16 - 12	44.0	1.73	95.0	3.74	41	1 5/8

FF ORFS FEMALE SWIVEL

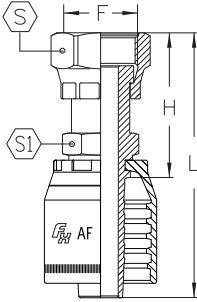

PART NUMBER	Hose Bore	F	H		L		S		S1	
	INCH		[mm]	[in]	[mm]	[in]	[mm]	[in]	[mm]	[in]
AF04-04FF	1/4	9/16 - 18	26.5	1.04	54.5	2.14	17	11/16	14	9/16
AF04-06FF	1/4	11/16 - 16	28.5	1.12	56.5	2.22	22	7/8	16	5/8
AF05-06FF	5/16	11/16 - 16	28.5	1.12	56.5	2.22	22	7/8	16	5/8
AF06-04FF	3/8	9/16 - 18	26.5	1.04	57.0	2.24	17	11/16	16	5/8
AF06-06FF	3/8	11/16 - 16	28.5	1.12	59.0	2.32	22	7/8	16	5/8
AF06-08FF	3/8	13/16 - 16	32.5	1.27	63.0	2.48	24	1	19	3/4
AF08-06FF	1/2	11/16 - 16	30.5	1.20	63.5	2.50	22	7/8	19	3/4
AF08-08FF	1/2	13/16 - 16	33.5	1.31	66.5	2.61	24	1	19	3/4
AF08-10FF	1/2	1 - 14	39.5	1.55	72.5	2.85	30	1 3/16	24	1
AF08-12FF	1/2	1 3/16 - 12	43.5	1.71	76.5	3.01	36	1 7/16	27	1 1/16
AF10-10FF	5/8	1 - 14	39.5	1.55	75.5	2.97	30	1 3/16	24	1
AF10-12FF	5/8	1 3/16 - 12	43.5	1.71	79.5	3.12	36	1 7/16	27	1 1/16
AF12-10FF	3/4	1 - 14	41.5	1.63	82.0	3.22	30	1 3/16	27	1 1/16
AF12-12FF	3/4	1 3/16 - 12	44.5	1.75	85.0	3.34	36	1 7/16	27	1 1/16
AF12-16FF	3/4	1 7/16 - 12	47.5	1.87	88.0	3.46	41	1 5/8	36	1 7/16
AF16-12FF	1	1 3/16 - 12	47.0	1.85	98.0	3.85	36	1 7/16	32	1 1/4
AF16-16FF	1	1 7/16 - 12	49.0	1.92	100.0	3.93	41	1 5/8	36	1 7/16
AF16-20FF	1	1 11/16 - 12	50.5	1.98	102.0	4.01	50	2	41	1 5/8

Reference Hose Section for Coupling Compatibility

COUPLINGS

FF45 ORFS FEMALE SWIVEL - 45° ELBOW

PART NUMBER	Hose Bore	F	H		L		K		⊕	
	INCH		[mm]	[in]	[mm]	[in]	[mm]	[in]	[mm]	[in]
AF04-04FF45	1/4	9/16 - 18	32.5	1.27	60.5	2.38	10.5	0.41	17	11/16
AF04-06FF45	1/4	11/16 - 16	34.5	1.35	62.5	2.46	12.5	0.49	22	7/8
AF05-06FF45	5/16	11/16 - 16	35.0	1.37	63.0	2.48	12.5	0.49	22	7/8
AF06-06FF45	3/8	11/16 - 16	36.0	1.41	66.5	2.61	12.5	0.49	22	7/8
AF06-08FF45	3/8	13/16 - 16	38.5	1.51	69.0	2.71	15.0	0.59	24	1
AF08-06FF45	1/2	11/16 - 16	46.5	1.83	79.5	3.12	19.5	0.76	22	7/8
AF08-08FF45	1/2	13/16 - 16	42.5	1.67	75.5	2.97	15.5	0.61	24	1
AF08-10FF45	1/2	1 - 14	45.0	1.77	78.0	3.07	17.5	0.68	30	13/16
AF08-12FF45	1/2	13/16 - 12	47.0	1.85	80.0	3.14	20.5	0.80	36	17/16
AF10-10FF45	5/8	1 - 14	49.0	1.92	85.0	3.34	18.0	0.70	30	13/16
AF10-12FF45	5/8	13/16 - 12	51.5	2.02	87.5	3.44	20.5	0.80	36	17/16
AF12-10FF45	3/4	1 - 14	64.0	2.51	104.0	4.09	25.5	1.00	30	13/16
AF12-12FF45	3/4	13/16 - 12	58.0	2.28	99.0	3.89	21.0	0.82	36	17/16
AF12-16FF45	3/4	17/16 - 12	60.5	2.38	101.0	3.97	23.5	0.92	41	15/8
AF16-16FF45	1	17/16 - 12	73.0	2.87	124.0	4.88	24.0	0.94	41	15/8

FF90S ORFS FEMALE SWIVEL - 90° ELBOW SHORT DROP

PART NUMBER	Hose Bore	F	H		L		K		⊕	
	INCH		[mm]	[in]	[mm]	[in]	[mm]	[in]	[mm]	[in]
AF04-04FF90S	1/4	9/16 - 18	27.0	1.06	55.0	2.17	21.0	0.83	17	11/16
AF04-06FF90S	1/4	11/16 - 16	27.0	1.06	55.0	2.17	24.0	0.94	22	7/8
AF05-06FF90S	5/16	11/16 - 16	29.0	1.14	57.0	2.24	25.0	0.98	22	7/8
AF06-04FF90S	3/8	9/16 - 18	30.0	1.18	60.5	2.38	22.0	0.87	17	11/16
AF06-06FF90S	3/8	11/16 - 16	31.5	1.24	62.0	2.44	24.5	0.96	22	7/8
AF06-08FF90S	3/8	13/16 - 16	34.0	1.34	61.0	2.40	30.0	1.18	24	1
AF08-08FF90S	1/2	13/16 - 16	39.0	1.54	72.0	2.83	31.0	1.22	24	1
AF08-10FF90S	1/2	1 - 14	39.0	1.54	72.0	2.83	34.0	1.34	30	13/16
AF08-12FF90S	1/2	13/16 - 12	39.0	1.54	72.0	2.83	42.0	1.65	36	17/16
AF10-10FF90S	5/8	1 - 14	45.0	1.77	81.0	3.19	35.0	1.38	30	13/16
AF10-12FF90S	5/8	13/16 - 12	45.0	1.77	81.0	3.19	42.0	1.65	36	17/16
AF12-12FF90S	3/4	13/16 - 12	55.0	2.17	95.0	3.74	45.0	1.77	36	17/16
AF12-16FF90S	3/4	17/16 - 12	55.0	2.17	95.0	3.74	49.0	1.93	41	15/8
AF16-16FF90S	1	17/16 - 12	71.0	2.79	122.0	4.80	55.0	2.17	41	15/8
AF16-20FF90S	1	111/16 - 12	71.0	2.79	122.0	4.80	58.0	2.28	50	2

Reference Hose Section for Coupling Compatibility

COUPLINGS

FF90L

ORFS FEMALE SWIVEL - 90° ELBOW LONG DROP

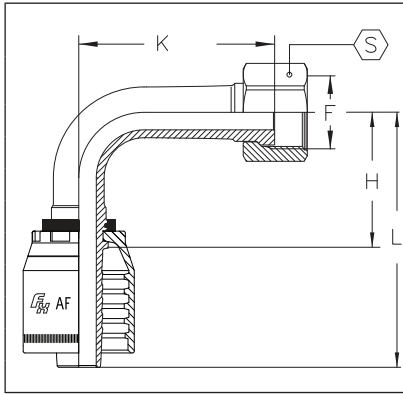

PART NUMBER	Hose Bore	F	H		L		K		S	
	INCH		[mm]	[in]	[mm]	[in]	[mm]	[in]	[mm]	[in]
AF04-04FF90L	1/4	9/16 - 18	29.0	1.14	57.0	2.24	46	1.81	17	11/16
AF04-06FF90L	1/4	11/16 - 16	27.0	1.06	55.0	2.16	54	2.12	22	7/8
AF06-06FF90L	3/8	11/16 - 16	34.0	1.33	64.5	2.53	54	2.12	22	7/8
AF06-08FF90L	3/8	13/16 - 16	34.0	1.33	64.5	2.53	64	2.51	24	1
AF08-08FF90L	1/2	13/16 - 16	39.0	1.53	72.0	2.83	64	2.51	24	1
AF08-10FF90L	1/2	1 - 14	39.0	1.53	72.0	2.83	70	2.75	30	13/16
AF10-10FF90L	5/8	1 - 14	45.0	1.77	81.0	3.18	70	2.75	30	13/16
AF12-12FF90L	3/4	13/16 - 12	55.0	2.17	95.0	3.74	96	3.77	36	17/16
AF16-16FF90L	1	17/16 - 12	71.0	2.79	122.0	4.80	114	4.48	41	15/8

FJIS

JIS FEMALE SWIVEL (TOYOTA)

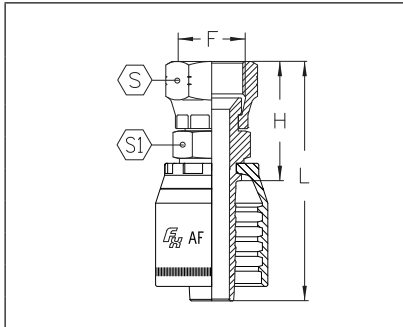

PART NUMBER	Hose Bore	F	H		L		S		S1	
	INCH		[mm]	[in]	[mm]	[in]	[mm]	[in]	[mm]	[in]
AF04-04FJIS	1/4	1/4 - 19	24	0.94	52	2.05	19	3/4	14	9/16
AF06-06FJIS	3/8	3/8 - 19	26	1.02	57	2.24	22	7/8	17	11/16
AF08-08FJIS	1/2	1/2 - 14	30	1.18	63	2.48	27	11/16	22	7/8
AF12-12FJIS	3/4	3/4 - 14	36	1.42	76	2.99	32	11/4	27	11/16
AF16-16FJIS	1	1 - 11	40	1.57	91	3.58	41	15/8	32	11/4

Reference Hose Section for Coupling Compatibility

COUPLINGS

FBSPP BSPP FEMALE SWIVEL

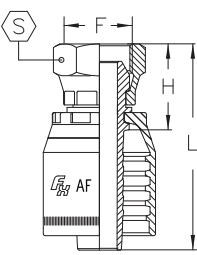
	PART NUMBER	Hose Bore	F	H		L		S	
		INCH		[mm]	[in]	[mm]	[in]	[mm]	[in]
	AF04-02FBSPP	1/4	1/8 - 28	17	0.67	45	1.77	14	9/16
	AF04-04FBSPP	1/4	1/4 - 19	19	0.75	47	1.85	19	3/4
	AF04-06FBSPP	1/4	3/8 - 19	22	0.87	50	1.97	22	7/8
	AF05-06FBSPP	5/16	3/8 - 19	22	0.87	50	1.97	22	7/8
	AF05-08FBSPP	5/16	1/2 - 14	23	0.90	51	2.01	27	1 1/16
	AF06-04FBSPP	3/8	1/4 - 19	19	0.75	49	1.93	19	3/4
	AF06-06FBSPP	3/8	3/8 - 19	21	0.83	51	2.01	22	7/8
	AF06-08FBSPP	3/8	1/2 - 14	23	0.90	54	2.12	27	1 1/16
	AF08-06FBSPP	1/2	3/8 - 19	22	0.87	56	2.20	22	7/8
	AF08-08FBSPP	1/2	1/2 - 14	23	0.90	56	2.20	27	1 1/16
	AF08-10FBSPP	1/2	5/8 - 14	24	0.94	57	2.24	30	1 3/16
	AF08-12FBSPP	1/2	3/4 - 14	27	1.06	60	2.36	32	1 1/4
	AF10-10FBSPP	5/8	5/8 - 14	23	0.90	59	2.32	30	1 3/16
	AF10-12FBSPP	5/8	3/4 - 14	27	1.06	63	2.48	32	1 1/4
	AF12-12FBSPP	3/4	3/4 - 14	27	1.06	67	2.64	32	1 1/4
	AF12-16FBSPP	3/4	1 - 11	30	1.18	70	2.75	41	1 5/8
	AF16-12FBSPP	1	3/4 - 14	28	1.10	79	3.11	32	1 1/4
	AF16-16FBSPP	1	1 - 11	30	1.18	81	3.19	41	1 5/8
	AF16-20FBSPP	1	1 1/4 - 11	35	1.38	86	3.38	50	2

FBSPP45 BSPP FEMALE SWIVEL - 45° ELBOW

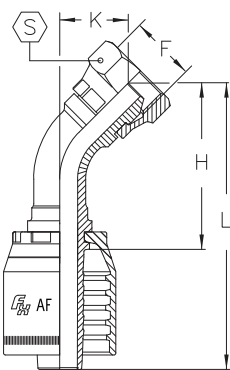
	PART NUMBER	Hose Bore	F	H		L		K		S	
		INCH		[mm]	[in]	[mm]	[in]	[mm]	[in]	[mm]	[in]
	AF04-02FBSPP45	1/4	1/8 - 28	36	1.42	64	2.52	16	0.63	14	9/16
	AF04-04FBSPP45	1/4	1/4 - 19	37	1.46	65	2.56	16	0.63	19	3/4
	AF04-06FBSPP45	1/4	3/8 - 19	40	1.57	68	2.68	19	0.75	22	7/8
	AF05-06FBSPP45	5/16	3/8 - 19	41	1.61	69	2.72	19	0.75	22	7/8
	AF06-06FBSPP45	3/8	3/8 - 19	42	1.65	73	2.87	19	0.75	22	7/8
	AF06-08FBSPP45	3/8	1/2 - 14	44	1.73	75	2.95	21	0.83	27	1 1/16
	AF08-08FBSPP45	1/2	1/2 - 14	49	1.93	82	3.23	22	0.87	27	1 1/16
	AF08-10FBSPP45	1/2	5/8 - 14	49	1.93	82	3.23	22	0.87	30	1 3/16
	AF10-10FBSPP45	5/8	5/8 - 14	54	2.12	90	3.54	24	0.94	30	1 3/16
	AF10-12FBSPP45	5/8	3/4 - 14	57	2.24	93	3.66	26	1.02	32	1 1/4
	AF12-12FBSPP45	3/4	3/4 - 14	66	2.60	106	4.17	28	1.10	32	1 1/4
	AF16-16FBSPP45	1	1 - 11	84	3.31	135	5.31	36	1.42	41	1 5/8

Reference Hose Section for Coupling Compatibility

COUPLINGS

FBSPP90 BSPP FEMALE SWIVEL - 90° ELBOW

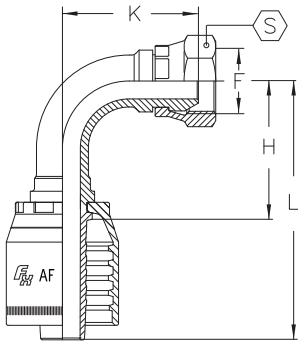

PART NUMBER	Hose Bore	F	H		L		K		S	
	INCH		[mm]	[in]	[mm]	[in]	[mm]	[in]	[mm]	[in]
AF04-02FBSPP90	1/4	1/8 - 28	26	1.02	54	2.12	28	1.10	14	9/16
AF04-04FBSPP90	1/4	1/4 - 19	26	1.02	54	2.12	28	1.10	19	3/4
AF04-06FBSPP90	1/4	3/8 - 19	26	1.02	54	2.12	32	1.26	22	7/8
AF05-06FBSPP90	5/16	3/8 - 19	28	1.10	56	2.20	34	1.34	22	7/8
AF06-06FBSPP90	3/8	3/8 - 19	31	1.22	61	2.40	35	1.38	22	7/8
AF06-08FBSPP90	3/8	1/2 - 14	31	1.22	61	2.40	38	1.50	27	1 1/16
AF08-08FBSPP90	1/2	1/2 - 14	37	1.46	70	2.75	42	1.65	27	1 1/16
AF08-10FBSPP90	1/2	5/8 - 14	37	1.46	70	2.75	43	1.69	30	1 3/16
AF10-10FBSPP90	5/8	5/8 - 14	45	1.77	80	3.15	46	1.81	30	1 3/16
AF10-12FBSPP90	5/8	3/4 - 14	45	1.77	80	3.15	50	1.97	32	1 1/4
AF12-12FBSPP90	3/4	3/4 - 14	54	2.12	95	3.74	56	2.20	32	1 1/4
AF12-16FBSPP90	3/4	1 - 11	54	2.12	95	3.74	59	2.32	41	1 5/8
AF16-12FBSPP90	1	3/4 - 14	70	2.76	121	4.76	75	2.95	32	1 1/4
AF16-16FBSPP90	1	1 - 11	70	2.76	121	4.76	72	2.83	41	1 5/8

FML FEMALE METRIC LIGHT SWIVEL (24° SEAT) - DKOL

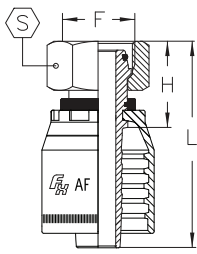

PART NUMBER	Hose Bore	F	Tube	H		L		S	
	INCH			[mm]	[in]	[mm]	[in]	[mm]	[in]
AF04-12FML	1/4	M12 x 1.5	L6	23	0.90	51	2.01	17	11/16
AF04-14FML	1/4	M14 x 1.5	L8	22	0.87	50	1.97	17	11/16
AF04-16FML	1/4	M16 x 1.5	L10	24	0.94	52	2.05	19	3/4
AF04-18FML	1/4	M18 x 1.5	L12	24	0.94	52	2.05	22	7/8
AF05-16FML	5/16	M16 x 1.5	L10	24	0.94	52	2.05	19	3/4
AF05-18FML	5/16	M18 x 1.5	L12	24	0.94	52	2.05	22	7/8
AF06-16FML	3/8	M16 x 1.5	L10	23	0.90	54	2.12	19	3/4
AF06-18FML	3/8	M18 x 1.5	L12	24	0.94	54	2.12	22	7/8
AF06-22FML	3/8	M22 x 1.5	L15	24	0.94	54	2.12	27	1 1/16
AF08-22FML	1/2	M22 x 1.5	L15	24	0.94	57	2.24	27	1 1/16
AF08-26FML	1/2	M26 x 1.5	L18	26	1.02	59	2.32	32	1 1/4
AF10-26FML	5/8	M26 x 1.5	L18	27	1.06	62	2.44	32	1 1/4
AF10-30FML	5/8	M30 x 2.0	L22	28	1.10	64	2.52	36	1 7/16
AF12-26FML	3/4	M26 x 1.5	L18	34	1.34	75	2.95	32	1 1/4
AF12-30FML	3/4	M30 x 2.0	L22	31	1.22	71	2.79	36	1 7/16
AF16-36FML	1	M36 x 2.0	L28	32	1.26	83	3.27	41	1 5/8

Reference Hose Section for Coupling Compatibility

COUPLINGS

MP NPT MALE

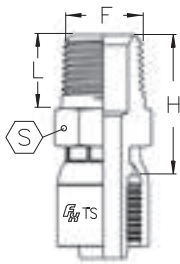

PART NUMBER	Hose Bore	F	H		L		S	
	INCH		[mm]	[in]	[mm]	[in]	[mm]	[in]
TS03-02MP*	3/16	1/8 - 27	23.4	0.92	9.5	0.37	14	9/16
TS04-02MP*	1/4	1/8 - 27	23.4	0.92	9.5	0.37	14	9/16
TS04-04MP*	1/4	1/4 - 18	29.3	1.15	14.4	0.57	14	9/16
TS04-06MP*	1/4	3/8 - 18	29.5	1.16	14.6	0.57	19	3/4
TS05-04MP*	5/16	1/4 - 18	29.3	1.15	14.4	0.57	15	5/8
TS06-04MP*	3/8	1/4 - 18	29.4	1.16	14.4	0.57	17	11/16
TS06-06MP*	3/8	3/8 - 18	29.6	1.17	14.6	0.57	19	3/4
TS08-06MP*	1/2	3/8 - 18	31.1	1.22	14.6	0.57	19	3/4
TS08-08MP*	1/2	1/2 - 14	36.5	1.44	19.0	0.75	22	7/8
TS10-08MP*	5/8	1/2 - 14	36.5	1.44	19.0	0.75	24	1
TS12-12MP*	3/4	3/4 - 14	39.8	1.57	19.3	0.76	28	1 1/8
TS16-16MP*	1	1 - 11 1/2	45.5	1.79	24.0	0.94	35	1 7/16

* Add the appropriate suffix for material - BR (brass) - SS (316) stainless steel - CS (carbon steel).

FJ JIC 37° FEMALE SWIVEL

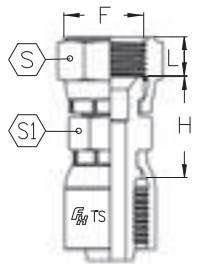

PART NUMBER	Hose Bore	F	H		L		S		S1	
	INCH		[mm]	[in]	[mm]	[in]	[mm]	[in]	[mm]	[in]
TS03-03FJ*	3/16	3/8 - 24					15	5/8	12	1/2
TS03-04FJ*	3/16	7/16 - 20	21.9	0.86	9.0	0.35	15	5/8	14	9/16
TS04-04FJ*	1/4	7/16 - 20	21.9	0.86	9.0	0.35	15	5/8	14	9/16
TS04-05FJ*	1/4	1/2 - 20	22.9	0.90	9.5	0.37	17	11/16	14	9/16
TS04-06FJ*	1/4	9/16 - 18	23.9	0.94	9.5	0.37	19	3/4	14	9/16
TS05-06FJ*	5/16	9/16 - 18	23.9	0.94	9.5	0.37	19	3/4	14	9/16
TS06-06FJ*	3/8	9/16 - 18	24.0	0.94	9.5	0.37	19	3/4	17	11/16
TS06-08FJ*	3/8	3/4 - 16	25.5	1.00	10.5	0.41	25	1	19	3/4
TS08-08FJ*	1/2	3/4 - 16	27.0	1.06	10.5	0.41	25	1	19	3/4
TS08-10FJ*	1/2	7/8 - 14	29.0	1.14	12.5	0.49	25	1	22	7/8
TS12-12FJ*	3/4	1 1/16 - 12	33.0	1.30	14.5	0.57	32	1 1/4	27	1 1/16
TS16-16FJ*	1	1 5/16 - 12	36.0	1.42	15.1	0.59	35	1 3/8	38	1 1/2

* Add the appropriate suffix for material - BR (brass) - SS (316) stainless steel - CS (carbon steel).

Reference Hose Section for Coupling Compatibility

COUPLINGS

MA SAE 45° MALE

	PART NUMBER	Hose Bore	F	H	
		INCH		[mm]	[in]
	Z06-06MA*	5/16	5/8 - 18	48	1.89
	Z08-08MA*	13/32	3/4 - 16	51	2.01
	Z10-10MA*	1/2	7/8 - 14	59	2.32
	Z12-12MA*	5/8	1 1/16 - 14	64	2.52

*ZR series are compatible with standard barrier hose. For reduced barrier change from Z to ZR part numbers.

FA SAE 45° FEMALE SWIVEL

	PART NUMBER	Hose Bore	F	H	
		INCH		[mm]	[in]
	Z06-06FA*	5/16	5/8 - 18	35	1.38
	Z06-08FA*	5/16	3/4 - 16	30	1.18
	Z08-08FA*	13/32	3/4 - 16	30	1.18
	Z10-10FA*	1/2	7/8 - 14	38	1.50
Z12-10FA*	5/8	7/8 - 14	44	1.73	
Z12-12FA*	5/8	1 1/16 - 14	44	1.73	

*ZR series are compatible with standard barrier hose. For reduced barrier change from Z to ZR part numbers.

FA45 SAE 45° FEMALE SWIVEL - 45° ELBOW

	PART NUMBER	Hose Bore	F	H		K	
		INCH		[mm]	[in]	[mm]	[in]
	Z06-06FA45*	5/16	5/8 - 18	21	0.83	14	.55
	Z08-08FA45*	13/32	3/4 - 16	24	0.94	16	.63
	Z10-10FA45*	1/2	7/8 - 14	32	1.26	22	.87
	Z12-10FA45*	5/8	7/8 - 14	38	1.50	25	.98
Z12-12FA45*	5/8	1 1/16 - 14	38	1.50	25	.98	

*ZR series are compatible with standard barrier hose. For reduced barrier change from Z to ZR part numbers.

Reference Hose Section for Coupling Compatibility

COUPLINGS

FA90 SAE 45° FEMALE SWIVEL - 90° ELBOW

	PART NUMBER	Hose Bore	F	H		K	
		INCH		[mm]	[in]	[mm]	[in]
	Z06-06FA90*	5/16	5/8 - 18	27	1.06	27	1.06
Z08-08FA90*	13/32	3/4 - 16	32	1.26	32	1.26	
Z10-10FA90*	1/2	7/8 - 14	38	1.50	38	1.50	
Z12-10FA90*	5/8	7/8 - 14	44	1.73	38	1.50	
Z12-12FA90*	5/8	1 1/16 - 14	44	1.73	38	1.50	

*ZR series are compatible with standard barrier hose. For reduced barrier change from Z to ZR part numbers.

MRNS SAE FLARELESS MALE ASSEMBLY

	PART NUMBER	Hose Bore	F	TUBE O.D.		H	
		INCH		[mm]	[in]	[mm]	[in]
	Z06-06MRNS*	5/16	5/8 - 18	9.53	.375	30	1.17
Z08-08MRNS*	13/32	3/4 - 16	12.70	.500	35	1.36	
Z08-10MRNS*	13/32	7/8 - 14	15.88	.625	38	1.48	
Z10-08MRNS*	1/2	3/4 - 16	12.70	.500	38	1.48	
Z10-10MRNS*	1/2	7/8 - 14	15.88	.625	38	1.48	
Z12-10MRNS*	5/8	7/8 - 14	15.88	.625	43	1.71	
Z12-12MRNS*	5/8	1 1/16 - 14	19.05	.750	46	1.83	

*ZR series are compatible with standard barrier hose. For reduced barrier change from Z to ZR part numbers.

BTF BUMPED TUBE O-RING FEMALE SWIVEL

	PART NUMBER	Hose Bore	F	H	
		INCH		[mm]	[in]
	Z06-06BTF*	5/16	5/8 - 18	35	1.38
Z06-08BTF*	5/16	3/4 - 16	38	1.50	
Z08-08BTF*	13/32	3/4 - 16	38	1.50	
Z10-08BTF*	1/2	7/8 - 14	43	1.69	
Z10-10BTF*	1/2	1 1/16 - 14	43	1.69	
Z12-10BTF*	5/8	7/8 - 14	46	1.81	
Z12-12BTF*	5/8	1 1/16 - 14	46	1.81	

*ZR series are compatible with standard barrier hose. For reduced barrier change from Z to ZR part numbers.

Reference Hose Section for Coupling Compatibility

www.**FLEXTAL**.com

COUPLINGS

BTF-P BUMPED TUBE O-RING FEMALE SWIVEL (R134a SERVICE PORT)

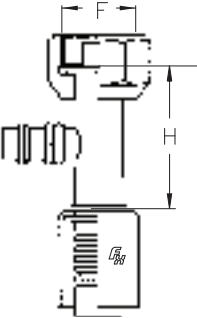
	PART NUMBER	Hose Bore	F	H	
		INCH		[mm]	[in]
	Z06-06BTF-P*	5/16	5/8 - 18	48	1.89
Z08-08BTF-P*	13/32	3/4 - 16	48	1.89	
Z10-10BTF-P*	1/2	7/8 - 14	54	2.13	
Z12-12BTF-P*	5/8	1 1/16 - 14	57	2.24	

*ZR series are compatible with standard barrier hose. For reduced barrier change from Z to ZR part numbers.

BTF45 BUMPED TUBE O-RING FEMALE SWIVEL - 45° ELBOW

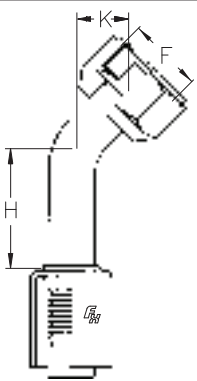
	PART NUMBER	Hose Bore	F	H		K	
		INCH		[mm]	[in]	[mm]	[in]
	Z06-06BTF45*	5/16	5/8 - 18	21	.83	14	.55
Z08-08BTF45*	13/32	3/4 - 16	24	.94	16	.63	
Z10-10BTF45*	1/2	7/8 - 14	32	1.26	22	.87	
Z12-10BTF45*	5/8	7/8 - 14	38	1.50	24	.94	
Z12-12BTF45*	5/8	1 1/16 - 14	38	1.50	24	.94	

*ZR series are compatible with standard barrier hose. For reduced barrier change from Z to ZR part numbers.

BTF45-P BUMPED TUBE O-RING FEMALE SWIVEL - 45° ELBOW (R134a SERVICE PORT)

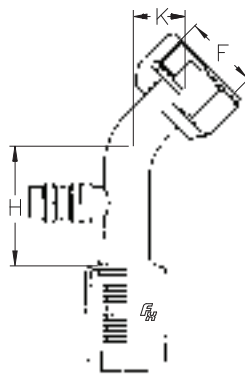
	PART NUMBER	Hose Bore	F	H		K	
		INCH		[mm]	[in]	[mm]	[in]
	Z06-06BTF45-P*	5/16	5/8 - 18	41	1.61	14	.55
Z08-08BTF45-P*	13/32	3/4 - 16	41	1.61	16	.63	
Z10-10BTF45-P*	1/2	7/8 - 14	44	1.73	22	.87	
Z12-10BTF45-P*	5/8	7/8 - 14	48	1.89	24	.94	
Z12-12BTF45-P*	5/8	1 1/16 - 14	48	1.89	24	.94	

*ZR series are compatible with standard barrier hose. For reduced barrier change from Z to ZR part numbers.

COUPLINGS

BTF90 BUMPED TUBE O-RING FEMALE SWIVEL - 90° ELBOW

	PART NUMBER	Hose Bore	F	H		K	
		INCH		[mm]	[in]	[mm]	[in]
	Z06-06BTF90*	5/16	5/8 - 18	27	1.06	28	1.10
	Z06-08BTF90*	5/16	3/4 - 16	32	1.26	33	1.30
	Z08-06BTF90*	13/32	5/8 - 18	32	1.26	33	1.30
	Z08-08BTF90*	13/32	3/4 - 16	32	1.26	33	1.30
	Z10-10BTF90*	1/2	7/8 - 14	38	1.50	38	1.50
	Z12-10BTF90*	5/8	7/8 - 14	45	1.77	45	1.77
Z12-12BTF90*	5/8	1 1/16 - 14	45	1.77	45	1.77	

*ZR series are compatible with standard barrier hose. For reduced barrier change from Z to ZR part numbers.

BTF90-P BUMPED TUBE O-RING FEMALE SWIVEL - 90° ELBOW (R134a SERVICE PORT)

	PART NUMBER	Hose Bore	F	H		K	
		INCH		[mm]	[in]	[mm]	[in]
	Z06-06BTF90-P*	5/16	5/8 - 18	54	2.13	28	1.10
	Z08-08BTF90-P*	13/32	3/4 - 16	54	2.13	33	1.30
	Z10-10BTF90-P*	1/2	7/8 - 14	60	2.36	38	1.50
	Z12-10BTF90-P*	5/8	7/8 - 14	68	2.68	44	1.73
	Z12-12BTF90-P*	5/8	1 1/16 - 14	68	2.68	44	1.73

*ZR series are compatible with standard barrier hose. For reduced barrier change from Z to ZR part numbers.

BTM BUMPED TUBE O-RING MALE SWIVEL

	PART NUMBER	Hose Bore	F	H	
		INCH		[mm]	[in]
	Z06-06BTM*	5/16	5/8 - 18	43	1.69
	Z08-08BTM*	13/32	3/4 - 18	45	1.77
	Z10-10BTM*	1/2	7/8 - 18	48	1.89
	Z10-12BTM*	1/2	1 1/16 - 16	60	2.36
	Z12-10BTM*	5/8	7/8 - 18	60	2.36
	Z12-12BTM*	5/8	1 1/16 - 16	60	2.36

*ZR series are compatible with standard barrier hose. For reduced barrier change from Z to ZR part numbers.

Reference Hose Section for Coupling Compatibility

COUPLINGS

BTM45 BUMPED TUBE O-RING MALE SWIVEL - 45° ELBOW

PART NUMBER	Hose Bore	F	H		K	
	INCH		[mm]	[in]	[mm]	[in]
Z06-06BTM45*	5/16	5/8 - 18	21	.83	22	.87
Z08-08BTM45*	13/32	3/4 - 18	24	.95	25	.98
Z10-10BTM45*	5/8	7/8 - 18	32	1.26	27	1.06
Z12-12BTM45*	5/8	1 1/16 - 16	38	1.50	30	1.18

*ZR series are compatible with standard barrier hose. For reduced barrier change from Z to ZR part numbers.

BTM90 BUMPED TUBE O-RING MALE SWIVEL - 90° ELBOW

PART NUMBER	Hose Bore	F	H		K	
	INCH		[mm]	[in]	[mm]	[in]
Z06-06BTM90*	5/16	5/8 - 18	27	1.06	41	1.61
Z08-08BTM90*	13/32	3/4 - 18	32	1.26	48	1.89
Z10-10BTM90*	1/2	7/8 - 18	38	1.50	54	2.13
Z12-10BTM90*	5/8	7/8 - 18	45	1.77	57	2.24
Z12-12BTM90*	5/8	1 1/16 - 16	45	1.77	57	2.24

*ZR series are compatible with standard barrier hose. For reduced barrier change from Z to ZR part numbers.

BTM90-P BUMPED TUBE O-RING MALE SWIVEL - 90° ELBOW (R134a SERVICE PORT)

PART NUMBER	Hose Bore	F	H		K	
	INCH		[mm]	[in]	[mm]	[in]
Z06-06BTM90-P*	5/16	5/8 - 18	54	2.13	41	1.16
Z08-08BTM90-P*	5/16	3/4 - 18	54	2.13	48	1.89
Z10-10BTM90-P*	13/32	7/8 - 18	60	2.36	54	2.13
Z12-12BTM90-P*	13/32	1 1/16 - 16	68	2.68	55	2.17

*ZR series are compatible with standard barrier hose. For reduced barrier change from Z to ZR part numbers.

Reference Hose Section for Coupling Compatibility

COUPLINGS

IOM INSERT O-RING MALE

	PART NUMBER	Hose Bore	F	H	
		INCH		[mm]	[in]
	Z06-06IOM*	5/16	5/8 - 18	37	1.46
	Z08-08IOM*	13/32	3/4 - 16	41	1.61
	Z10-10IOM*	1/2	7/8 - 14	54	2.13
	Z12-10IOM*	5/8	7/8 - 14	43	1.69
	Z12-12IOM*	5/8	1 1/16 - 14	60	2.36

*ZR series are compatible with standard barrier hose. For reduced barrier change from Z to ZR part numbers.

IOM90 INSERT O-RING MALE - 90° ELBOW

	PART NUMBER	Hose Bore	F	H		K	
		INCH		[mm]	[in]	[mm]	[in]
	Z06-06IOM90*	5/16	5/8 - 18	27	1.06	38	1.50
	Z08-08IOM90*	13/32	3/4 - 16	32	1.26	44	1.73
	Z10-10IOM90*	1/2	7/8 - 14	38	1.50	51	2.00
	Z12-12IOM90*	5/8	1 1/16 - 14	60	2.36	64	2.52

*ZR series are compatible with standard barrier hose. For reduced barrier change from Z to ZR part numbers.

HM HOSE MENDER

	PART NUMBER	Hose Bore	Hose Bore	H	
		INCH	INCH	[mm]	[in]
	Z06-06HM*	5/16	5/16	38	1.50
	Z06-08HM*	5/16	13/32	38	1.50
	Z08-08HM*	13/32	13/32	38	1.50
	Z08-10HM*	13/32	1/2	41	1.61
	Z10-10HM*	1/2	1/2	41	1.61
	Z10-12HM*	1/2	5/8	44	1.73
	Z12-12HM*	5/8	5/8	44	1.73

*ZR series are compatible with standard barrier hose. For reduced barrier change from Z to ZR part numbers.

Reference Hose Section for Coupling Compatibility

COUPLINGS

HM-P HOSE MENDER (R134a SERVICE PORT)

	PART NUMBER	Hose Bore	Hose Bore	F	
		INCH	INCH	[mm]	[in]
	Z06-06HM-P*	5/16	5/16	38	1.50
	Z08-08HM-P*	13/32	13/32	38	1.50
	Z10-10HM-P*	1/2	1/2	41	1.61
	Z12-12HM-P*	5/8	5/8	44	1.73

*ZR series are compatible with standard barrier hose. For reduced barrier change from Z to ZR part numbers.

BS BRAZE SOCKET

	PART NUMBER	Hose Bore	F	H	
		INCH		[mm]	[in]
	Z06-06BS*	5/16	3/8	15	.59
	Z08-08BS*	13/32	1/2	15	.59
	Z10-10BS*	1/2	5/8	15	.59
	Z12-12BS*	5/8	3/4	15	.59

*ZR series are compatible with standard barrier hose. For reduced barrier change from Z to ZR part numbers.

ACF AIR CONDITIONING FERRULE

	PART NUMBER	Hose Bore	F	H	
		INCH		[mm]	[in]
	Z06ACF*	5/16		36	1.42
	Z08ACF*	13/32		36	1.42
	Z10ACF*	1/2		36	1.42
	Z12ACF*	5/8		36	1.42

*ZR series are compatible with standard barrier hose. For reduced barrier change from Z to ZR part numbers.

ACO AIR CONDITIONING O-RINGS

	PART NUMBER	TUBE O.D.	I.D.		WIDTH	
			[mm]	[in]	[mm]	[in]
	Z06ACO*	3/8	7.65	.30	1.78	
	Z08ACO*	1/2	10.82	.43	1.78	
	Z10ACO*	5/8	14.00	.55	1.78	
	Z12ACO*	3/4	17.17	.68	1.78	

*ZR series are compatible with standard barrier hose. For reduced barrier change from Z to ZR part numbers.

COUPLINGS

MP NPT MALE

	PART NUMBER	Hose Bore	T
		INCH	
	J04-02MP	1/4	1/8 - 27
	J04-04MP	1/4	1/4 - 18
	J04-06MP	1/4	3/8 - 18
	J05-02MP	5/16	1/8 - 27
	J05-04MP	5/16	1/4 - 18
	J06-02MP	3/8	1/8 - 27
	J06-04MP	3/8	1/4 - 18
	J06-06MP	3/8	3/8 - 18
	J06-08MP	3/8	1/2 - 14
	J08-06MP	1/2	3/8 - 18
	J08-08MP	1/2	1/2 - 14
	J08-12MP	1/2	3/4 - 14
	J10-08MP	5/8	1/2 - 14
	J10-12MP	5/8	3/4 - 14
	J12-08MP	3/4	1/2 - 14
	J12-12MP	3/4	3/4 - 14
	J16-16MP	1	1 - 11 1/2

MP90 NPT MALE - 90° ELBOW

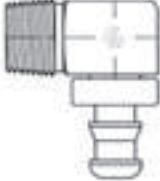
	PART NUMBER	Hose Bore	T
		INCH	
	J05-02MP90	5/16	1/8 - 27
	J05-04MP90	5/16	1/4 - 18
	J06-02MP90	3/8	1/8 - 27
	J06-04MP90	3/8	1/4 - 18

MPX NPT MALE LIVE SWIVEL

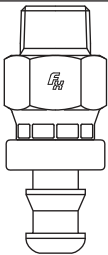
	PART NUMBER	Hose Bore	T
		iii	
	J04-04MPX	1/4	1/4 - 18
	J06-06MPX	3/8	3/8 - 18
	J08-08MPX	1/2	1/2 - 14
	J12-12MPX	3/4	3/4 - 14

Reference Hose Section for Coupling Compatibility

COUPLINGS

FP NPT FEMALE

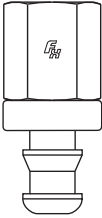
	PART NUMBER	Hose Bore	T
		INCH	
	J04-02FP	1/4	1/4 - 18
	J04-04FP	1/4	1/4 - 18
	J06-04FP	3/8	1/4 - 18
	J06-06FP	3/8	3/8 - 18
J08-08FP	1/2	1/2 - 14	

FPXT NPT FEMALE SWIVEL

	PART NUMBER	Hose Bore	T
		INCH	
	J04-04FPXT	1/4	1/4 - 18
	J06-06FPXT	3/8	3/8 - 18
	J08-08FPXT	1/2	1/2 - 14

FJ JIC 37° FEMALE SWIVEL

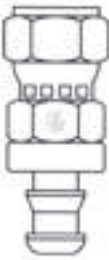
	PART NUMBER	Hose Bore	T
		INCH	
	J04-04FJ	1/4	7/16 - 20
	J04-05FJ	1/4	1/2 - 20
	J05-05FJ	5/16	1/2 - 20
	J06-05FJ	3/8	1/2 - 20
	J06-06FJ	3/8	9/16 - 18
	J06-08FJ	3/8	3/4 - 16
	J08-08FJ	1/2	3/4 - 16
	J08-10FJ	1/2	7/8 - 14
	J10-10FJ	5/8	7/8 - 14
	J12-10FJ	3/4	7/8 - 14
	J12-12FJ	3/4	1 1/16 - 12
	J16-16FJ	1	1 9/16 - 12

Reference Hose Section for Coupling Compatibility

COUPLINGS

MJ JIC 37° MALE

	PART NUMBER	Hose Bore	T
		INCH	
	J04-04MJ	1/4	7/16 - 20
	J04-05MJ	1/4	1/2 - 20
	J05-05MJ	5/16	1/2 - 20
J06-06MJ	3/8	9/16 - 18	

MA SAE 45° MALE

	PART NUMBER	Hose Bore	T
		INCH	
	J06-06MA	3/8	5/8 - 18

FA SAE 45° FEMALE SWIVEL

	PART NUMBER	Hose Bore	T
		INCH	
	J06-06FA	3/8	5/8 - 18
	J12-12FA	3/4	1 1/16 - 14

MIX SAE INVERTED FLARE MALE SWIVEL

	PART NUMBER	Hose Bore	T
		INCH	
	J04-03MIX	1/4	3/8 - 24
	J04-04MIX	1/4	7/16 - 24
	J04-05MIX	1/4	1/2 - 20
	J05-04MIX	5/16	7/16 - 24
	J05-05MIX	5/16	1/2 - 20
	J05-06MIX	5/16	5/8 - 18
	J06-05MIX	3/8	1/2 - 20
J06-06MIX	3/8	5/8 - 18	
J08-08MIX	1/2	3/4 - 18	

Reference Hose Section for Coupling Compatibility

COUPLINGS

FIX SAE INVERTED FLARE FEMALE RIGID

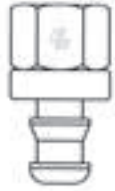
	PART NUMBER	Hose Bore	T
		INCH	
	J04-03FIX	1/4	3/8 - 24
	J04-04FIX	1/4	7/16 - 24
	J04-05FIX	1/4	1/2 - 20
	J05-05FIX	5/16	1/2 - 20
	J06-05FIX	3/8	1/2 - 20
	J06-06FIX	3/8	5/8 - 18
	J08-08FIX	1/2	3/4 - 18

FML FEMALE METRIC LIGHT SWIVEL (24° SEAT) - DKOL

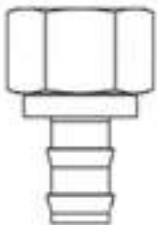
	PART NUMBER	Hose Bore	T
		INCH	
	J04-12FML	1/4	M12 x 1.5
	J04-14FML	1/4	M14 x 1.5
	J04-16FML	1/4	M16 x 1.5
	J06-16FML	3/8	M16 x 1.5
	J06-18FML	3/8	M18 x 1.5
	J08-18FML	1/2	M18 x 1.5
	J08-22FML	1/2	M22 x 1.5
	J10-22FML	1/2	M22 x 1.5
	J10-26FML	5/8	M26 x 1.5
	J12-30FML	3/4	M30 x 2.0
	J16-36FML	1	M36 x 2.0

FML45 FEMALE METRIC LIGHT SWIVEL - 45° ELBOW (24° SEAT) - DKOL

	PART NUMBER	Hose Bore	T
		INCH	
	J04-12FML45	1/4	M12 x 1.5
	J04-14FML45	1/4	M14 x 1.5
	J04-16FML45	1/4	M16 x 1.5
	J08-18FML45	1/2	M18 x 1.5
	J08-22FML45	1/2	M22 x 1.5
	J10-26FML45	5/8	M26 x 1.5
	J12-30FML45	3/4	M30 x 2.0
	J16-36FML45	1	M36 x 2.0

Reference Hose Section for Coupling Compatibility

COUPLINGS

FML90 FEMALE METRIC LIGHT SWIVEL - 90° ELBOW (24° SEAT) - DKOL

	PART NUMBER	Hose Bore	T
		INCH	
	J04-12FML90	1/4	M12 x 1.5
	J04-14FML90	1/4	M14 x 1.5
	J04-16FML90	1/4	M16 x 1.5
	J06-16FML90	3/8	M16 x 1.5
	J06-18FML90	3/8	M18 x 1.5
	J08-22FML90	1/2	M22 x 1.5
	J10-26FML90	5/8	M26 x 1.5
J12-30FML90	3/4	M30 x 2.0	
J16-36FML90	1	M36 x 2.0	

HM HOSE MENDER

	PART NUMBER	Hose Bore	
		INCH	
	J04-04HM	1/4	
	J05-05HM	5/16	
	J06-06HM	3/8	
	J08-08HM	1/2	
	J10-10HM	5/8	
J12-12HM	3/4		

SP IMPERIAL STANDPIPE

	PART NUMBER	Hose Bore	TUBE O.D.
		INCH	
	J04-03SP	1/4	3/16
	J04-04SP	1/4	1/4
	J04-05SP	1/4	5/16
	J06-06SP	3/8	3/8
J08-08SP	1/2	1/2	

Reference Hose Section for Coupling Compatibility

COUPLINGS

MP

NPT MALE

	PART NUMBER	Hose Bore	F	H		L		S		S1	
		INCH		[mm]	[in]	[mm]	[in]	[mm]	[in]	[mm]	[in]
	1R04-04MP	1/4	1/4 - 18	30.0	1.18	54.6	2.15	14	9/16	19	3/4
1R06-06MP	3/8	3/8 - 18	31.7	1.25	58.7	2.31	17	11/16	22	7/8	
1R08-08MP	1/2	1/2 - 14	38.3	1.51	69.9	2.75	22	7/8	27	1 1/16	

FJ

JIC 37° FEMALE SWIVEL

	PART NUMBER	Hose Bore	F	H		L		S		S1	
		INCH		[mm]	[in]	[mm]	[in]	[mm]	[in]	[mm]	[in]
	1R04-04FJ	1/4	7/16 - 20	30.7	1.21	55.4	2.18	14	9/16	19	3/4
1R06-06FJ	3/8	9/16 - 18	35.3	1.39	62.2	2.45	17	11/16	22	7/8	
1R08-08FJ	1/2	3/4 - 16	39.9	1.57	71.4	2.81	22	7/8	27	1 1/16	

COUPLINGS

MP NPT MALE

	PART NUMBER	Hose Bore	F	H		L		S		Si	
		INCH		[mm]	[in]	[mm]	[in]	[mm]	[in]	[mm]	[in]
	2R04-04MP	1/4	1/4 - 18	34.0	1.34	65.0	2.56	14	9/16	20.6	13/16
	2R06-06MP	3/8	3/8 - 18	33.3	1.31	70.6	2.78	17	11/16	24.0	1
	2R08-06MP	1/2	3/8 - 18	34.8	1.37	74.4	2.93	22	7/8	28.0	1 1/8
	2R08-08MP	1/2	1/2 - 14	39.6	1.56	79.2	3.12	22	7/8	28.0	1 1/8
	2R12-12MP	3/4	3/4 - 14	44.4	1.75	92.7	3.65	27	1 1/16	38.0	1 1/2
	2R16-16MP	1	1 - 11 1/2	57.9	2.28	110.2	4.34	34	1 3/8	43.0	1 3/4

FJ JIC 37° FEMALE SWIVEL

	PART NUMBER	Hose Bore	F	H		L		S		Si	
		INCH		[mm]	[in]	[mm]	[in]	[mm]	[in]	[mm]	[in]
	2R04-04FJ	1/4	7/16 - 20	34.8	1.37	66.5	2.62	14	9/16	20.6	13/16
	2R06-06FJ	3/8	9/16 - 18	38.1	1.50	74.9	2.95	17	11/16	24.0	1
	2R06-08FJ	3/8	3/4 - 16	41.4	1.63	74.9	2.95	22	7/8	24.0	1
	2R08-08FJ	1/2	3/4 - 16	42.4	1.67	82.0	3.23	22	7/8	28.0	1 1/8
	2R08-10FJ	1/2	7/8 - 14	44.9	1.77	84.6	3.33	25	1	32.0	1 1/4
	2R12-12FJ	3/4	1 1/16 - 12	50.8	2.00	98.8	3.89	32	1 1/4	38.0	1 1/2
	2R16-16FJ	1	1 5/8 - 12	61.7	2.43	113.0	4.45	38	1 1/2	43.0	1 3/4

COUPLINGS

MP

NPT MALE

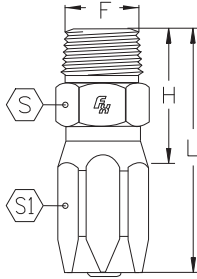

PART NUMBER	Hose Bore	F	H		L		S		S1	
	INCH		[mm]	[in]	[mm]	[in]	[mm]	[in]	[mm]	[in]
5R04-02MP	3/16	1/8 - 27	23.4	0.92	42.4	1.67	14.0	9/16	15.0	5/8
5R04-04MP	3/16	1/4 - 18	27.9	1.10	47.0	1.85	14.0	9/16	15.0	5/8
5R05-04MP	1/4	1/4 - 18	30.0	1.18	49.8	1.96	14.0	9/16	17.0	11/16
5R06-04MP	5/16	1/4 - 18	31.2	1.23	55.1	2.17	14.0	9/16	20.6	13/16
5R06-06MP	5/16	3/8 - 18	32.0	1.26	55.9	2.20	17.0	11/16	20.6	13/16
5R08-06MP	13/32	3/8 - 18	33.5	1.32	63.0	2.48	17.0	11/16	24.0	1
5R08-08MP	13/32	1/2 - 14	39.6	1.56	68.8	2.71	22.0	7/8	24.0	1
5R10-08MP	1/2	1/2 - 14	40.4	1.59	72.4	2.85	22.0	7/8	28.0	1 1/8
5R12-12MP	5/8	3/4 - 14	42.4	1.67	81.3	3.20	27.0	1 1/16	32.0	1 1/4
5R16-16MP	7/8	1 - 11 1/2	43.4	1.71	75.7	2.98	34.0	1 3/8	35.0	1 7/16

MJ

JIC 37° MALE

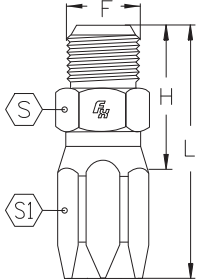

PART NUMBER	Hose Bore	F	H		L		S		S1	
	INCH		[mm]	[in]	[mm]	[in]	[mm]	[in]	[mm]	[in]
5R04-04MJ	3/16	7/16 - 20	27.7	1.09	46.7	1.84	12.0	1/2	16.0	5/8
5R05-05MJ	1/4	1/2 - 20	29.7	1.17	49.5	1.95	14.0	9/16	17.0	11/16
5R06-06MJ	5/16	9/16 - 18	30.7	1.21	53.8	2.12	16.0	5/8	20.6	13/16
5R08-08MJ	13/32	3/4 - 16	33.3	1.31	65.0	2.56	20.6	13/16	24.0	1

FJ

JIC 37° FEMALE SWIVEL

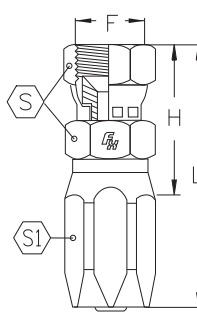

PART NUMBER	Hose Bore	F	H		L		S		S1	
	INCH		[mm]	[in]	[mm]	[in]	[mm]	[in]	[mm]	[in]
5R04-04FJ	3/16	7/16 - 20	30.0	1.18	49.0	1.93	15.0	5/8	14.0	9/16
5R05-05FJ	1/4	1/2 - 20	32.8	1.29	52.6	2.07	16.0	5/8	17.0	11/16
5R06-06FJ	5/16	9/16 - 18	35.6	1.40	58.7	2.31	17.0	11/16	20.6	13/16
5R08-08FJ	13/32	3/4 - 16	39.9	1.57	72.1	2.84	22.0	7/8	24.0	1
5R10-10FJ	1/2	7/8 - 14	42.4	1.67	77.7	3.06	24.0	1	28.0	1 1/8
5R12-12FJ	5/8	1 1/16 - 12	48.8	1.92	88.9	3.50	32.0	1 1/4	32.0	1 1/4
5R16-16FJ	7/8	1 5/16 - 12	48.8	1.92	80.8	3.18	38.0	1 1/2	35.0	1 7/16
5R20-20FJ	1 1/8	1 5/8 - 12	51.6	2.03	85.6	3.37	50.0	2	43.0	1 3/4
5R24-24FJ	1 3/8	1 7/8 - 12	56.6	2.23	92.7	3.65	57.0	2 1/4	50.0	2
5R32-32FJ	1 13/16	2 1/2 - 12	65.3	2.57	112.5	4.43	73.0	2 7/8	55.0	2 1/2

Reference Hose Section for Coupling Compatibility

COUPLINGS

FJ45

JIC 37° FEMALE SWIVEL - 45° ELBOW

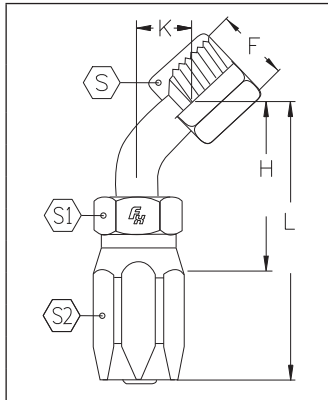

PART NUMBER	Hose Bore	F	H		L		K		S		S1		S2	
	INCH		[mm]	[in]	[mm]	[in]	[mm]	[in]	[mm]	[in]	[mm]	[in]	[mm]	[in]
5R04-04FJ45	3/16	7/16 - 20	27.9	1.10	46.7	1.84	8.1	0.32	14.2	9/16	14.2	9/16	15.8	5/8
5R05-05FJ45	1/4	1/2 - 20	32.5	1.28	26.9	1.06	8.9	0.35	15.8	5/8	14.2	9/16	17.4	11/16
5R06-06FJ45	5/16	9/16 - 18	33.5	1.32	56.6	2.23	9.9	0.39	17.4	11/16	14.2	9/16	20.6	13/16
5R08-08FJ45	13/32	3/4 - 16	46.7	1.84	75.7	2.98	13.7	0.54	22.2	7/8	17.4	11/16	23.8	15/16
5R10-10FJ45	1/2	7/8 - 14	49.5	1.95	82.0	3.23	15.7	0.62	25.4	1	22.2	7/8	28.5	1 1/8
5R12-12FJ45	5/8	1 1/16 - 12	56.1	2.21	96.0	3.78	19.3	0.76	31.7	1 1/4	28.5	1 1/8	31.7	1 1/4
5R16-16FJ45	7/8	1 5/16 - 12	56.6	2.23	90.4	3.56	22.6	0.89	38.1	1 1/2	34.9	1 3/8	36.5	1 7/16

FJ90

JIC 37° FEMALE SWIVEL - 90° ELBOW

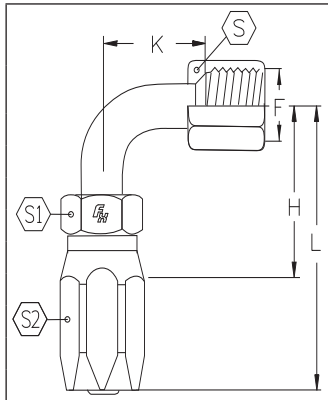

PART NUMBER	Hose Bore	F	H		L		K		S		S1		S2	
	INCH		[mm]	[in]	[mm]	[in]	[mm]	[in]	[mm]	[in]	[mm]	[in]	[mm]	[in]
5R04-04FJ90	3/16	7/16 - 20	25.4	1.00	44.4	1.75	17.3	0.68	14.2	9/16	14.2	9/16	15.8	5/8
5R05-05FJ90	1/4	1/2 - 20	30.0	1.18	49.8	1.96	19.3	0.76	15.8	5/8	14.2	9/16	17.4	11/16
5R06-06FJ90	5/16	9/16 - 18	31.2	1.23	53.8	2.12	21.3	0.84	17.4	11/16	17.4	11/16	20.6	13/16
5R08-08FJ90	13/32	3/4 - 16	40.6	1.60	69.8	2.75	27.7	1.09	22.2	7/8	26.9	11/16	23.8	15/16
5R10-10FJ90	7/8	7/8 - 14	41.9	1.65	74.4	2.93	31.2	1.23	25.4	1	22.2	7/8	28.5	1 1/8
5R12-12FJ90	5/8	1 1/16 - 12	55.1	2.17	95.2	3.75	50	1.81	31.7	1 1/4	31.7	1 1/4	31.7	1 1/4
5R16-16FJ90	7/8	1 5/16 - 12	57.9	2.28	89.9	3.54	54.3	2.14	38.1	1 1/2	38.1	1 1/2	36.5	1 7/16

FJ90L

JIC 37° FEMALE SWIVEL - 90° ELBOW LONG DROP

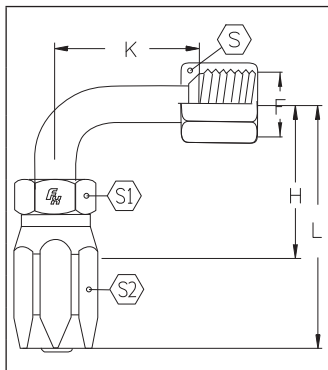

PART NUMBER	Hose Bore	F	H		L		K		S		S1		S2	
	INCH		[mm]	[in]	[mm]	[in]	[mm]	[in]	[mm]	[in]	[mm]	[in]	[mm]	[in]
5R04-04FJ90L	3/16	7/16 - 20	25.4	1.00	44.4	1.75	45.5	1.79	14.2	9/16	14.2	9/16	15.8	5/8
5R05-05FJ90L	1/4	1/2 - 20	30.0	1.18	49.8	1.96	45.2	1.78	15.8	5/8	14.2	9/16	17.4	11/16
5R06-06FJ90L	5/16	9/16 - 18	31.2	1.23	53.8	2.12	55.4	2.18	17.4	11/16	17.4	11/16	20.6	13/16
5R08-08FJ90L	13/32	3/4 - 16	40.6	1.60	69.8	2.75	61.7	2.43	22.2	7/8	22.2	7/8	23.8	15/16
5R10-10FJ90L	1/2	7/8 - 14	41.9	1.65	74.4	2.93	65.0	2.56	25.4	1	26.9	11/16	28.5	1 1/8
5R12-12FJ90L	5/8	1 1/16 - 12	55.1	2.17	95.2	3.75	94.7	3.73	31.7	1 1/4	31.7	1 1/4	31.7	1 1/4
5R16-16FJ90L	7/8	1 5/16 - 12	57.9	2.28	89.9	3.54	109.7	4.32	38.1	1 1/2	38.1	1 1/2	36.5	1 7/16

Reference Hose Section for Coupling Compatibility

COUPLINGS

MA SAE 45° MALE

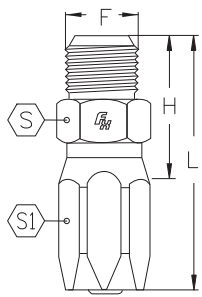

PART NUMBER	Hose Bore	F	H		L		S		S1	
	INCH		[mm]	[in]	[mm]	[in]	[mm]	[in]	[mm]	[in]
5R06-06MA	5/16	9/16 - 18	32.5	1.28	55.4	2.18	20.6	13/16	17.0	11/16
5R12-12MA	5/8	1 1/16 - 14	49.0	1.93	88.9	3.50	32.0	1 1/4	28.0	1 1/8

FA SAE 45° FEMALE SWIVEL

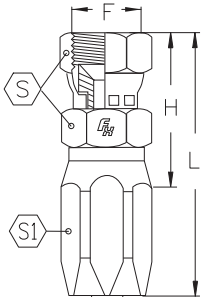

PART NUMBER	Hose Bore	F	H		L		S		S1	
	INCH		[mm]	[in]	[mm]	[in]	[mm]	[in]	[mm]	[in]
5R06-06FA	5/16	9/16 - 18	36.3	1.43	57.6	2.27	20.6	13/16	19.0	3/4
5R12-12FA	5/8	1 1/16 - 14	48.8	1.92	88.9	3.50	32.0	1 1/4	32.0	1 1/4

MIX SAE INVERTED FLARE MALE SWIVEL

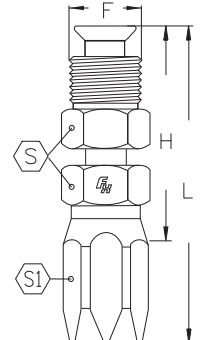

PART NUMBER	Hose Bore	T	A		B		S		S1	
	INCH		[mm]	[in]	[mm]	[in]	[mm]	[in]	[mm]	[in]
5R04-04MIX	3/16	7/16 - 24	43.4	1.71	62.5	2.46	9.0	3/8	16.0	5/8
5R05-05MIX	1/4	1/2 - 20	46.7	1.84	66.5	2.62	11.0	7/16	17.0	11/16
5R06-06MIX	5/16	9/16 - 18	46.0	1.81	68.8	2.71	12.0	1/2	20.6	13/16
5R08-08MIX	13/32	3/4 - 18	50.3	1.98	79.2	3.12	16.0	5/8	24.0	1

Reference Hose Section for Coupling Compatibility

ADAPTERS

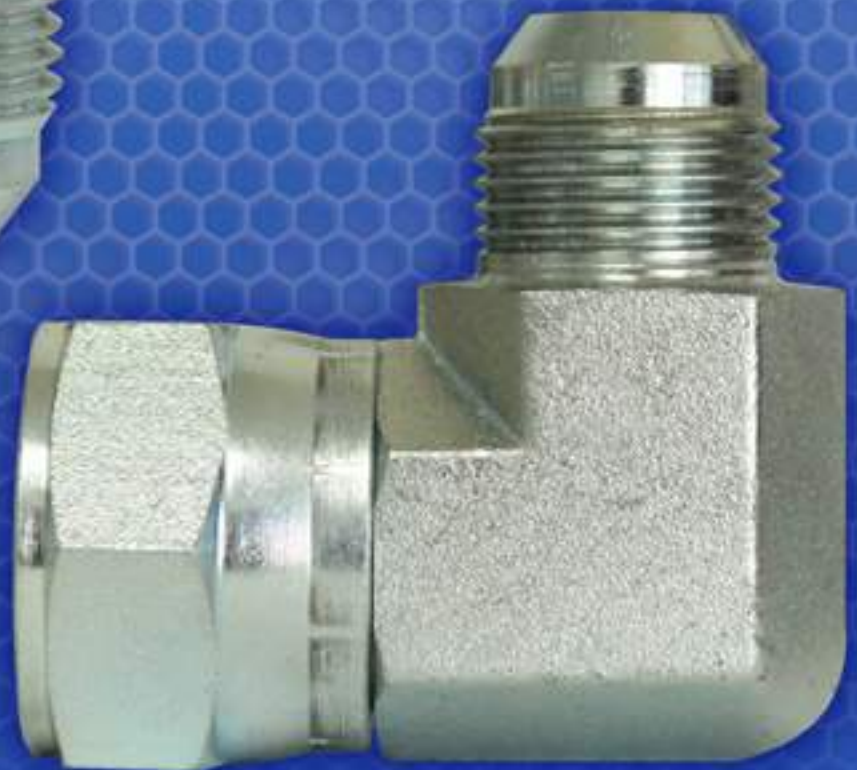

FLENTRAL

ADAPTERS

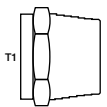
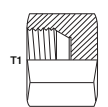
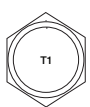
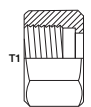
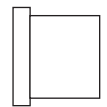
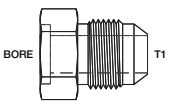
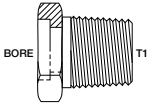
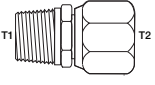
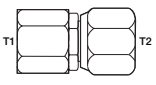
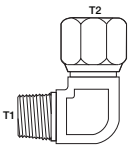
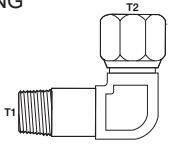
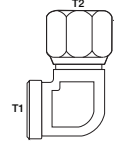
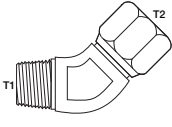
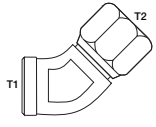
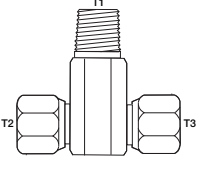
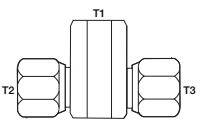
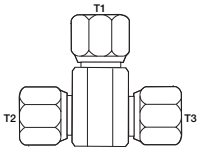
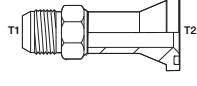
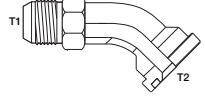
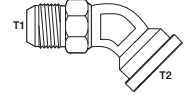
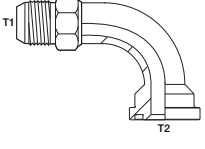
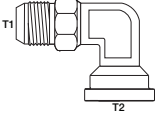
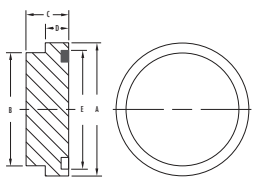
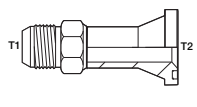
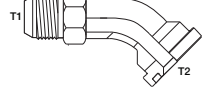
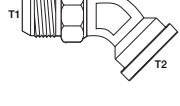
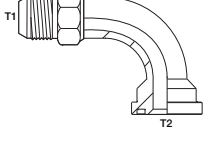
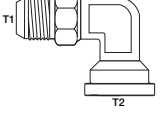
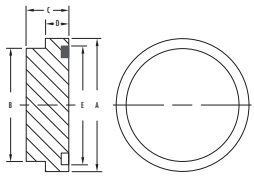
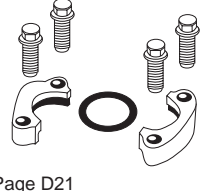
<p>0304 Standard Nut</p>  <p>Page D10</p>	<p>0304C JIC Cap</p>  <p>Page D10</p>	<p>0306 JIC Bulkhead Locknut</p>  <p>Page D10</p>	<p>0318 JIC Tube Nut</p>  <p>Page D11</p>	<p>0319 JIC Tube Sleeve 3 Piece</p>  <p>Page D11</p>
<p>0403 Bore/M-JIC Braze On (Unplated)</p>  <p>Page D11</p>	<p>0404 MP Straight</p>  <p>Page D12</p>	<p>1404 M-NPT/F-NPSM</p>  <p>Page D12</p>	<p>1405 F-NPT/F-NPSM</p>  <p>Page D13</p>	<p>1501 90° M-NPT/F-NPSM</p>  <p>Page D13</p>
<p>1501L 90° M-NPT/F-NPSM LONG</p>  <p>Page D14</p>	<p>1502 90° F-NPT/F-NPSM</p>  <p>Page D14</p>	<p>1503 45° M-NPT/F-NPSM</p>  <p>Page D15</p>	<p>1504 45° F-NPT/F-NPSM</p>  <p>Page D15</p>	<p>1601 Branch Tee M-NPT/ F-NPSM/F-NPSM</p>  <p>Page D16</p>
<p>1602 Tee F-NPT/F-NPSM/ F-NPSM</p>  <p>Page D16</p>	<p>1603 Tee F-NPSM Swivel Nuts</p>  <p>Page D16</p>	<p>1700 M-JIC/Flange Straight (Code 61)</p>  <p>Page D17</p>	<p>1703 45° M-JIC/ Flange (Code 61)</p>  <p>Page D17</p>	<p>1703FG Forged 45° M-JIC/ Flange (Code 61)</p>  <p>Page D18</p>
<p>1704 90° M-JIC/ Flange (Code 61)</p>  <p>Page D18</p>	<p>1704 FG Forged 90° M-JIC/ Flange (Code 61)</p>  <p>Page D18</p>	<p>1724 Flange Plug (Code 61)</p>  <p>Page D19</p>	<p>1800 M-JIC/Flange Straight (Code 62)</p>  <p>Page D19</p>	<p>1803 45° M-JIC/ Flange (Code 62)</p>  <p>Page D19</p>
<p>1803FG Forged 45° M-JIC/ Flange (Code 62)</p>  <p>Page D19</p>	<p>1804 90° M-JIC/ Flange (Code 62)</p>  <p>Page D20</p>	<p>1804FG Forged 90° M-JIC/ Flange (Code 62)</p>  <p>Page D20</p>	<p>1824 Flange Plug (Code 62)</p>  <p>Page D20</p>	<p>1901 Split Flange Kit (Code 61)</p>  <p>Page D21</p>

ADAPTERS

<p>1902 Split Flange Kit (Code 62)</p> <p>Page D21</p>	<p>1903 Caterpillar® Split Flange Kit (Code 62)</p> <p>Page D21</p>	<p>1927-61 F-NPT/Flange Kit (Code 61)</p> <p>Page D21</p>	<p>2403 M-JIC/M-JIC Straight</p> <p>Page D22</p>	<p>2403LH M-JIC/M-JIC Large Hex Straight</p> <p>Page D22</p>
<p>2404 M-JIC/M-NPT Straight</p> <p>Page D23</p>	<p>2404L M-JIC/M-NPT Long Straight</p> <p>Page D24</p>	<p>2404LL M-JIC/M-NPT Extra Long Straight</p> <p>Page D24</p>	<p>2405 M-JIC/F-NPT Straight</p> <p>Page D25</p>	<p>2406 F-JIC/M-JIC</p> <p>Page D26</p>
<p>2408 JIC Plug</p> <p>Page D27</p>	<p>2500 90° M-JIC/M-JIC</p> <p>Page D27</p>	<p>2501 90° M-JIC/M-NPT</p> <p>Page D28</p>	<p>2501L 90° M-JIC/M-NPT Long</p> <p>Page D29</p>	<p>2501LL 90° M-JIC/M-NPT Extra Long</p> <p>Page D29</p>
<p>2501LLL 90° M-JIC/M-NPT Extra Extra Long</p> <p>Page D30</p>	<p>2502 90° M-JIC/F-NPT</p> <p>Page D30</p>	<p>2503 45° M-JIC/M-NPT</p> <p>Page D31</p>	<p>2504 45° M-JIC/M-JIC</p> <p>Page D31</p>	<p>2505 45° M-JIC/F-NPT</p> <p>Page D32</p>
<p>2601 Branch Tee M-JIC/ M-JIC/M-NPT</p> <p>Page D32</p>	<p>2602 Branch Tee M-JIC/ M-JIC/F-NPT</p> <p>Page D33</p>	<p>2603 Tee M-JIC/M-JIC/M-JIC</p> <p>Page D33</p>	<p>2605 Run Tee M-JIC/M-NPT/ M-JIC</p> <p>Page D34</p>	<p>2606 Run Tee M-JIC/F-NPT /M-JIC</p> <p>Page D34</p>
<p>2609 Run Tee M-JIC/F-NPT/ F-NPT</p> <p>Page D34</p>	<p>2613 Run Tee M-NPT/ F-NPT/M-JIC</p> <p>Page D35</p>	<p>2650 Cross M-JIC</p> <p>Page D35</p>	<p>2700LN M-JIC Bulkhead Straight</p> <p>Page D35</p>	<p>2701LN 90° M-JIC Bulkhead</p> <p>Page D36</p>



ADAPTERS

<p>2702LN 45° M-JIC Bulkhead</p> <p>Page D36</p>	<p>2703LN Branch Tee M-JIC Bulkhead</p> <p>Page D36</p>	<p>2704LN Run Tee M-JIC Bulkhead</p> <p>Page D37</p>	<p>2705LN F-NPT/M-JIC Bulkhead</p> <p>Page D37</p>	<p>2706LN M-NPT/M-JIC Bulkhead</p> <p>Page D37</p>
<p>3474 M-ORB/ADJ M-ORB</p> <p>Page D38</p>	<p>4404 HB/M-NPT Straight</p> <p>Page D38</p>	<p>4501 90° HB/M-NPT</p> <p>Page D39</p>	<p>4503 45° HB/M-NPT</p> <p>Page D39</p>	<p>4601 90° HB/M-ORB</p> <p>Page D40</p>
<p>4603 45° HB/M-ORB</p> <p>Page D40</p>	<p>4604 HB/M-ORB Straight</p> <p>Page D41</p>	<p>5000 F-NPT/F-NPT</p> <p>Page D41</p>	<p>5404 M-NPT/M-NPT</p> <p>Page D42</p>	<p>5405 M-NPT/F-NPT</p> <p>Page D42</p>
<p>5406 M-NPT/F-NPT</p> <p>Page D43</p>	<p>5406C NPT Cap</p> <p>Page D43</p>	<p>5406P NPT Plug</p> <p>Page D43</p>	<p>5406HP NPT Hollow Hex Plug</p> <p>Page D44</p>	<p>5406SHP Square Head Pipe Plug</p> <p>Page D44</p>
<p>5500 90° M-NPT/M-NPT</p> <p>Page D44</p>	<p>5501 45° M-NPT/M-NPT</p> <p>Page D45</p>	<p>5502 90° M-NPT/F-NPT</p> <p>Page D45</p>	<p>5503 45° M-NPT/F-NPT</p> <p>Page D45</p>	<p>5504 90° F-NPT/F-NPT</p> <p>Page D46</p>
<p>5505 45° F-NPT/F-NPT</p> <p>Page D46</p>	<p>5600 Tee M-NPT</p> <p>Page D46</p>	<p>5601 Branch Tee M-NPT/M-NPT/F-NPT</p> <p>Page D46</p>	<p>5602 Run Tee M-NPT/F-NPT/F-NPT</p> <p>Page D47</p>	<p>5603 Run Tee M-NPT/F-NPT/M-NPT</p> <p>Page D47</p>





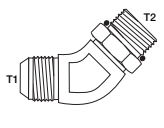
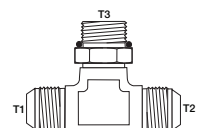
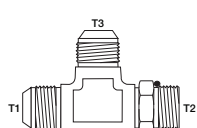
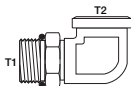
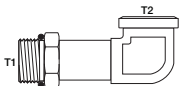
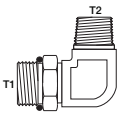
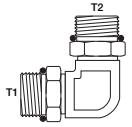
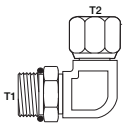
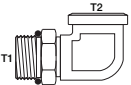
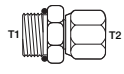
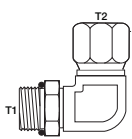
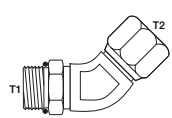
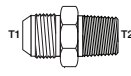
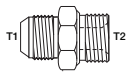
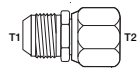
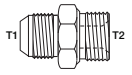
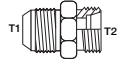
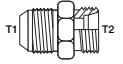
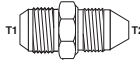
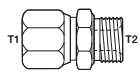
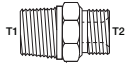
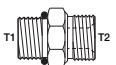
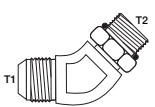
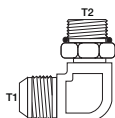
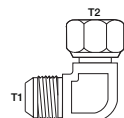
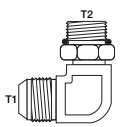
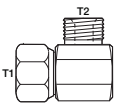

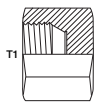



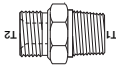
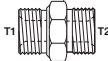
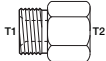

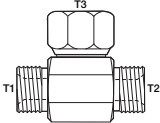
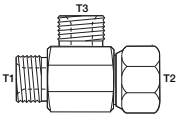
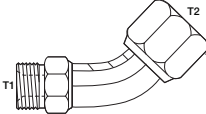
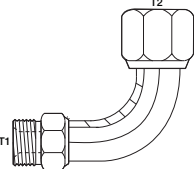
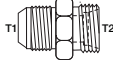
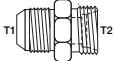
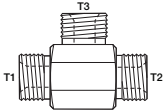
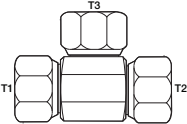

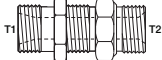

ADAPTERS

<p>5604 Branch Tee F-NPT/F-NPT/M-NPT</p> <p>Page D47</p>	<p>5605 Tee F-NPT</p> <p>Page D47</p>	<p>5652 Cross F-NPT</p> <p>Page D48</p>	<p>6400 M-JIC/M-ORB</p> <p>Page D48</p>	<p>6400L M-JIC/M-ORB Long</p> <p>Page D49</p>
<p>6401 M-ORB/M-NPT</p> <p>Page D50</p>	<p>6402 M-ORB/F-JIC</p> <p>Page D50</p>	<p>6404 F-ORB/M-NPT</p> <p>Page D50</p>	<p>6405 M-ORB/F-NPT</p> <p>Page D51</p>	<p>6408 ORB Plug</p> <p>Page D52</p>
<p>6408H ORB Hollow Hex Plug</p> <p>Page D52</p>	<p>6410 M-ORB/F-ORB</p> <p>Page D53</p>	<p>6464 M-ORB/M-ORB Straight</p> <p>Page D54</p>	<p>6500 90° M-JIC/F-JIC</p> <p>Page D54</p>	<p>6501 90° M-NPT/F-JIC</p> <p>Page D55</p>
<p>6502 45° M-JIC/F-JIC</p> <p>Page D55</p>	<p>6504 M-JIC/F-JIC Straight</p> <p>Page D55</p>	<p>6505 M-NPT/F-JIC Straight</p> <p>Page D56</p>	<p>6506 F-NPT/F-JIC Straight</p> <p>Page D56</p>	<p>6565 F-JIC/F-JIC Straight</p> <p>Page D56</p>
<p>6600 Branch Tee M-JIC/M-JIC F-JIC</p> <p>Page D57</p>	<p>6602 Run Tee M-JIC/F-JIC M-JIC</p> <p>Page D57</p>	<p>6603 Swivel Run Tee F-JIC/F-JIC/M-JIC</p> <p>Page D57</p>	<p>6606 Swivel Tee F-JIC</p> <p>Page D58</p>	<p>6701 90° M-JIC/F-JIC Bent Tube</p> <p>Page D58</p>
<p>6701L 90° M-JIC/F-JIC Bent Tube Long</p>	<p>6801 90° M-JIC/M-ORB</p> <p>Page D59</p>	<p>6801L 90° M-JIC/M-ORB Long</p> <p>Page D60</p>	<p>6801LL 90° M-JIC/M-ORB Extra Long</p> <p>Page D60</p>	<p>6801LLL 90° M-JIC/M-ORB Extra Extra Long</p>

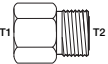
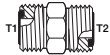
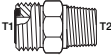
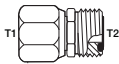

ADAPTERS

6802 45° M-JIC/M-ORB  Page D61	6803 Branch Tee M-JIC/M-JIC/M-ORB  Page D62	6804 Run Tee M-JIC/M-ORB/M-JIC  Page D62	6805 90° M-ORB/F-NPT  Page D63	6805L 90° M-ORB/F-NPT Long  Page D63
6806 90° M-ORB/M-NPT  Page D63	6807 90° M-ORB/M-ORB  Page D64	6809 90° M-ORB/F-JIC  Page D64	6815 90° M-ORB/F-ORB  Page D64	6900 M-ORB/F-NPSM  Page D65
6901 90° M-ORB/F-NPSM  Page D66	6902 45° M-ORB/F-NPSM  Page D66	7000 M-JIC/M-BSPT Straight  Page D67	7002 M-JIC/M-BSPP Straight  Page D67	7004 M-JIC/F-BSPP  Page D68
7005 M-JIC/M-Metric Port  Page D68	7005L M-JIC/M-Metric Light  Page D68	7005S M-JIC/M-Metric Heavy  Page D69	7009 M-JIC/M-Komatsu  Page D69	7022 F-JIC Swivel/M-BSPP  Page D69
7032 M-NPT/M-BSPP  Page D70	7062 M-ORB/M-BSPP  Page D70	7102 45° M-JIC/M-BSPP  Page D71	7202 90° M-JIC/M-BSPP  Page D71	7204 90° M-JIC/F-BSPP  Page D71
7205 90° M-JIC/M-Metric  Page D71	7222 F-JIC/90° M-BSPP  Page D72	7588P JIS Plug  Page D72	7599P Komatsu Plug  Page D72	7688C JIS Cap  Page D72





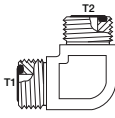
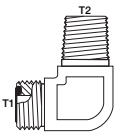
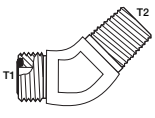
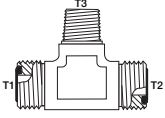
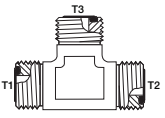
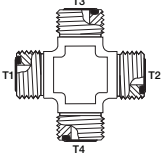
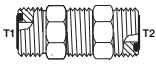
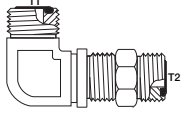
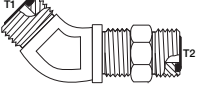
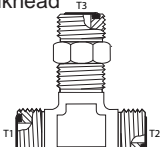
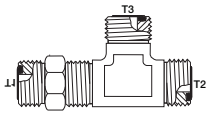
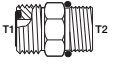

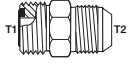
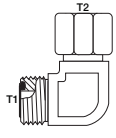
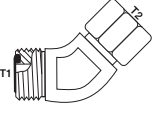
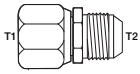
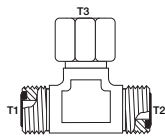
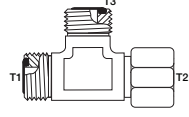
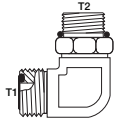
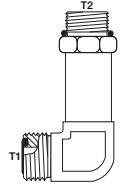
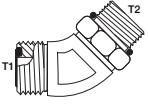
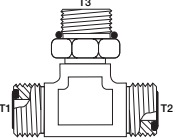
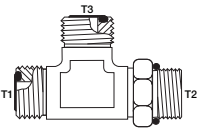
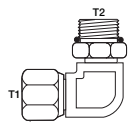
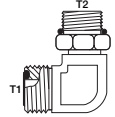
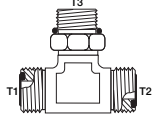
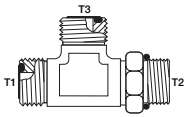
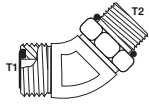
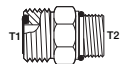
ADAPTERS

8800 Metric Bonded Seal  Page D72	9020 M-BSPP/M-BSPT Straight  Page D73	9022 M-BSPP/M-BSPP Straight  Page D73	9023 M-BSPP/F-BSPP Straight  Page D74	9024 M-BSPP/F-BSPP  Page D74
9087 Branch Tee M-BSPP/ M-BSPP/F-BSPP  Page D74	9090 Run Tee M-BSPP/ F-BSPP/M-BSPP  Page D74	9124 45° M-BSPP/ F-BSPP Bent Tube  Page D75	9224L 90° M-BSPP/ F-BSPP Bent Tube  Page D75	9245 M-JIC/M-JSW  Page D75
9247 M-JIC/M-Kobelco  Page D75	9322 Tee M-BSPP  Page D75	9344 Tee F-BSPP  Page D76	9522P M-BSPP Plug  Page D76	9610 Metric Plug Light  Page D76
9611 Metric Plug Heavy  Page D76	9620 Metric Cap Light  Page D77	9621 Metric Cap Heavy  Page D77	9644C F-BSPP Cap  Page D77	9722LN M-BSPP/M-BSPP Bulkhead  Page D77
9900 BSP Bonded Seal  Page D78	FS0304 ORFS Cap  Page D79	FS0306 ORFS Bulkhead Locknut  Page D79	FS0318 ORFS Tube Nut  Page D79	FS0319 ORFS Sleeve Braze Style  Page D79
FS0403 Bore/M-ORFS Straight Braze On  Page D80	FS2403 M-ORFS/M-ORFS Straight  Page D80	FS2404 M-ORFS/M-NPT Straight  Page D81	FS2406 F-ORFS/M-ORFS  Page D81	FS2408 ORFS/Hex Plug  Page D82

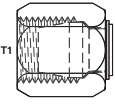
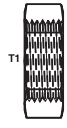
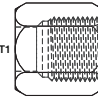
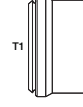
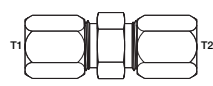
ADAPTERS

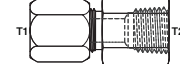
FS2500 90° M-ORFS/M-ORFS  Page D82	FS2501 90° M-ORFS/M-NPT  Page D82	FS2503 45° M-ORFS/M-NPT  Page D83	FS2601 Branch Tee M-ORFS/ M-ORFS/M-NPT  Page D83	FS2603 Tee M-ORFS  Page D83
FS2650 Cross M-ORFS  Page D84	FS2700LN M-ORFS/M-ORFS/ Bulkhead  Page D84	FS2701LN 90° M-ORFS/M-ORFS/ Bulkhead  Page D84	FS2702LN 45° M-ORFS/M-ORFS/ Bulkhead  Page D85	FS2703LN Run Tee M-ORFS/ M-ORFS/ORFS Bulkhead  Page D85
FS2704LN Run Tee M-ORFS/ ORFS Bulkhead  Page D85	FS6400 M-ORFS/M-ORB  Page D86	FS6402 M-ORFS/F-JIC Straight  Page D87	FS6403 M-ORFS/M-JIC  Page D87	FS6500 90° M-ORFS/F-ORFS  Page D87
FS6502 45° M-ORFS/F-ORFS  Page D87	FS6504 F-ORFS/M-JIC Straight  Page D88	FS6600 Branch Tee M-ORFS/ M-ORFS/F-ORFS  Page D88	FS6602 Run Tee M-ORFS/ F-ORFS/M-ORFS  Page D88	FS6801 90° M-ORFS/M-ORB  Page D89
FS6801L 90° M-ORFS/M-ORB Long  Page D89	FS6802 45° M-ORFS/M-ORB  Page D90	FS6803 Branch Tee M-ORFS/ M-ORFS/M-ORB  Page D90	FS6804 Run Tee M-ORFS/ M-ORB/M-ORFS  Page D91	FS6809 90° F-ORFS/M-ORB  Page D91
FS7205 90° M-ORFS/ M-Metric Port  Page D91	FS7210 M-ORFS/M-ORFS/ M-Metric Port  Page D92	FS7215 M-ORFS/M-Metric Port/ M-ORFS Tee  Page D92	FS7300 M-ORFS/M-Metric Port 45° Elbow  Page D92	FS7640 M-ORFS/M-Metric Port Straight  Page D93

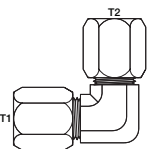
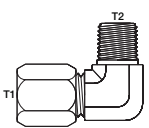
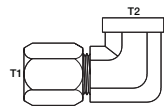
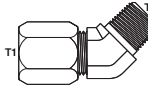
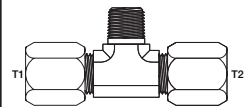
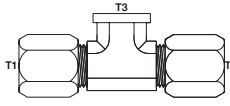
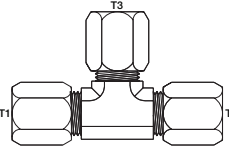
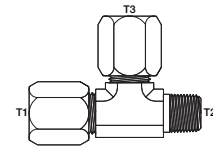
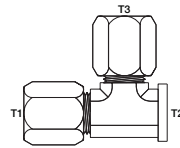
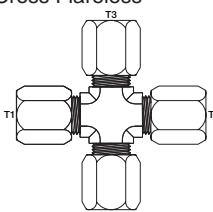
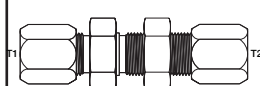
ADAPTERS

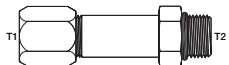
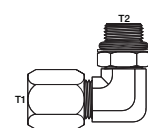
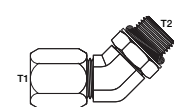
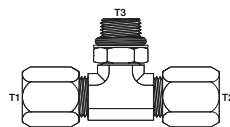
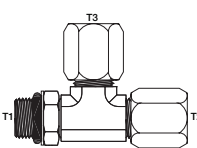
<p>C0304 Flareless Cap</p>  <p>Page D94</p>	<p>C0306 Flareless Bulkhead Locknut</p>  <p>Page D94</p>	<p>C0318 Flareless Nut</p>  <p>Page D94</p>	<p>C0319 Flareless Compression Sleeve</p>  <p>Page D95</p>	<p>C2403 Flareless/Flareless</p>  <p>Page D95</p>
<p>C2403LH Flareless/Flareless - Large Hex</p>  <p>Page D95</p>	<p>C2404 Flareless/M-NPT</p>  <p>Page D96</p>	<p>C2405 Flareless/F-NPT</p>  <p>Page D96</p>	<p>C2406 Standpipe/Flareless Reducer</p>  <p>Page D97</p>	<p>C2408 Flareless Plug</p>  <p>Page D97</p>
<p>C2500 90° Flareless/Flareless</p>  <p>Page D97</p>	<p>C2501 90° Flareless/M-NPT</p>  <p>Page D98</p>	<p>C2502 90° Flareless/F-NPT</p>  <p>Page D98</p>	<p>C2503 45° Flareless/M-NPT</p>  <p>Page D99</p>	<p>C2601 Tee Flareless/Flareless /M-NPT</p>  <p>Page D99</p>
<p>C2602 Tee Flareless/Flareless /F-NPT</p>  <p>Page D99</p>	<p>C2603 Tee Flareless</p>  <p>Page D99</p>	<p>C2605 Tee Flareless/M-NPT/ Flareless</p>  <p>Page D100</p>	<p>C2606 Tee Flareless/F-NPT/ Flareless</p>  <p>Page D100</p>	<p>C2650 Cross Flareless</p>  <p>Page D100</p>
<p>C2700 Flareless/Flareless Bulkhead</p>  <p>Page D101</p>	<p>C6400 Flareless/M-ORB</p>  <p>Page D101</p>	<p>C6400L Flareless/M-ORB Long</p>  <p>Page D101</p>	<p>C6801 90° Flareless/M-ORB</p>  <p>Page D102</p>	<p>C6802 45° Flareless/M-ORB</p>  <p>Page D102</p>
<p>C6803 Tee Flareless/Flareless/ M-ORB</p>  <p>Page D102</p>	<p>C6804 Tee M-ORB/Flareless/ Flareless</p>  <p>Page D102</p>			

ADAPTERS

0304 STANDARD NUT

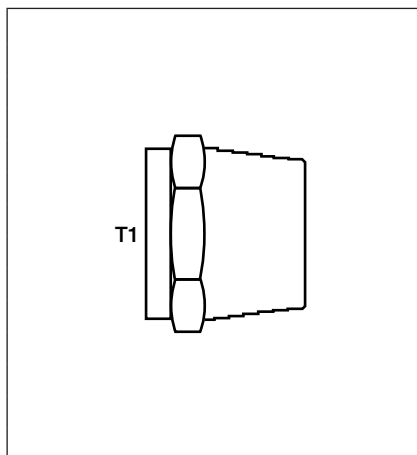

PART NUMBER	T1
0304-02	5/16 - 24
0304-03	3/8 - 24
0304-04	7/16 - 20
0304-05	1/2 - 20
0304-06	9/16 - 18
0304-08	3/4 - 16
0304-10	7/8 - 14
0304-12	1 1/16 - 12
0304-14	1 3/16 - 12
0304-16	1 5/16 - 12
0304-20	1 5/8 - 12
0304-24	1 7/8 - 12
0304-32	2 1/2 - 12

0304C JIC CAP

SAE# 070112

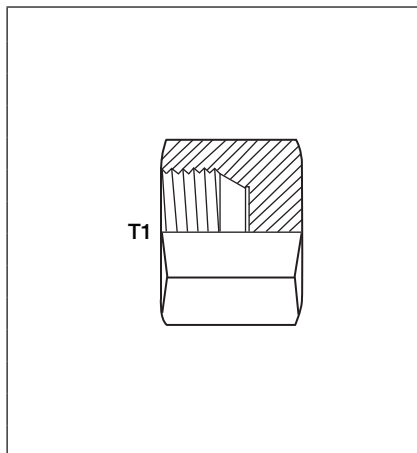

PART NUMBER	T1
0304C-02	5/16 - 24
0304C-03	3/8 - 24
0304C-04	7/16 - 20
0304C-05	1/2 - 20
0304C-06	9/16 - 18
0304C-08	3/4 - 16
0304C-10	7/8 - 14
0304C-12	1 1/16 - 12
0304C-14	1 3/16 - 12
0304C-16	1 5/16 - 12
0304C-20	1 5/8 - 12
0304C-24	1 7/8 - 12
0304C-32	2 1/2 - 12

0306 JIC BULKHEAD LOCKNUT

SAE# 51860

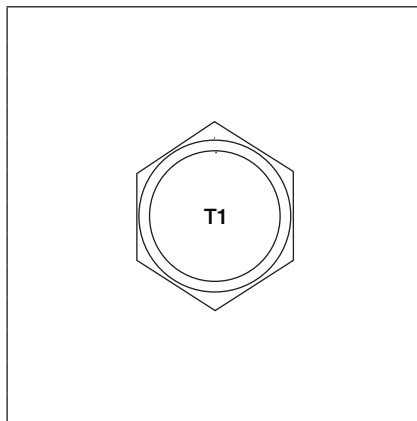

PART NUMBER	T1
0306-03	3/8 - 24
0306-04	7/16 - 20
0306-05	1/2 - 20
0306-06	9/16 - 18
0306-08	3/4 - 16
0306-10	7/8 - 14
0306-12	1 1/16 - 12
0306-14	1 3/16 - 12
0306-16	1 5/16 - 12
0306-20	1 5/8 - 12
0306-24	1 7/8 - 12
0306-32	2 1/2 - 12

ADAPTERS

0318

JIC TUBE NUT

SAE# 070110

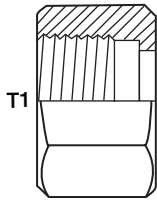

PART NUMBER	T1	TUBE OD
0318-04	7/16 - 20	1/4
0318-05	1/2 - 20	5/16
0318-06	9/16 - 18	3/8
0318-08	3/4 - 16	1/2
0318-10	7/8 - 14	5/8
0318-12	1 1/16 - 12	3/4
0318-14	1 3/16 - 12	3/4
0318-16	1 5/16 - 12	7/8
0318-20	1 5/8 - 12	1
0318-24	1 7/8 - 12	1 1/2
0316-32	2 1/2 - 12	2

0319

JIC TUBE SLEEVE 3 PIECE

SAE# 070115

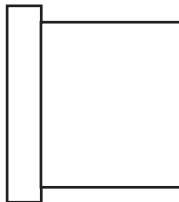

PART NUMBER	TUBE OD
0319-04	1/4
0319-05	5/16
0319-06	3/8
0319-08	1/2
0319-10	5/8
0319-12	3/4
0319-14	7/8
0319-16	1
0319-20	1 1/4
0319-24	1 1/2
0319-32	2

0403

BORE / M-JIC BRAZE ON (UNPLATED)

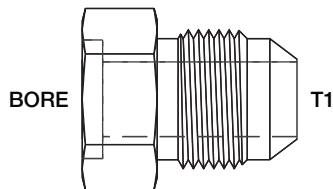

PART NUMBER	BORE	T1
0403-0404	1/4	7/16 - 20
0403-0505	5/16	1/2 - 20
0403-0606	3/8	9/16 - 18
0403-0608	3/8	3/4 - 16
0403-0808	1/2	3/4 - 16
0403-1010	5/8	7/8 - 14
0403-1212	3/4	1 1/16 - 12
0403-1414	7/8	1 3/16 - 12
0403-1616	1	1 5/16 - 12
0403-1620	1	1 5/8 - 12
0403-2016	1 1/4	1 5/16 - 12
0403-2020	1 1/4	1 5/8 - 12
0403-2424	1 1/2	1 7/8 - 12
0403-3232	2	2 1/2 - 12

ADAPTERS

0404 BORE / MP BRAZE ON

	PART NUMBER	BORE	T1
	0404-0402	1/4	1/8 - 27
	0404-0604	3/8	1/4 - 18
	0404-0806	1/2	3/8 - 18
	0404-1008	5/8	1/2 - 14
	0404-1212	3/4	1 1/16 - 12
	0404-1616	1	1 5/16 - 12
	0404-2020	1 1/4	1 5/8 - 12
	0404-2424	1 1/2	1 7/8 - 12
0404-3232	2	2 1/2 - 12	

1404 M-NPT / F-NPSM

SAE# 140130

	PART NUMBER	T1	T2
	1404-0204	1/8 - 27	1/4 - 18
	1404-0402	1/4 - 18	1/8 - 27
	1404-0404	1/4 - 18	1/4 - 18
	1404-0406	1/4 - 18	3/8 - 18
	1404-0604	3/8 - 18	1/4 - 18
	1404-0606	3/8 - 18	3/8 - 18
	1404-0608	3/8 - 18	1/2 - 14
	1404-0804	1/2 - 14	1/4 - 18
	1404-0806	1/2 - 14	3/8 - 18
	1404-0808	1/2 - 14	1/2 - 14
	1404-0812	1/2 - 14	3/4 - 14
	1404-1208	3/4 - 14	1/2 - 14
	1404-1212	3/4 - 14	3/4 - 14
	1404-1216	3/4 - 14	1 - 11 1/2
	1404-1612	1 - 11 1/2	3/4 - 14
	1404-1616	1 - 11 1/2	1 - 11 1/2
	1404-1620	1 - 11 1/2	1 1/4 - 11 1/2
	1404-2016	1 1/4 - 11 1/2	1 - 11 1/2
	1404-2020	1 1/4 - 11 1/2	1 1/4 - 11 1/2
	1404-2024	1 1/4 - 11 1/2	1 1/2 - 11 1/2
	1404-2420	1 1/2 - 11 1/2	1 1/4 - 11 1/2
	1404-2424	1 1/2 - 11 1/2	1 1/2 - 11 1/2
	1404-3232	2 - 11 1/2	2 - 11 1/2

ADAPTERS

1405

F-NPT / F-NPSM

SAE# 140131

	PART NUMBER		T1	T2
		1405-0202		1/8 - 27
1405-0204			1/8 - 27	1/4 - 18
1405-0404			1/4 - 18	1/4 - 18
1405-0406			1/4 - 18	3/8 - 18
1405-0604			3/8 - 18	1/4 - 18
1405-0606			3/8 - 18	3/8 - 18
1405-0608			3/8 - 18	1/2 - 14
1405-0804			1/2 - 14	1/4 - 18
1405-0806			1/2 - 14	3/8 - 18
1405-0808			1/2 - 14	1/2 - 14
1405-1208			3/4 - 14	1/2 - 14
1405-1212			3/4 - 14	3/4 - 14
1405-1612			1 - 11 1/2	3/4 - 14
1405-1616			1 - 11 1/2	1 - 11 1/2
1405-2020			1 1/4 - 11 1/2	1 1/4 - 11 1/2
1405-2424			1 1/2 - 11 1/2	1 1/2 - 11 1/2
1405-3232			2 - 11 1/2	2 - 11 1/2

1501

90° M-NPT / F-NPSM

SAE# 140230

	PART NUMBER		T1	T2
		1501-0202		1/8 - 27
1501-0204			1/8 - 27	1/4 - 18
1501-0402			1/4 - 18	1/8 - 27
1501-0404			1/4 - 18	1/4 - 18
1501-0406			1/4 - 18	3/8 - 18
1501-0408			1/4 - 18	1/2 - 14
1501-0604			3/8 - 18	1/4 - 18
1501-0606			3/8 - 18	3/8 - 18
1501-0608			3/8 - 18	1/2 - 14
1501-0804			1/2 - 14	1/4 - 18
1501-0806			1/2 - 14	3/8 - 18
1501-0808			1/2 - 14	1/2 - 14
1501-0812			1/2 - 14	3/4 - 14
1501-1206			3/4 - 14	3/8 - 18
1501-1208			3/4 - 14	1/2 - 14
1501-1212			3/4 - 14	3/4 - 14
1501-1216			3/4 - 14	1 - 11 1/2
1501-1608			1 - 11 1/2	1/2 - 14
1501-1612			1 - 11 1/2	3/4 - 14
1501-1616			1 - 11 1/2	1 - 11 1/2
1501-1620			1 - 11 1/2	1 1/4 - 11 1/2
1501-2016			1 1/4 - 11 1/2	1 - 11 1/2
1501-2020			1 1/4 - 11 1/2	1 1/4 - 11 1/2
1501-2024			1 1/4 - 11 1/2	1 1/2 - 11 1/2
1501-2420			1 1/2 - 11 1/2	1 1/4 - 11 1/2
1501-2424			1 1/2 - 11 1/2	1 1/2 - 11 1/2
1501-3232			2 - 11 1/2	2 - 11 1/2

ADAPTERS

1501L 90° M-NPT / F-NPSM LONG

	PART NUMBER	T1	T2
	1501L-0202	1/8 - 27	1/8 - 27
	1501L-0404	1/4 - 18	1/4 - 18
	1501L-0606	3/8 - 18	3/8 - 18
	1501L-0808	1/2 - 14	1/2 - 14
	1501L-1212	3/4 - 14	3/4 - 14
	1501L-1616	1 - 11½	1 - 11½

1502 90° F-NPT / F-NPSM

SAE# 140231

	PART NUMBER	T1	T2
	1502-0202	1/8 - 27	1/8 - 27
	1502-0402	1/4 - 18	1/8 - 27
	1502-0404	1/4 - 18	1/4 - 18
	1502-0406	1/4 - 18	3/8 - 18
	1502-0604	3/8 - 18	1/4 - 18
	1502-0606	3/8 - 18	3/8 - 18
	1502-0608	3/8 - 18	1/2 - 14
	1502-0804	3/4 - 16	1/4 - 18
	1502-0806	1/2 - 14	3/8 - 18
	1502-0808	1/2 - 14	1/2 - 14
	1502-0812	1/2 - 14	3/4 - 14
	1502-1208	3/4 - 14	1/2 - 14
	1502-1212	3/4 - 14	3/4 - 14
	1502-1216	3/4 - 14	1 - 11½
	1502-1612	1 - 11½	3/4 - 14
	1502-1616	1 - 11½	1 - 11½
	1502-2020	1¼ - 11½	1¼ - 11½
	1502-2424	1½ - 11½	1½ - 11½
	1502-3232	2 - 11½	2 - 11½

ADAPTERS

1503

45° M-NPT / F-NPSM

SAE# 140330

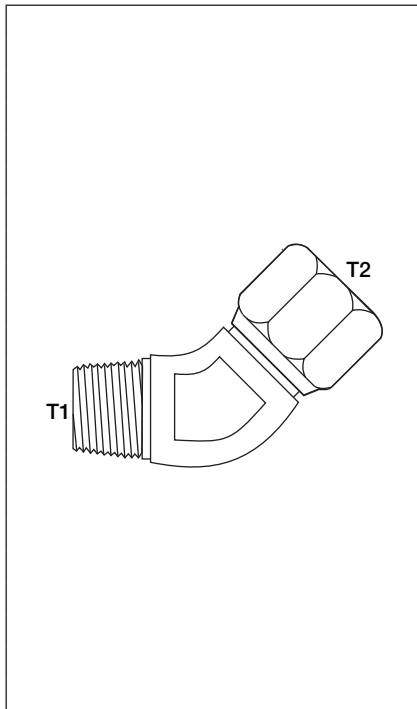

PART NUMBER	T1	T2
1503-0202	1/8 - 27	1/8 - 27
1503-0204	1/8 - 27	1/4 - 18
1503-0404	1/4 - 18	1/4 - 18
1503-0406	1/4 - 18	3/8 - 18
1503-0604	3/8 - 18	1/4 - 18
1503-0606	3/8 - 18	3/8 - 18
1503-0608	3/8 - 18	1/2 - 14
1503-0804	1/2 - 14	1/4 - 18
1503-0806	1/2 - 14	3/8 - 18
1503-0808	1/2 - 14	1/2 - 14
1503-0812	1/2 - 14	3/4 - 14
1503-1208	3/4 - 14	1/2 - 14
1503-1212	3/4 - 14	3/4 - 14
1503-1216	3/4 - 14	1 - 11 1/2
1503-1612	1 - 11 1/2	3/4 - 14
1503-1616	1 - 11 1/2	1 - 11 1/2
1503-1620	1 - 11 1/2	1 1/4 - 11 1/2
1503-2016	1 1/4 - 11 1/2	1 - 11 1/2
1503-2020	1 1/4 - 11 1/2	1 1/4 - 11 1/2
1503-2424	1 1/2 - 11 1/2	1 1/2 - 11 1/2
1503-3232	2 - 11 1/2	2 - 11 1/2

1504

45° F-NPT / F-NPSM

SAE# 140331

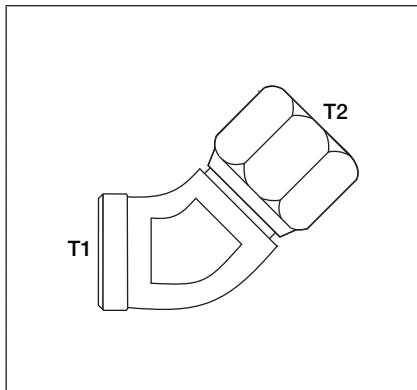

PART NUMBER	T1	T2
1504-0202	1/8 - 27	1/8 - 27
1504-0404	1/4 - 18	1/4 - 18
1504-0604	3/8 - 18	1/4 - 18
1504-0606	3/8 - 18	3/8 - 18
1504-0806	1/2 - 14	3/8 - 18
1504-0808	1/2 - 14	1/2 - 14
1504-1212	3/4 - 14	3/4 - 14
1504-1612	1 - 11 1/2	3/4 - 14
1504-1616	1 - 11 1/2	1 - 11 1/2
1504-2020	1 1/4 - 11 1/2	1 1/4 - 11 1/2
1504-2424	1 1/2 - 11 1/2	1 1/2 - 11 1/2

ADAPTERS

1601 BRANCH TEE M-NPT / F-NPSM / F-NPSM

	PART NUMBER	T1	T2	T3
	1601-020202	1/8 - 27	1/8 - 27	1/8 - 27
	1601-040404	1/4 - 18	1/4 - 18	1/4 - 18
	1601-040606	1/4 - 18	3/8 - 18	3/8 - 18
	1601-060404	3/8 - 18	1/4 - 18	1/4 - 18
	1601-060606	3/8 - 18	3/8 - 18	3/8 - 18
	1601-080404	1/2 - 14	1/4 - 18	1/4 - 18
	1601-080606	1/2 - 14	3/8 - 18	3/8 - 18
	1601-080808	1/2 - 14	1/2 - 14	1/2 - 14
	1601-120808	3/4 - 14	1/2 - 14	1/2 - 14
	1601-121212	3/4 - 14	3/4 - 14	3/4 - 14
	1601-121616	3/4 - 14	1 - 11 1/2	1 - 11 1/2
	1601-161212	1 - 11 1/2	3/4 - 14	3/4 - 14
	1601-161616	1 - 11 1/2	1 - 11 1/2	1 - 11 1/2
	1601-202020	1 1/4 - 11 1/2	1 1/4 - 11 1/2	1 1/4 - 11 1/2
1601-242424	1 1/2 - 11 1/2	1 1/2 - 11 1/2	1 1/2 - 11 1/2	

1602 TEE F-NPT / F-NPSM / F-NPSM

	PART NUMBER	T1	T2	T3
	1602-020202	1/8 - 27	1/8 - 27	1/8 - 27
	1602-040404	1/4 - 18	1/4 - 18	1/4 - 18
	1602-060606	3/8 - 18	3/8 - 18	3/8 - 18
	1602-080606	1/2 - 14	3/8 - 18	3/8 - 18
	1602-080808	1/2 - 14	1/2 - 14	1/2 - 14
	1602-120808	3/4 - 14	1/2 - 14	1/2 - 14
	1602-121212	3/4 - 14	3/4 - 14	3/4 - 14
	1602-161616	1 - 11 1/2	1 - 11 1/2	1 - 11 1/2
	1602-202020	1 1/4 - 11 1/2	1 1/4 - 11 1/2	1 1/4 - 11 1/2

1603 TEE F-NPSM SWIVEL NUTS

	PART NUMBER	T1	T2	T3
	1603-020202	1/8 - 27	1/8 - 27	1/8 - 27
	1603-040404	1/4 - 18	1/4 - 18	1/4 - 18
	1603-060606	3/8 - 18	3/8 - 18	3/8 - 18
	1603-080808	1/2 - 14	1/2 - 14	3/4 - 14
	1603-121212	3/4 - 14	3/4 - 14	1 - 11 1/2
	1603-161616	1 - 11 1/2	1 - 11 1/2	1 1/4 - 11 1/2
	1603-202020	1 1/4 - 11 1/2	1 1/4 - 11 1/2	1 1/4 - 11 1/2

ADAPTERS

1700

M-JIC / FLANGE STRAIGHT (CODE 61)

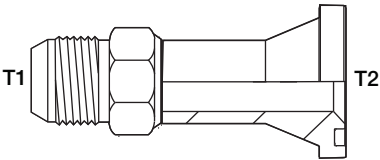
	PART NUMBER	T1	T2
	1700-0808	3/4 - 16	1/2
1700-0812	3/4 - 16	3/4	
1700-1212	1 1/16 - 12	3/4	
1700-1216	1 1/16 - 12	1	
1700-1220	1 1/16 - 12	1 1/4	
1700-1612	1 5/16 - 12	3/4	
1700-1616	1 5/16 - 12	1	
1700-1620	1 5/16 - 12	1 1/4	
1700-1624	1 5/16 - 12	1 1/2	
1700-2016	1 5/8 - 12	1	
1700-2020	1 5/8 - 12	1 1/4	
1700-2024	1 5/8 - 12	1 1/2	
1700-2032	1 5/8 - 12	2	
1700-2420	1 7/8 - 12	1 1/4	
1700-2424	1 7/8 - 12	1 1/2	
1700-2432	1 7/8 - 12	2	
1700-3224	2 1/2 - 12	1 1/2	
1700-3232	2 1/2 - 12	2	

1703

45° M-JIC / FLANGE (CODE 61)

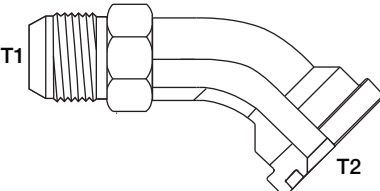
	PART NUMBER	T1	T2
	1703-0808	3/4 - 16	1/2
1703-0812	3/4 - 16	3/4	
1703-1212	1 1/16 - 12	3/4	
1703-1216	1 1/16 - 12	1	
1703-1220	1 1/16 - 12	1 1/4	
1703-1612	1 5/16 - 12	3/4	
1703-1616	1 5/16 - 12	1	
1703-1620	1 5/16 - 12	1 1/4	
1703-1624	1 5/16 - 12	1 1/2	
1703-2012	1 5/8 - 12	3/4	
1703-2016	1 5/8 - 12	1	
1703-2020	1 5/8 - 12	1 1/4	
1703-2024	1 5/8 - 12	1 1/2	
1703-2420	1 7/8 - 12	1 1/4	
1703-2424	1 7/8 - 12	1 1/2	
1703-2432	1 7/8 - 12	2	
1703-3232	2 1/2 - 12	2	

ADAPTERS

1703FG FORGED 45° M-JIC / FLANGE (CODE 61)

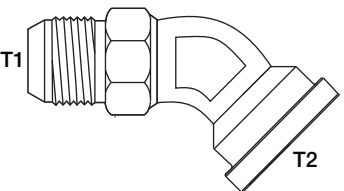
	PART NUMBER	T1	T2
	1703FG-1212	1 ¹ / ₁₆ - 12	3/4
	1703FG-1616	1 ⁵ / ₁₆ - 12	1
	1703FG-2020	1 ⁵ / ₈ - 12	1 ¹ / ₄
	1703FG-2424	1 ⁷ / ₈ - 12	1 ¹ / ₂
	1703FG-3232	2 ¹ / ₂ - 12	2

1704 90° M-JIC / FLANGE (CODE 61)

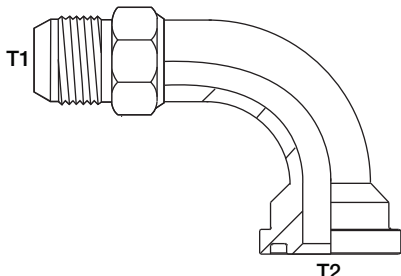
	PART NUMBER	T1	T2
	1704-0808	3/4 - 16	1/2
	1704-0812	3/4 - 16	3/4
	1704-1212	1 ¹ / ₁₆ - 12	3/4
	1704-1216	1 ¹ / ₁₆ - 12	1
	1704-1220	1 ¹ / ₁₆ - 12	1 ¹ / ₄
	1704-1612	1 ⁵ / ₁₆ - 12	3/4
	1704-1616	1 ⁵ / ₁₆ - 12	1
	1704-1620	1 ⁵ / ₁₆ - 12	1 ¹ / ₄
	1704-1624	1 ⁵ / ₁₆ - 12	1 ¹ / ₂
	1704-2016	1 ⁵ / ₈ - 12	1
	1704-2020	1 ⁵ / ₈ - 12	1 ¹ / ₄
	1704-2024	1 ⁵ / ₈ - 12	1 ¹ / ₂
	1704-2420	1 ⁷ / ₈ - 12	1 ¹ / ₄
	1704-2424	1 ⁷ / ₈ - 12	1 ¹ / ₂
	1704-2432	1 ⁷ / ₈ - 12	2
	1704-3224	2 ¹ / ₂ - 12	1 ¹ / ₂
	1704-3232	2 ¹ / ₂ - 12	2

1704FG FORGED 90° M-JIC / FLANGE (CODE 61)

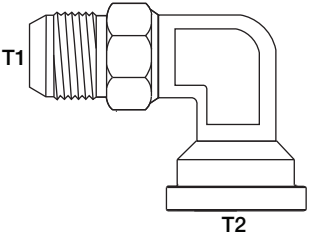
	PART NUMBER	T1	T2
	1704-0812FG	3/4 - 16	3/4
	1704-1212FG	1 ¹ / ₁₆ - 12	3/4
	1704-1216FG	1 ¹ / ₁₆ - 12	1
	1704-1612FG	1 ⁵ / ₁₆ - 12	3/4
	1704-1616FG	1 ⁵ / ₁₆ - 12	1
	1704-1620FG	1 ⁵ / ₁₆ - 12	1 ¹ / ₄
	1704-2016FG	1 ⁵ / ₈ - 12	1
	1704-2020FG	1 ⁵ / ₈ - 12	1 ¹ / ₄
	1704-2024FG	1 ⁵ / ₈ - 12	1 ¹ / ₂
	1704-2424FG	1 ⁷ / ₈ - 12	1 ¹ / ₂
	1704-2432FG	1 ⁷ / ₈ - 12	2
	1704-3224FG	2 ¹ / ₂ - 12	1 ¹ / ₂
	1704-3232FG	2 ¹ / ₂ - 12	2

ADAPTERS

1724 FLANGE PLUG (CODE 61)

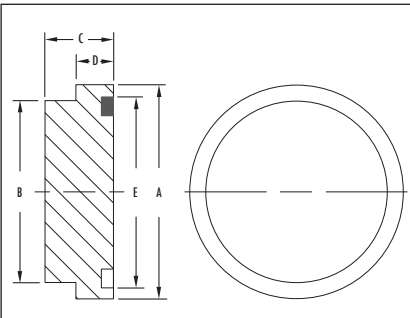
	PART NUMBER	A	B	D
		1724-08	1.188	.924
	1724-12	1.500	1.234	.265
	1724-16	1.750	1.484	.315
	1724-20	2.000	1.684	.315
	1724-24	2.375	1.964	.315
	1724-32	2.810	2.434	.375
	1724-40	3.312	2.904	.375
	1724-48	4.000	3.534	.375
	1724-56			

1800 M-JIC / FLANGE STRAIGHT (CODE 62)

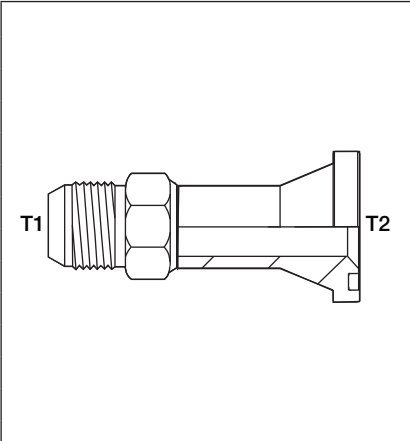
	PART NUMBER	T1	T2
		1800-0808	3/4 - 16
	1800-1212	1 1/16 - 12	3/4
	1800-1216	1 1/16 - 12	1
	1800-1612	1 5/16 - 12	3/4
	1800-1616	1 5/16 - 12	1
	1800-1620	1 5/16 - 12	1 1/4
	1800-1624	1 5/16 - 12	1 1/2
	1800-2016	1 5/8 - 12	1
	1800-2020	1 5/8 - 12	1 1/4
	1800-2024	1 5/8 - 12	1 1/2
	1800-2420	1 7/8 - 12	1 1/4
	1800-2424	1 7/8 - 12	1 1/2
	1800-3232	2 1/2 - 12	2

1803 45° M-JIC / FLANGE (CODE 62)

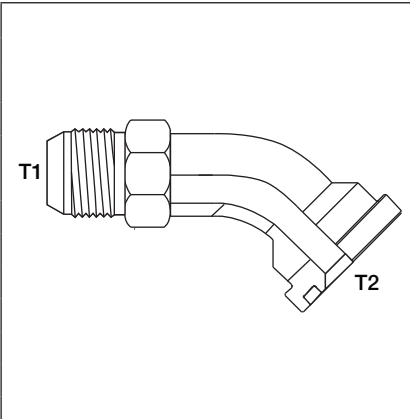
	PART NUMBER	T1	T2
		1803-0808	3/4 - 16
	1803-1212	1 1/16 - 12	3/4
	1803-1216	1 1/16 - 12	1
	1803-1612	1 5/16 - 12	3/4
	1803-1616	1 5/16 - 12	1
	1803-1620	1 5/16 - 12	1 1/4
	1803-1624	1 5/16 - 12	1 1/2
	1803-2016	1 5/8 - 12	1
	1803-2020	1 5/8 - 12	1 1/4
	1803-2024	1 5/8 - 12	1 1/2
	1803-2424	1 7/8 - 12	1 1/2
	1803-3232	2 1/2 - 12	2

1803FG FORGED 45° M-JIC / FLANGE (CODE 62)

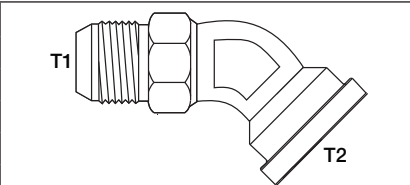
	PART NUMBER	T1	T2
		1803-1212FG	1 1/16 - 12
	1803-1616FG	1 5/16 - 12	1
	1803-2020FG	1 5/8 - 12	1 1/4
	1803-2424FG	1 7/8 - 12	1 1/2
	1803-3232FG	2 1/2 - 12	2

ADAPTERS

1804 90° M-JIC / FLANGE (CODE 62)

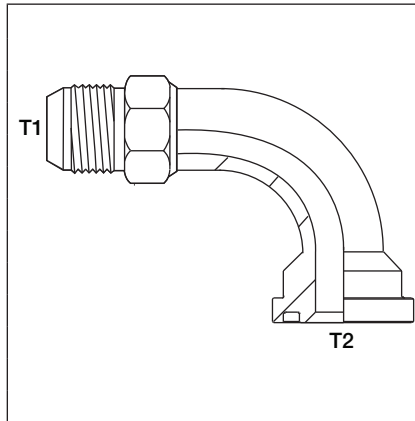

PART NUMBER	T1	T2
1804-0808	3/4 - 16	1/2
1804-1212	1 1/16 - 12	3/4
1804-1616	1 5/16 - 12	1
1804-1620	1 5/16 - 12	1 1/4
1804-1624	1 5/16 - 12	1 1/2
1804-2016	1 5/8 - 12	1
1804-2020	1 5/8 - 12	1 1/4
1804-2024	1 5/8 - 12	1 1/2
1804-2416	1 7/8 - 12	1
1804-2420	1 7/8 - 12	1 1/4
1804-2424	1 7/8 - 12	1 1/2
1804-3232	2 1/2 - 12	2

1804FG FORGED 90° M-JIC / FLANGE (CODE 62)

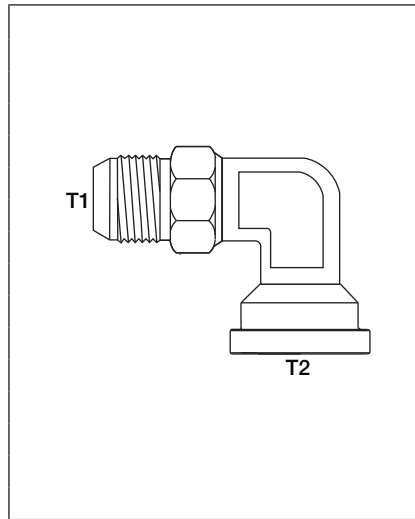

PART NUMBER	T1	T2
1804-0808FG	3/4 - 16	1/2
1804-0812FG	3/4 - 16	3/4
1804-1212FG	1 1/16 - 12	3/4
1804-1216FG	1 1/16 - 12	1
1804-1612FG	1 5/16 - 12	3/4
1804-1616FG	1 5/16 - 12	1
1804-1620FG	1 5/16 - 12	1 1/4
1804-2016FG	1 5/8 - 12	1
1804-2020FG	1 5/8 - 12	1 1/4
1804-2024FG	1 5/8 - 12	1 1/2
1804-2420FG	1 7/8 - 12	1 1/4
1804-2424FG	1 7/8 - 12	1 1/2
1804-2432FG	1 7/8 - 12	2
1804-3224FG	2 1/2 - 12	1 1/2
1804-3232FG	2 1/2 - 12	2

1824 FLANGE PLUG (CODE 62)

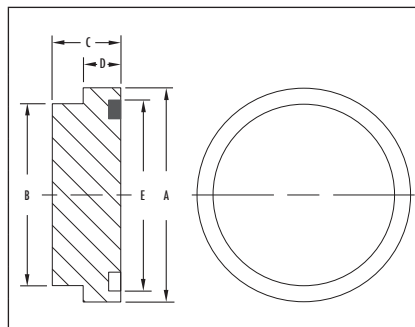

PART NUMBER	A	B	D
1824-12	1.625	1.234	.345
1824-16	1.875	1.484	.375
1824-20	2.125	1.704	.405
1824-24	2.500	1.984	.495
1824-32	3.125	2.604	.495

ADAPTERS

1901 SPLIT FLANGE KIT (CODE 61)

	PART NUMBER	SIZE
	1901-08-K	1/2
	1901-12-K	3/4
	1901-16-K	1
	1901-20-K	1 1/4
	1901-24-K	1 1/2
	1901-32-K	2
	1901-40-K	2 1/2
	1901-48-K	3
	1901-56-K	3 1/2
1901-64-K	4	

1902 SPLIT FLANGE KIT (CODE 62)

	PART NUMBER	SIZE
	1902-08-K	1/2
	1902-12-K	3/4
	1902-16-K	1
	1902-20-K	1 1/4
	1902-24-K	1 1/2
	1902-32-K	2

1903 CATERPILLAR® SPLIT FLANGE KIT (CODE 62)

	PART NUMBER	SIZE
	1903-08-K	1/2
	1903-12-K	3/4
	1903-16-K	1
	1903-20-K	1 1/4
	1903-24-K	1 1/2
	1903-32-K	2

1927-61 F-NPT / FLANGE KIT (CODE 61)

	PART NUMBER	T1	T2
	1927-1212-K	3/4 - 14	3/4
	1927-1616-K	1 - 11 1/2	1
	1927-2020-K	1 1/4 - 11 1/2	1 1/4
	1927-2424-K	1 1/2 - 11 1/2	1 1/2
	1927-3232-K	2 - 11 1/2	2
	1927-4040-K	2 1/2 - 8	2 1/2
	1927-4848-K	3 - 8	3

ADAPTERS

2403 M-JIC / M-JIC STRAIGHT

	PART NUMBER	T1	T2
		2403-0202	5/16 - 24
2403-0303		3/8 - 24	3/8 - 24
2403-0402		7/16 - 20	5/16 - 24
2403-0404		7/16 - 20	7/16 - 20
2403-0505		1/2 - 20	1/2 - 20
2403-0604		9/16 - 18	7/16 - 20
2403-0606		9/16 - 18	9/16 - 18
2403-0804		3/4 - 16	7/16 - 20
2403-0806		3/4 - 16	9/16 - 18
2403-0808		3/4 - 16	3/4 - 16
2403-1004		7/8 - 14	7/16 - 20
2403-1006		7/8 - 14	9/16 - 18
2403-1008		7/8 - 14	3/4 - 16
2403-1010		7/8 - 14	7/8 - 14
2403-1208		1 1/16 - 12	3/4 - 16
2403-1210		1 1/16 - 12	7/8 - 14
2403-1212		1 1/16 - 12	1 1/16 - 12
2403-1414		1 3/16 - 12	1 3/16 - 12
2403-1608		1 5/16 - 12	3/4 - 16
2403-1610		1 5/16 - 12	7/8 - 14
2403-1612		1 5/16 - 12	1 1/16 - 12
2403-1616		1 5/16 - 12	1 5/16 - 12
2403-2012		1 5/8 - 12	1 1/16 - 12
2403-2016		1 5/8 - 12	1 5/16 - 12
2403-2020		1 5/8 - 12	1 5/8 - 12
2403-2412		1 7/8 - 12	1 1/16 - 12
2403-2416		1 7/8 - 12	1 5/16 - 12
2403-2420		1 7/8 - 12	1 5/8 - 12
2403-2424		1 7/8 - 12	1 7/8 - 12
2403-3232		2 1/2 - 12	2 1/2 - 12

2403LH M-JIC / M-JIC - LARGE HEX STRAIGHT

	PART NUMBER	T1	T2
	2403LH-0404	7/16 - 20	7/16 - 20
	2403LH-0505	1/2 - 20	1/2 - 20
	2403LH-0606	9/16 - 18	9/16 - 18
	2403LH-0808	3/4 - 16	3/4 - 16
	2403LH-1010	7/8 - 14	7/8 - 14
	2403LH-1212	1 1/16 - 12	1 1/16 - 12
	2403LH-1616	1 5/16 - 12	1 5/16 - 12
	2403LH-2020	1 5/8 - 12	1 5/8 - 12
	2403LH-2424	1 7/8 - 12	1 7/8 - 12

ADAPTERS

2404

M-JIC / M-NPT STRAIGHT

SAE# 070102

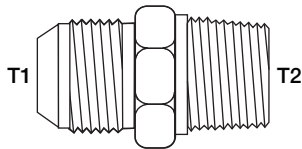

PART NUMBER	T1	T2
2404-0202	5/16 - 24	1/8 - 27
2404-0204	5/16 - 24	1/4 - 18
2404-0302	3/8 - 24	1/8 - 27
2404-0402	7/16 - 20	1/8 - 27
2404-0404	7/16 - 20	1/4 - 18
2404-0406	7/16 - 20	3/8 - 18
2404-0408	7/16 - 20	1/2 - 14
2404-0502	1/2 - 20	1/8 - 27
2404-0504	1/2 - 20	1/4 - 18
2404-0506	1/2 - 20	3/8 - 18
2404-0602	9/16 - 18	1/8 - 27
2404-0604	9/16 - 18	1/4 - 18
2404-0606	9/16 - 18	3/8 - 18
2404-0608	9/16 - 18	1/2 - 14
2404-0612	9/16 - 18	3/4 - 14
2404-0802	3/4 - 16	1/8 - 27
2404-0804	3/4 - 16	1/4 - 18
2404-0806	3/4 - 16	3/8 - 18
2404-0808	3/4 - 16	1/2 - 14
2404-0812	3/4 - 16	3/4 - 14
2404-0816	3/4 - 16	1 - 11 1/2
2404-1004	7/8 - 14	1/4 - 18
2404-1006	7/8 - 14	3/8 - 18
2404-1008	7/8 - 14	1/2 - 14
2404-1012	7/8 - 14	3/4 - 14
2404-1206	1 1/16 - 12	3/8 - 18
2404-1208	1 1/16 - 12	1/2 - 14
2404-1212	1 1/16 - 12	3/4 - 14
2404-1216	1 1/16 - 12	1 - 11 1/2
2404-1220	1 1/16 - 12	1 1/4 - 11 1/2
2404-1224	1 1/16 - 12	1 1/2 - 11 1/2
2404-1408	1 3/16 - 12	1/2 - 14
2404-1412	1 3/16 - 12	3/4 - 14
2404-1608	1 5/16 - 12	1/2 - 14
2404-1612	1 5/16 - 12	3/4 - 14
2404-1616	1 5/16 - 12	1 - 11 1/2
2404-1620	1 5/16 - 12	1 1/4 - 11 1/2
2404-1624	1 5/16 - 12	1 1/2 - 11 1/2
2404-2012	1 5/8 - 12	3/4 - 14
2404-2016	1 5/8 - 12	1 - 11 1/2
2404-2020	1 5/8 - 12	1 1/4 - 11 1/2
2404-2024	1 5/8 - 12	1 1/2 - 11 1/2
2404-2032	1 5/8 - 12	2 - 11 1/2
2404-2416	1 7/8 - 12	1 - 11 1/2
2404-2420	1 7/8 - 12	1 1/4 - 11 1/2
2404-2424	1 7/8 - 12	1 1/2 - 11 1/2
2404-2432	1 7/8 - 12	2 - 11 1/2
2404-3220	2 1/2 - 12	1 1/4 - 11 1/2
2404-3224	2 1/2 - 12	1 1/2 - 11 1/2
2404-3232	2 1/2 - 12	2 - 11 1/2

ADAPTERS

2404L M-JIC / M-NPT LONG STRAIGHT

	PART NUMBER	T1	T2
		2404L-0402	7/16 - 20
2404L-0404		7/16 - 20	1/4 - 18
2404L-0502		1/2 - 20	1/8 - 27
2404L-0504		1/2 - 20	1/4 - 18
2404L-0602		9/16 - 18	1/8 - 27
2404L-0604		9/16 - 18	1/4 - 18
2404L-0606		9/16 - 18	3/8 - 18
2404L-0608		9/16 - 18	1/2 - 14
2404L-0804		3/4 - 16	1/4 - 18
2404L-0806		3/4 - 16	3/8 - 18
2404L-0808		3/4 - 16	1/2 - 14
2404L-1008		7/8 - 14	1/2 - 14
2404L-1212		1 1/16 - 12	3/4 - 14
2404L-1612		1 5/16 - 12	3/4 - 14
2404L-1616		1 5/16 - 12	1 - 11 1/2
2404L-2020		1 5/8 - 12	1 1/4 - 11 1/2
2404L-2424		1 7/8 - 12	1 1/2 - 11 1/2
2404L-3232		2 1/2 - 12	2 - 11 1/2

2404LL M-JIC / M-NPT EXTRA LONG STRAIGHT

	PART NUMBER	T1	T2
		2404LL-0402	7/16 - 20
2404LL-0404		7/16 - 20	1/4 - 18
2404LL-0502		1/2 - 20	1/8 - 27
2404LL-0604		9/16 - 18	1/4 - 18
2404LL-0606		9/16 - 18	3/8 - 18
2404LL-0806		3/4 - 16	3/8 - 18
2404LL-0808		3/4 - 16	1/2 - 14
2404LL-1008		7/8 - 14	1/2 - 14
2404LL-1212		1 1/16 - 12	3/4 - 14
2404LL-1616		1 5/16 - 12	1 - 11 1/2

ADAPTERS

2405

M-JIC / F-NPT STRAIGHT

SAE# 070103

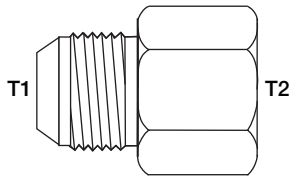

PART NUMBER	T1	T2
2405-0202	5/16 - 24	1/8 - 27
2405-0302	3/8 - 24	1/8 - 27
2405-0402	7/16 - 20	1/8 - 27
2405-0404	7/16 - 20	1/4 - 18
2405-0406	7/16 - 20	3/8 - 18
2405-0408	7/16 - 20	1/2 - 14
2405-0502	1/2 - 20	1/8 - 27
2405-0504	1/2 - 20	1/4 - 18
2405-0602	9/16 - 18	1/8 - 27
2405-0604	9/16 - 18	1/4 - 18
2405-0606	9/16 - 18	3/8 - 18
2405-0608	9/16 - 18	1/2 - 14
2405-0804	3/4 - 16	1/4 - 18
2405-0806	3/4 - 16	3/8 - 18
2405-0808	3/4 - 16	1/2 - 14
2405-0812	3/4 - 16	3/4 - 14
2405-1006	7/8 - 14	3/8 - 18
2405-1008	7/8 - 14	1/2 - 14
2405-1012	7/8 - 14	3/4 - 14
2405-1016	7/8 - 14	1 - 11 1/2
2405-1208	1 1/16 - 12	1/2 - 14
2405-1212	1 1/16 - 12	3/4 - 14
2405-1216	1 1/16 - 12	1 - 11 1/2
2405-1412	1 3/16 - 12	3/4 - 14
2405-1612	1 5/16 - 12	3/4 - 14
2405-1616	1 5/16 - 12	1 - 11 1/2
2405-1620	1 5/8 - 12	1 1/4 - 11 1/2
2405-2016	1 5/8 - 12	1 - 11 1/2
2405-2020	1 5/8 - 12	1 1/4 - 11 1/2
2405-2024	1 5/8 - 12	1 1/2 - 11 1/2
2405-2420	1 7/8 - 12	1 1/4 - 11 1/2
2405-2424	1 7/8 - 12	1 1/2 - 11 1/2
2405-3232	2 1/2 - 12	2 - 11 1/2

ADAPTERS

2406

*F-JIC / M-JIC (*REDUCING MAY BE SUPPLIED WITH 2 PIECE ADAPTER)

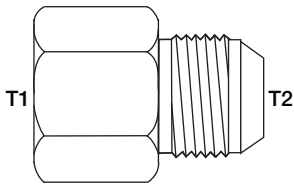

PART NUMBER	T1	T2
2406-0402	7/16 - 20	5/16 - 24
2406-0406	7/16 - 20	9/16 - 18
2406-0408	7/16 - 20	3/4 - 16
2406-0604	9/16 - 18	7/16 - 20
2406-0608	9/16 - 18	3/4 - 16
2406-0804	3/4 - 16	7/16 - 20
2406-0806	3/4 - 16	9/16 - 18
2406-0810	3/4 - 16	7/8 - 14
2406-0812	3/4 - 16	1 1/16 - 12
2406-1004	7/8 - 14	7/16 - 20
2406-1006	7/8 - 14	9/16 - 18
2406-1008	7/8 - 14	3/4 - 16
2406-1012	7/8 - 14	1 1/16 - 12
2406-1204	1 1/16 - 12	7/16 - 20
2406-1206	1 1/16 - 12	9/16 - 18
2406-1208	1 1/16 - 12	3/4 - 16
2406-1210	1 1/16 - 12	7/8 - 14
2406-1216	1 1/16 - 12	1 5/16 - 12
2406-1406	1 3/16 - 12	9/16 - 18
2406-1408	1 3/16 - 12	3/4 - 16
2406-1410	1 3/16 - 12	7/8 - 14
2406-1412	1 3/16 - 12	1 1/16 - 12
2406-1604	1 5/16 - 12	7/16 - 20
2406-1606	1 5/16 - 12	9/16 - 18
2406-1608	1 5/16 - 12	3/4 - 16
2406-1610	1 5/16 - 12	7/8 - 14
2406-1612	1 5/16 - 12	1 1/16 - 12
2406-1620	1 5/16 - 12	1 5/8 - 12
2406-1624	1 5/16 - 12	1 7/8 - 12
2406-2012	1 5/8 - 12	1 1/16 - 12
2406-2016	1 5/8 - 12	1 5/16 - 12
2406-2024	1 5/8 - 12	1 7/8 - 12
2406-2416	1 7/8 - 12	1 5/16 - 12
2406-2420	1 7/8 - 12	1 5/8 - 12
2406-2432	1 7/8 - 12	2 1/2 - 12
2406-3224	2 1/2 - 12	1 7/8 - 12

ADAPTERS

2408

JIC PLUG

SAE# 070109

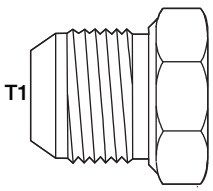
	PART NUMBER	T1
	2408-02	5/16 - 24
2408-03	3/8 - 24	
2408-04	7/16 - 20	
2408-05	1/2 - 20	
2408-06	9/16 - 18	
2408-08	3/4 - 16	
2408-10	7/8 - 14	
2408-12	1 1/16 - 12	
2408-14	1 3/16 - 12	
2408-16	1 5/16 - 12	
2408-20	1 5/8 - 12	
2408-24	1 7/8 - 12	
2408-32	2 1/2 - 12	

2500

90° M-JIC / M-JIC

SAE# 070201

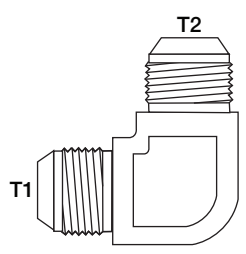
	PART NUMBER	T1	T2
	2500-0202	5/16 - 24	5/16 - 24
2500-0303	3/8 - 24	3/8 - 24	
2500-0404	7/16 - 20	7/16 - 20	
2500-0504	1/2 - 20	7/16 - 20	
2500-0505	1/2 - 20	1/2 - 20	
2500-0604	9/16 - 18	7/16 - 20	
2500-0605	9/16 - 18	1/2 - 20	
2500-0606	9/16 - 18	9/16 - 18	
2500-0806	3/4 - 16	9/16 - 18	
2500-0808	3/4 - 16	3/4 - 16	
2500-1008	7/8 - 14	3/4 - 16	
2500-1010	7/8 - 14	7/8 - 14	
2500-1208	1 1/16 - 12	3/4 - 16	
2500-1210	1 1/16 - 12	7/8 - 14	
2500-1212	1 1/16 - 12	1 1/16 - 12	
2500-1414	1 3/16 - 12	1 3/16 - 12	
2500-1612	1 5/16 - 12	1 1/16 - 12	
2500-1616	1 5/16 - 12	1 5/16 - 12	
2500-2020	1 5/8 - 12	1 5/8 - 12	
2500-2424	1 7/8 - 12	1 7/8 - 12	
2500-3232	2 1/2 - 12	2 1/2 - 12	

ADAPTERS

2501

90° M-JIC / M-NPT

SAE# 51504

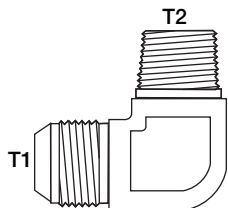

PART NUMBER	T1	T2
2501-0202	5/16 - 24	1/8 - 27
2501-0204	5/16 - 24	1/4 - 18
2501-0302	3/8 - 24	1/8 - 27
2501-0402	7/16 - 20	1/8 - 27
2501-0404	7/16 - 20	1/4 - 18
2501-0406	7/16 - 20	3/8 - 18
2501-0408	7/16 - 20	1/2 - 14
2501-0412	7/16 - 20	3/4 - 14
2501-0502	1/2 - 20	1/8 - 27
2501-0504	1/2 - 20	1/4 - 18
2501-0506	1/2 - 20	3/8 - 18
2501-0508	1/2 - 20	1/2 - 14
2501-0602	9/16 - 18	1/8 - 27
2501-0604	9/16 - 18	1/4 - 18
2501-0606	9/16 - 18	3/8 - 18
2501-0608	9/16 - 18	1/2 - 14
2501-0612	9/16 - 18	3/4 - 14
2501-0802	3/4 - 16	1/8 - 27
2501-0804	3/4 - 16	1/4 - 18
2501-0806	3/4 - 16	3/8 - 18
2501-0808	3/4 - 16	1/2 - 14
2501-0812	3/4 - 16	3/4 - 14
2501-0816	3/4 - 16	1 - 11 1/2
2501-1006	7/8 - 14	3/8 - 18
2501-1008	7/8 - 14	1/2 - 14
2501-1012	7/8 - 14	3/4 - 14
2501-1016	7/8 - 14	1/4 - 18
2501-1206	1 1/16 - 12	3/8 - 18
2501-1208	1 1/16 - 12	1/2 - 14
2501-1212	1 1/16 - 12	3/4 - 14
2501-1216	1 1/16 - 12	1 - 11 1/2
2501-1412	1 3/16 - 12	3/4 - 14
2501-1608	1 5/16 - 12	1/2 - 14
2501-1612	1 5/16 - 12	3/4 - 14
2501-1616	1 5/16 - 12	1 - 11 1/2
2501-1620	1 5/16 - 12	1 1/4 - 11 1/2
2501-1624	1 5/16 - 12	1 1/2 - 11 1/2
2501-2012	1 5/8 - 12	3/4 - 14
2501-2016	1 5/8 - 12	1 - 11 1/2
2501-2020	1 5/8 - 12	1 1/4 - 11 1/2
2501-2024	1 5/8 - 12	1 1/2 - 11 1/2
2501-2416	1 7/8 - 12	1 - 11 1/2
2501-2420	1 7/8 - 12	1 1/4 - 11 1/2
2501-2424	1 7/8 - 12	1 1/2 - 11 1/2
2501-2432	1 7/8 - 12	2 - 11 1/2
2501-3224	2 1/2 - 12	1 1/2 - 11 1/2
2501-3232	2 1/2 - 12	2 - 11 1/2

ADAPTERS

2501L 90° M-JIC / M-NPT LONG

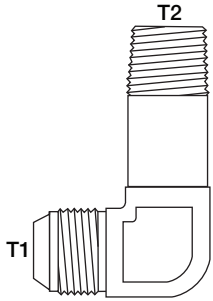

PART NUMBER	T1	T2
2501L-0402	7/16 - 20	1/8 - 27
2501L-0404	7/16 - 20	1/4 - 18
2501L-0502	1/2 - 20	1/8 - 27
2501L-0504	1/2 - 20	1/4 - 18
2501L-0602	9/16 - 18	1/8 - 27
2501L-0604	9/16 - 18	1/4 - 18
2501L-0606	9/16 - 18	3/8 - 18
2501L-0608	9/16 - 18	1/2 - 14
2501L-0804	3/4 - 16	1/4 - 18
2501L-0806	3/4 - 16	3/8 - 18
2501L-0808	3/4 - 16	1/2 - 14
2501L-0812	3/4 - 16	3/4 - 14
2501L-1008	7/8 - 14	1/2 - 14
2501L-1212	1 1/16 - 12	3/4 - 14
2501L-1216	1 1/16 - 12	1 - 11 1/2
2501L-1412	1 3/16 - 12	3/4 - 14
2501L-1616	1 5/16 - 12	1 - 11 1/2
2501L-2020	1 5/8 - 12	1 1/4 - 11 1/2
2501L-2424	1 7/8 - 12	1 1/2 - 11 1/2

2501LL 90° M-JIC / M-NPT EXTRA LONG

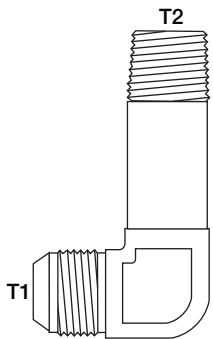

PART NUMBER	T1	T2
2501LL-0402	7/16 - 20	1/8 - 27
2501LL-0404	7/16 - 20	1/4 - 18
2501LL-0406	7/16 - 20	3/8 - 18
2501LL-0502	1/2 - 20	1/8 - 27
2501LL-0504	1/2 - 20	1/4 - 18
2501LL-0604	9/16 - 18	1/4 - 18
2501LL-0606	9/16 - 18	3/8 - 18
2501LL-0608	9/16 - 18	1/2 - 14
2501LL-0806	3/4 - 16	3/8 - 18
2501LL-0808	3/4 - 16	1/2 - 14
2501LL-1008	7/8 - 14	1/2 - 14
2501LL-1208	1 1/16 - 12	1/2 - 14
2501LL-1212	1 1/16 - 12	3/4 - 14
2501LL-1412	1 3/16 - 12	3/4 - 14
2501LL-1616	1 5/16 - 12	1 - 11 1/2
2501LL-2020	1 5/8 - 12	1 1/4 - 11 1/2

ADAPTERS

2501LLL

90° M-JIC / M-NPT EXTRA EXTRA LONG

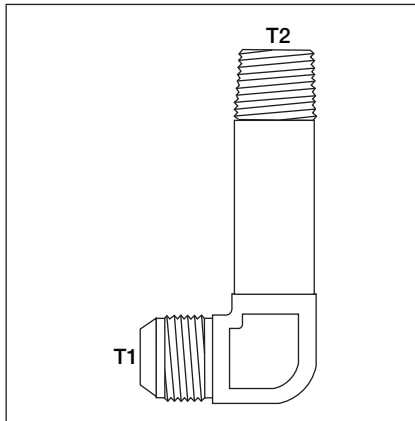

PART NUMBER	T1	T2
2501LLL-0402	7/16 - 20	1/8 - 27
2501LLL-0404	7/16 - 20	1/4 - 18
2501LLL-0502	1/2 - 20	1/8 - 27
2501LLL-0604	9/16 - 18	1/4 - 18
2501LLL-0606	9/16 - 18	3/8 - 18
2501LLL-0806	3/4 - 16	3/8 - 18
2501LLL-0808	3/4 - 16	1/2 - 14
2501LLL-1008	7/8 - 14	1/2 - 14
2501LLL-1212	1 1/16 - 12	3/4 - 14
2501LLL-1616	1 5/16 - 12	1 - 11 1/2

2502

90° M-JIC / F-NPT

SAE# 070203

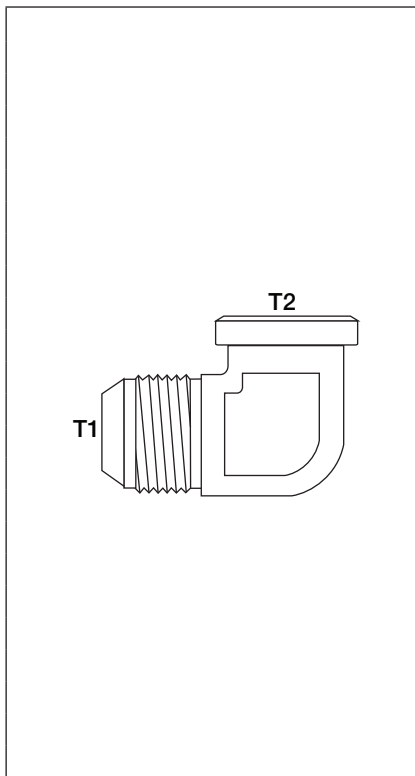

PART NUMBER	T1	T2
2502-0202	5/16 - 24	1/8 - 27
2502-0302	3/8 - 24	1/8 - 27
2502-0402	7/16 - 20	1/8 - 27
2502-0404	7/16 - 20	1/4 - 18
2502-0406	7/16 - 20	3/8 - 18
2502-0502	1/2 - 20	1/8 - 27
2502-0504	1/2 - 20	1/4 - 18
2502-0602	9/16 - 18	1/8 - 27
2502-0604	9/16 - 18	1/4 - 18
2502-0606	9/16 - 18	3/8 - 18
2502-0608	9/16 - 18	1/2 - 14
2502-0804	3/4 - 16	1/4 - 18
2502-0806	3/4 - 16	3/8 - 18
2502-0808	3/4 - 16	1/2 - 14
2502-1008	7/8 - 14	1/2 - 14
2502-1208	1 1/16 - 12	1/2 - 14
2502-1212	1 1/16 - 12	3/4 - 14
2502-1412	1 3/16 - 12	3/4 - 14
2502-1612	1 5/16 - 12	3/4 - 14
2502-1616	1 5/16 - 12	1 - 11 1/2
2502-2020	1 5/8 - 12	1 1/4 - 11 1/2
2502-2424	1 7/8 - 12	1 1/2 - 11 1/2
2502-3232	2 1/2 - 12	2 - 11 1/2

ADAPTERS

2503

45° M-JIC / M-NPT

SAE# 070302

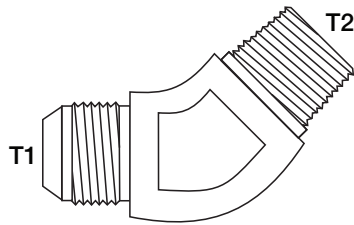

PART NUMBER	T1	T2
2503-0202	5/16 - 24	1/8 - 27
2503-0302	3/8 - 24	1/8 - 27
2503-0402	7/16 - 20	1/8 - 27
2503-0404	7/16 - 20	1/4 - 18
2503-0406	7/16 - 20	3/8 - 18
2503-0408	7/16 - 20	1/2 - 14
2503-0502	1/2 - 20	1/8 - 27
2503-0504	1/2 - 20	1/4 - 18
2503-0602	9/16 - 18	1/8 - 27
2503-0604	9/16 - 18	1/4 - 18
2503-0606	9/16 - 18	3/8 - 18
2503-0608	9/16 - 18	1/2 - 14
2503-0612	9/16 - 18	3/4 - 14
2503-0804	3/4 - 16	1/4 - 18
2503-0806	3/4 - 16	3/8 - 18
2503-0808	3/4 - 16	1/2 - 14
2503-0812	3/4 - 16	3/4 - 14
2503-1006	7/8 - 14	3/8 - 18
2503-1008	7/8 - 14	1/2 - 14
2503-1012	7/8 - 14	3/4 - 14
2503-1208	1 1/16 - 12	1/2 - 14
2503-1212	1 1/16 - 12	3/4 - 14
2503-1216	1 1/16 - 12	1 - 11 1/2
2503-1412	1 3/16 - 12	3/4 - 14
2503-1608	1 5/16 - 12	1/2 - 14
2503-1612	1 5/16 - 12	3/4 - 14
2503-1616	1 5/16 - 12	1 - 11 1/2
2503-1620	1 5/16 - 12	1 1/4 - 11 1/2
2503-2016	1 5/8 - 12	1 - 11 1/2
2503-2020	1 5/8 - 12	1 1/4 - 11 1/2
2503-2024	1 5/8 - 12	1 1/2 - 11 1/2
2503-2424	1 7/8 - 12	1 1/2 - 11 1/2
2503-3232	2 1/2 - 12	2 - 11 1/2

2504

45° M-JIC / M-JIC

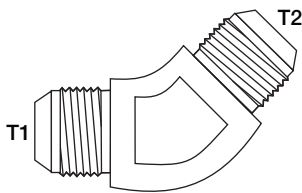

PART NUMBER	T1	T2
2504-0404	7/16 - 20	7/16 - 20
2504-0606	9/16 - 18	9/16 - 18
2504-0808	3/4 - 16	3/4 - 16
2504-1010	7/8 - 14	7/8 - 14
2504-1212	1 1/16 - 12	1 1/16 - 12
2504-1616	1 5/16 - 12	1 5/16 - 12

ADAPTERS

2505 45° M-JIC / F-NPT

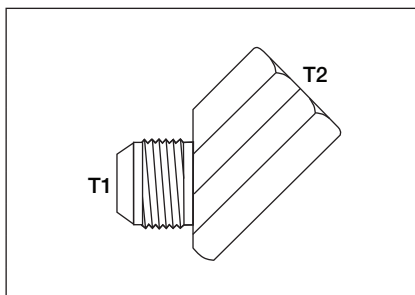

PART NUMBER	T1	T2
2505-0404	7/16 - 20	1/4 - 18
2505-0604	9/16 - 18	1/4 - 18
2505-0606	9/16 - 18	3/8 - 18
2505-0806	3/4 - 16	3/8 - 18
2505-0808	3/4 - 16	1/2 - 14
2505-1008	7/8 - 14	1/2 - 14
2505-1212	1 1/16 - 12	3/4 - 14
2505-1616	1 5/16 - 12	1 - 11 1/2

2601 BRANCH TEE M-JIC / M-JIC / M-NPT

SAE# 070425

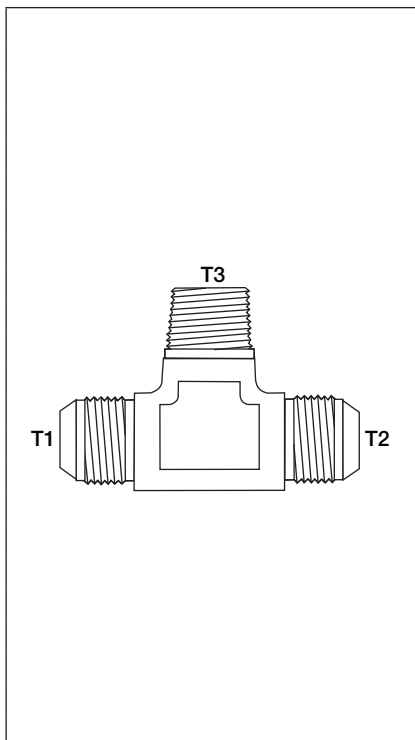

PART NUMBER	T1	T2	T3
2601-030302	3/8 - 24	3/8 - 24	1/8 - 27
2601-040402	7/16 - 20	7/16 - 20	1/8 - 27
2601-040404	7/16 - 20	7/16 - 20	1/4 - 18
2601-040406	7/16 - 20	7/16 - 20	3/8 - 18
2601-050502	1/2 - 20	1/2 - 20	1/8 - 27
2601-050504	1/2 - 20	1/2 - 20	1/4 - 18
2601-060604	9/16 - 18	9/16 - 18	1/4 - 18
2601-060606	9/16 - 18	9/16 - 18	3/8 - 18
2601-060608	9/16 - 18	9/16 - 18	1/2 - 14
2601-080804	3/4 - 16	3/4 - 16	1/4 - 18
2601-080806	3/4 - 16	3/4 - 16	3/8 - 18
2601-080808	3/4 - 16	3/4 - 16	1/2 - 14
2601-101006	7/8 - 14	7/8 - 14	3/8 - 18
2601-101008	7/8 - 14	7/8 - 14	1/2 - 14
2601-121208	1 1/16 - 12	1 1/16 - 12	1/2 - 14
2601-121212	1 1/16 - 12	1 1/16 - 12	3/4 - 14
2601-141412	1 3/16 - 12	1 3/16 - 12	3/4 - 14
2601-161612	1 5/16 - 12	1 5/16 - 12	3/4 - 14
2601-161616	1 5/16 - 12	1 5/16 - 12	1 - 11 1/2
2601-202020	1 5/8 - 12	1 5/8 - 12	1 1/4 - 11 1/2
2601-242424	1 7/8 - 12	1 7/8 - 12	1 1/2 - 11 1/2
2601-323232	2 1/2 - 12	2 1/2 - 12	2 - 11 1/2

ADAPTERS

2602

BRANCH TEE M-JIC / M-JIC / F-NPT

SAE# 070427

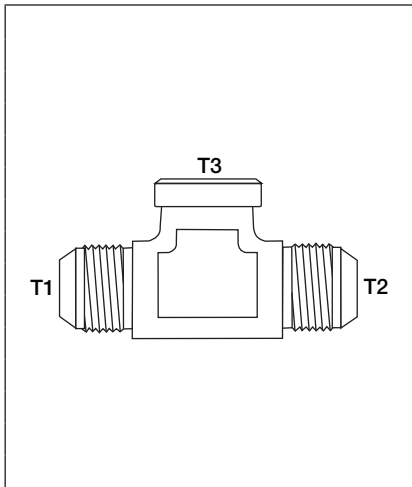

PART NUMBER	T1	T2	T3
2602-040402	7/16 - 20	7/16 - 20	1/8 - 27
2602-040404	7/16 - 20	7/16 - 20	1/4 - 18
2602-050502	1/2 - 20	1/2 - 20	1/8 - 27
2602-060604	9/16 - 18	9/16 - 18	1/4 - 18
2602-060606	9/16 - 18	9/16 - 18	3/8 - 18
2602-080806	3/4 - 16	3/4 - 16	3/8 - 18
2602-080808	3/4 - 16	3/4 - 16	1/2 - 14
2602-101008	7/8 - 14	7/8 - 14	1/2 - 14
2602-121212	1 1/16 - 12	1 1/16 - 12	3/4 - 14
2602-141412	1 3/16 - 12	1 3/16 - 12	3/4 - 14
2602-161616	1 5/16 - 12	1 5/16 - 12	1 - 11 1/2
2602-202020	1 5/8 - 12	1 5/8 - 12	1 1/4 - 11 1/2
2602-242424	1 7/8 - 12	1 7/8 - 12	1 1/2 - 11 1/2
2602-323232	2 1/2 - 12	2 1/2 - 12	2 - 11 1/2

2603

TEE M-JIC / M-JIC / M-JIC

SAE# 070401

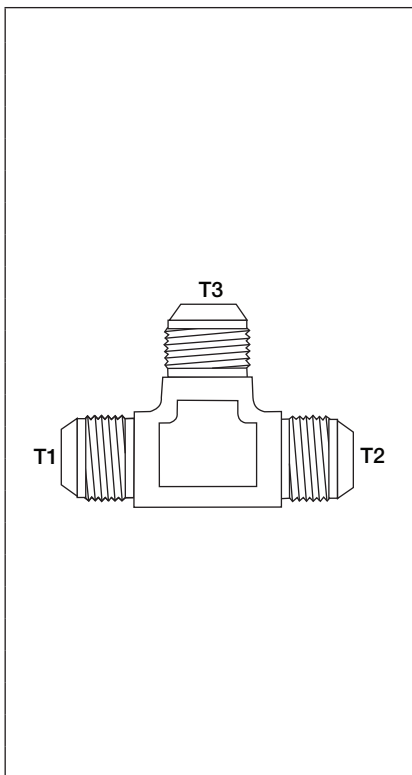

PART NUMBER	T1	T2	T3
2603-020202	5/16 - 24	5/16 - 24	5/16 - 24
2603-030303	3/8 - 24	3/8 - 24	3/8 - 24
2603-040404	7/16 - 20	7/16 - 20	7/16 - 20
2603-040406	7/16 - 20	7/16 - 20	9/16 - 18
2603-050505	1/2 - 20	1/2 - 20	1/2 - 20
2603-060604	9/16 - 18	9/16 - 18	7/16 - 20
2603-060606	9/16 - 18	9/16 - 18	9/16 - 18
2603-060608	9/16 - 18	9/16 - 18	3/4 - 16
2603-080808	3/4 - 16	3/4 - 16	3/4 - 16
2603-080810	3/4 - 16	3/4 - 16	7/8 - 14
2603-080812	3/4 - 16	3/4 - 16	1 1/16 - 12
2603-100808	7/8 - 14	3/4 - 16	3/4 - 16
2603-101008	7/8 - 14	7/8 - 14	3/4 - 16
2603-101010	7/8 - 14	7/8 - 14	7/8 - 14
2603-121208	1 1/16 - 12	1 1/16 - 12	3/4 - 16
2603-121212	1 1/16 - 12	1 1/16 - 12	1 1/16 - 12
2603-121216	1 1/16 - 12	1 1/16 - 12	1 5/16 - 12
2603-141414	1 3/16 - 12	1 3/16 - 12	1 3/16 - 12
2603-161612	1 5/16 - 12	1 5/16 - 12	1 1/16 - 12
2603-161616	1 5/16 - 12	1 5/16 - 12	1 5/16 - 12
2603-202020	1 5/8 - 12	1 5/8 - 12	1 5/8 - 12
2603-242424	1 7/8 - 12	1 7/8 - 12	1 7/8 - 12
2603-323232	2 1/2 - 12	2 1/2 - 12	2 1/2 - 12

ADAPTERS

2605

RUN TEE M-JIC / M-NPT / M-JIC

SAE# 070424

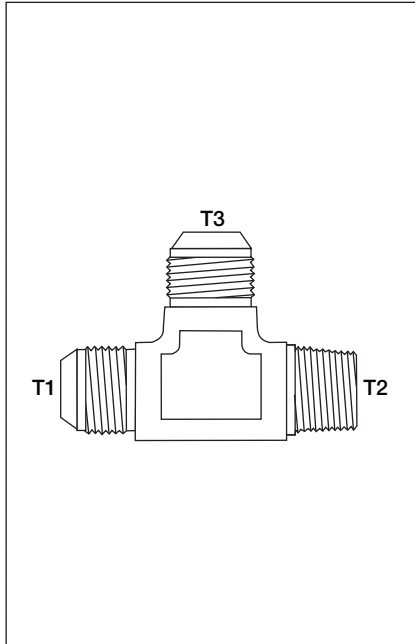

PART NUMBER	T1	T2	T3
2605-040204	7/16 - 20	1/8 - 27	7/16 - 20
2605-040404	7/16 - 20	1/4 - 18	7/16 - 20
2605-050205	1/2 - 20	1/8 - 27	1/2 - 20
2605-060206	9/16 - 18	1/8 - 27	9/16 - 18
2605-060404	9/16 - 18	1/4 - 18	7/16 - 20
2605-060406	9/16 - 18	1/4 - 18	9/16 - 18
2605-060606	9/16 - 18	3/8 - 18	9/16 - 18
2605-060806	9/16 - 18	1/2 - 14	9/16 - 18
2605-080408	3/4 - 16	1/4 - 18	3/4 - 16
2605-080608	3/4 - 16	3/8 - 18	3/4 - 16
2605-080808	3/4 - 16	1/2 - 14	3/4 - 16
2605-100810	7/8 - 14	1/2 - 14	7/8 - 14
2605-121208	1 1/16 - 12	3/4 - 14	3/4 - 16
2605-121212	1 1/16 - 12	3/4 - 14	1 1/16 - 12
2605-141214	1 3/16 - 12	3/4 - 14	1 3/16 - 12
2605-161616	1 5/16 - 12	1 - 11 1/2	1 5/16 - 12
2605-202020	1 5/8 - 12	1 1/4 - 11 1/2	1 5/8 - 12
2605-242424	1 7/8 - 12	1 1/2 - 11 1/2	1 7/8 - 12
2605-323232	2 1/2 - 12	2 - 11 1/2	2 1/2 - 12

2606

RUN TEE M-JIC / F-NPT / M-JIC

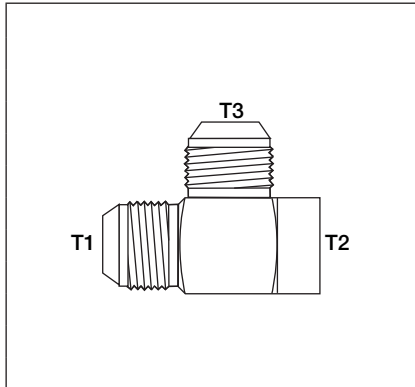

PART NUMBER	T1	T2	T3
2606-030203	3/8 - 24	1/8 - 27	3/8 - 24
2606-040204	7/16 - 20	1/8 - 27	7/16 - 20
2606-040404	7/16 - 20	1/4 - 18	7/16 - 20
2606-060406	9/16 - 18	1/4 - 18	9/16 - 18
2606-060606	9/16 - 18	3/8 - 18	9/16 - 18
2606-080608	3/4 - 16	3/8 - 18	3/4 - 16
2606-100810	7/8 - 14	1/2 - 14	7/8 - 14
2606-121212	1 1/16 - 12	3/4 - 14	1 1/16 - 12
2606-141214	1 3/16 - 12	3/4 - 14	1 3/16 - 12
2606-161616	1 5/16 - 12	1 - 11 1/2	1 5/16 - 12
2606-202020	1 5/8 - 12	1 1/4 - 11 1/2	1 5/8 - 12

2609

RUN TEE M-JIC / F-NPT / F-NPT

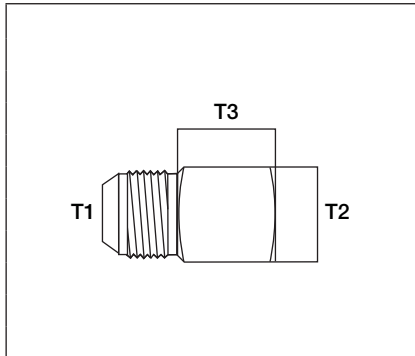

PART NUMBER	T1	T2	T3
2609-040202	7/16 - 20	1/8 - 27	1/8 - 27
2609-040404	7/16 - 20	1/4 - 18	1/4 - 18
2609-050404	1/2 - 20	1/4 - 18	1/4 - 18
2609-060404	9/16 - 18	1/4 - 18	1/4 - 18
2609-080606	3/4 - 16	3/8 - 18	3/8 - 18
2609-080808	3/4 - 16	1/2 - 14	1/2 - 14
2609-100808	7/8 - 14	1/2 - 14	1/2 - 14
2609-121212	1 1/16 - 12	3/4 - 14	3/4 - 14
2609-161616	1 5/16 - 12	1 - 11 1/2	1 - 11 1/2
2609-202020	1 5/8 - 12	1 1/4 - 11 1/2	1 1/4 - 11 1/2

ADAPTERS

2613 RUN TEE M-NPT / F-NPT / M-JIC

	PART NUMBER	T1	T2	T3
	2613-020204	1/8 - 27	1/8 - 27	7/16 - 20
	2613-040406	1/4 - 18	1/4 - 18	9/16 - 18
	2613-060606	3/8 - 18	3/8 - 18	9/16 - 18
	2613-060608	3/8 - 18	3/8 - 18	3/4 - 16
	2613-080810	1/2 - 14	1/2 - 14	7/8 - 14
	2613-121212	3/4 - 14	3/4 - 14	1 1/16 - 12
	2613-161616	1 - 11 1/2	1 - 11 1/2	1 5/16 - 12

2650 CROSS M-JIC

	PART NUMBER	T1	T2	T3	T4
	2650-02020202	5/16 - 24	5/16 - 24	5/16 - 24	5/16 - 24
	2650-04040404	7/16 - 20	7/16 - 20	7/16 - 20	7/16 - 20
	2650-05050505	1/2 - 20	1/2 - 20	1/2 - 20	1/2 - 20
	2650-06060606	9/16 - 18	9/16 - 18	9/16 - 18	9/16 - 18
	2650-06080608	9/16 - 18	3/4 - 16	9/16 - 18	3/4 - 16
	2650-08080808	3/4 - 16	3/4 - 16	3/4 - 16	3/4 - 16
	2650-10101010	7/8 - 14	7/8 - 14	7/8 - 14	7/8 - 14
	2650-12121212	1 1/16 - 12	1 1/16 - 12	1 1/16 - 12	1 1/16 - 12
	2650-14141414	1 3/16 - 12	1 3/16 - 12	1 3/16 - 12	1 3/16 - 12
	2650-16161616	1 5/16 - 12	1 5/16 - 12	1 5/16 - 12	1 5/8 - 12
	2650-20202020	1 5/8 - 12	1 5/8 - 12	1 5/8 - 12	1 5/8 - 12
	2650-24242424	1 7/8 - 12	1 7/8 - 12	1 7/8 - 12	1 7/8 - 12

2700LN M-JIC BULKHEAD STRAIGHT INCLUDES NUT

	PART NUMBER	T1	T2
	2700LN-0404	7/16 - 20	7/16 - 20
	2700LN-0406	7/16 - 20	9/16 - 18
	2700LN-0505	1/2 - 20	1/2 - 20
	2700LN-0604	9/16 - 18	7/16 - 20
	2700LN-0606	9/16 - 18	9/16 - 18
	2700LN-0808	3/4 - 16	3/4 - 16
	2700LN-1010	7/8 - 14	7/8 - 14
	2700LN-1212	1 1/16 - 12	1 1/16 - 12
	2700LN-1414	1 3/16 - 12	1 3/16 - 12
	2700LN-1616	1 5/16 - 12	1 5/16 - 12
	2700LN-2020	1 5/8 - 12	1 5/8 - 12
	2700LN-2424	1 7/8 - 12	1 7/8 - 12

ADAPTERS

2701LN 90° M-JIC BULKHEAD INCLUDES NUT

SAE# 070701

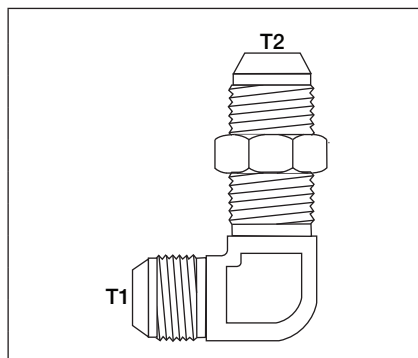

PART NUMBER	T1	T2
2701LN-0303	3/8 - 24	3/8 - 24
2701LN-0404	7/16 - 20	7/16 - 20
2701LN-0505	1/2 - 20	1/2 - 20
2701LN-0606	9/16 - 18	9/16 - 18
2701LN-0808	3/4 - 16	3/4 - 16
2701LN-1010	7/8 - 14	7/8 - 14
2701LN-1212	1 1/16 - 12	1 1/16 - 12
2701LN-1616	1 5/16 - 12	1 5/16 - 12
2701LN-2020	1 7/8 - 12	1 7/8 - 12

2702LN 45° M-JIC BULKHEAD INCLUDES NUT

SAE# 070801

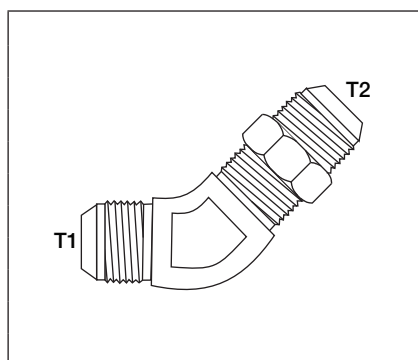

PART NUMBER	T1	T2
2702LN-0303	3/8 - 24	3/8 - 24
2702LN-0404	7/16 - 20	7/16 - 20
2702LN-0505	1/2 - 20	1/2 - 20
2702LN-0606	9/16 - 18	9/16 - 18
2702LN-0808	3/4 - 16	3/4 - 16
2702LN-1010	7/8 - 14	7/8 - 14
2702LN-1212	1 1/16 - 12	1 1/16 - 12
2702LN-1616	1 5/16 - 12	1 5/16 - 12
2702LN-2020	1 7/8 - 12	1 7/8 - 12
2702LN-2424	1 7/8 - 12	1 7/8 - 12

2703LN BRANCH TEE M-JIC BULKHEAD INCLUDES NUT

SAE# 070959

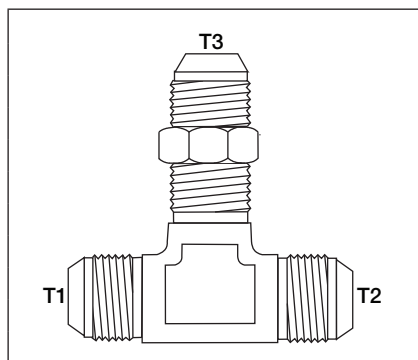

PART NUMBER	T1	T2	T3
2703LN-030303	3/8 - 24	3/8 - 24	3/8 - 24
2703LN-040404	7/16 - 20	7/16 - 20	7/16 - 20
2703LN-040406	7/16 - 20	7/16 - 20	9/16 - 18
2703LN-050505	1/2 - 20	1/2 - 20	1/2 - 20
2703LN-060606	9/16 - 18	9/16 - 18	9/16 - 18
2703LN-080808	3/4 - 16	3/4 - 16	3/4 - 16
2703LN-101010	7/8 - 14	7/8 - 14	7/8 - 14
2703LN-121212	1 1/16 - 12	1 1/16 - 12	1 1/16 - 12
2703LN-161616	1 5/16 - 12	1 5/16 - 12	1 5/16 - 12
2703LN-202020	1 7/8 - 12	1 5/8 - 12	1 5/8 - 12

ADAPTERS

2704LN

RUN TEE M-JIC BULKHEAD INCLUDES NUT

SAE# 070958

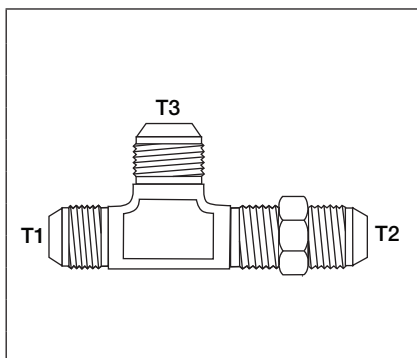

PART NUMBER	T1	T2	T3
2704LN-030303	3/8 - 24	3/8 - 24	3/8 - 24
2704LN-040404	7/16 - 20	7/16 - 20	7/16 - 20
2704LN-050505	1/2 - 20	1/2 - 20	1/2 - 20
2704LN-060606	9/16 - 18	9/16 - 18	9/16 - 18
2704LN-080808	3/4 - 16	3/4 - 16	3/4 - 16
2704LN-101010	7/8 - 14	7/8 - 14	7/8 - 14
2704LN-121212	1 1/16 - 12	1 1/16 - 12	1 1/16 - 12
2704LN-161616	1 5/16 - 12	1 5/16 - 12	1 5/16 - 12
2704LN-202020	1 5/8 - 12	1 5/8 - 12	1 5/8 - 12
2704LN-242424	1 7/8 - 12	1 7/8 - 12	1 7/8 - 12

2705LN

F-NPT / M-JIC BULKHEAD INCLUDES NUT

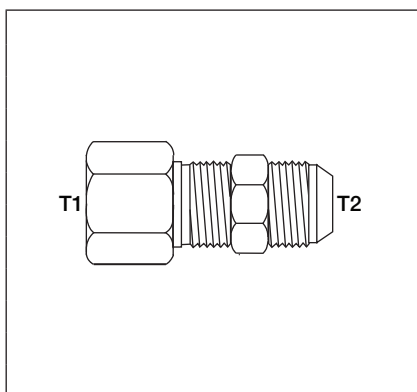

PART NUMBER	T1	T2
2705LN-0204	1/8 - 27	7/16 - 20
2705LN-0404	1/4 - 18	7/16 - 20
2705LN-0406	1/4 - 18	9/16 - 18
2705LN-0606	3/8 - 18	9/16 - 18
2705LN-0608	3/8 - 18	3/4 - 16
2705LN-0808	1/2 - 14	3/4 - 16
2705LN-0810	1/2 - 14	7/8 - 14
2705LN-1212	3/4 - 14	1 1/16 - 12
2705LN-1616	1 - 11 1/2	1 5/16 - 12
2705LN-2020	1 1/4 - 11 1/2	1 5/8 - 12
2705LN-2424	1 1/2 - 11 1/2	1 7/8 - 12

2706LN

M-NPT / M-JIC BULKHEAD INCLUDES NUT

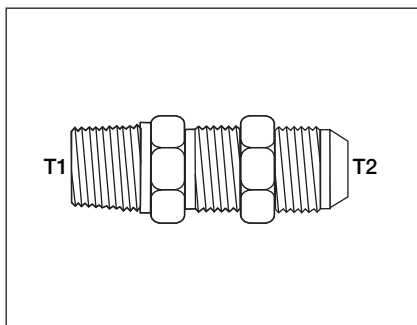

PART NUMBER	T1	T2
2706LN-0204	1/8 - 27	7/16 - 20
2706LN-0404	1/4 - 18	7/16 - 20
2706LN-0406	1/4 - 18	9/16 - 18
2706LN-0606	3/8 - 18	9/16 - 18
2706LN-0608	3/8 - 18	3/4 - 16
2706LN-0808	1/2 - 14	3/4 - 16
2706LN-0810	1/2 - 14	7/8 - 14
2706LN-1212	3/4 - 14	1 1/16 - 12
2706LN-1616	1 - 11 1/2	1 5/16 - 12

ADAPTERS

3474 M-ORB / ADJ M-ORB

	PART NUMBER	T1	T2
	3474-0404	7/16 - 20	7/16 - 20
	3474-0606	9/16 - 18	9/16 - 18
	3474-0808	3/4 - 16	3/4 - 16
	3474-1010	7/8 - 14	7/8 - 14
	3474-1212	1 1/16 - 12	1 1/16 - 12
	3474-1616	1 5/16 - 12	1 5/16 - 12
	3474-2020	1 5/8 - 12	1 5/8 - 12
	3474-2424	1 7/8 - 12	1 7/8 - 12
	3474-3232	2 1/2 - 12	2 1/2 - 12

4404 HB / M-NPT STRAIGHT

	PART NUMBER	T1	T2
	4404-0402	1/4	1/8 - 27
	4404-0404	1/4	1/4 - 18
	4404-0602	3/8	1/8 - 27
	4404-0604	3/8	1/4 - 18
	4404-0606	3/8	3/8 - 18
	4404-0804	1/2	1/4 - 18
	4404-0806	1/2	3/8 - 18
	4404-0808	1/2	1/2 - 14
	4404-0812	1/2	3/4 - 14
	4404-1006	5/8	3/8 - 18
	4404-1008	5/8	1/2 - 14
	4404-1208	3/4	1/2 - 14
	4404-1212	3/4	3/4 - 14
	4404-1612	1	3/4 - 14
	4404-1616	1	1 - 11 1/2
	4404-2016	1 1/4	1 - 11 1/2
	4404-2020	1 1/4	1 1/4 - 11 1/2
	4404-2024	1 1/4	1 1/2 - 11 1/2
	4404-2420	1 1/2	1 1/4 - 11 1/2
	4404-2424	1 1/2	1 1/2 - 11 1/2

ADAPTERS

4501

90° HB / M-NPT

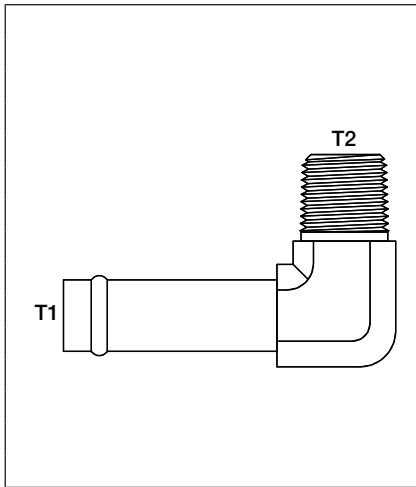

PART NUMBER	T1	T2
4501-0402	1/4	1/8 - 27
4501-0404	1/4	1/4- 18
4501-0604	3/8	1/4- 18
4501-0606	3/8	3/8 - 18
4501-0806	1/2	3/8 - 18
4501-0808	1/2	1/2- 14
4501-0812	1/2	3/4- 14
4501-1008	5/8	1/2- 14
4501-1012	5/8	3/4- 14
4501-1208	3/4	1/2- 14
4501-1212	3/4	3/4- 14
4501-1216	3/4	1- 11 1/2
4501-1612	1	3/4- 14
4501-1616	1	1- 11 1/2

4503

45° HB / M-NPT

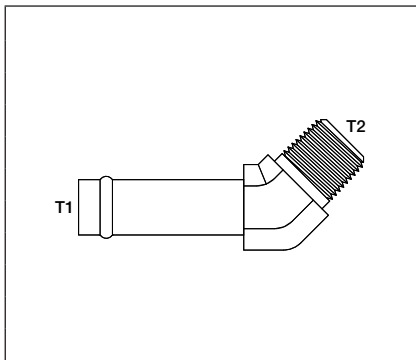

PART NUMBER	T1	T2
4503-0402	1/4	1/8 - 27
4503-0404	1/4	1/4- 18
4503-0604	3/8	1/4- 18
4503-0806	1/2	3/8 - 18
4503-0808	1/2	1/2- 14
4503-1008	5/8	1/2- 14
4503-1212	3/4	3/4- 14
4503-1616	1	1- 11 1/2
4503-2020	1 1/4	1 1/4- 11 1/2
4503-2424	1 1/2	1 1/2- 11 1/2

ADAPTERS

4601

90° HB / M-ORB

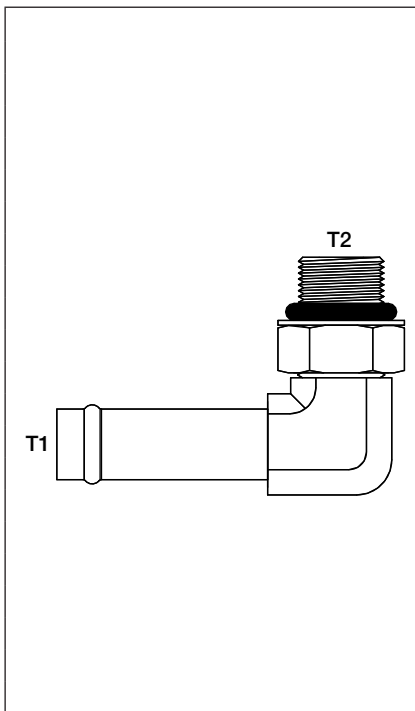

PART NUMBER	T1	T2
4601-0404	1/4	7/16 - 20
4601-0406	1/4	9/16 - 18
4601-0604	3/8	7/16 - 20
4601-0606	3/8	9/16 - 18
4601-0608	3/8	3/4 - 16
4601-0806	1/2	9/16 - 18
4601-0808	1/2	3/4 - 16
4601-1008	5/8	3/4 - 16
4601-1010	5/8	7/8 - 14
4601-1012	5/8	1 1/16 - 12
4601-1208	3/4	3/4 - 16
4601-1210	3/4	7/8 - 14
4601-1212	3/4	1 1/16 - 12
4601-1216	3/4	1 5/16 - 12
4601-1610	1	7/8 - 14
4601-1612	1	1 1/16 - 12
4601-1616	1	1 5/16 - 12
4601-1620	1	1 5/8 - 12
4601-2016	1 1/4	1 5/16 - 12
4601-2020	1 1/4	1 5/8 - 12
4601-2424	1 1/2	1 7/8 - 12

4603

45° HB / M-ORB

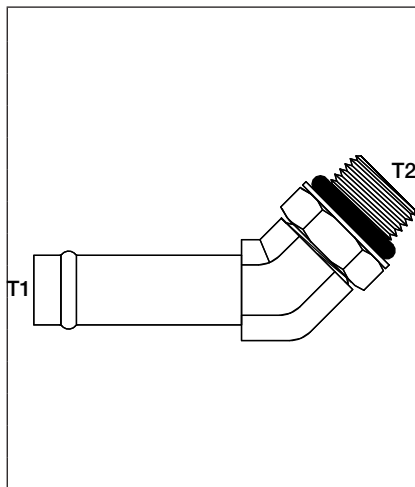

PART NUMBER	T1	T2
4603-0404	1/4	7/16 - 20
4603-0606	3/8	9/16 - 18
4603-0808	1/2	3/4 - 16
4603-1010	5/8	7/8 - 14
4603-1012	5/8	1 1/16 - 12
4603-1208	3/4	3/4 - 16
4603-1210	3/4	7/8 - 14
4603-1212	3/4	1 1/16 - 12
4603-1612	1	1 1/16 - 12
4603-1616	1	1 5/16 - 12
4603-2016	1 1/4	1 5/16 - 12
4603-2020	1 1/4	1 5/8 - 12
4603-2420	1 1/2	1 5/8 - 12
4603-2424	1 1/2	1 7/8 - 12

ADAPTERS

4604

HB / M-ORB STRAIGHT

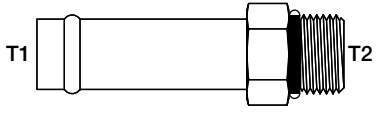
	PART NUMBER		
	T1	T2	
4604-0404	1/4	7/16 - 20	
4604-0604	3/8	7/16 - 20	
4604-0606	3/8	9/16 - 18	
4604-0806	1/2	9/16 - 18	
4604-0808	1/2	3/4 - 16	
4604-1008	5/8	3/4 - 16	
4604-1010	5/8	7/8 - 14	
4604-1208	3/4	3/4 - 16	
4604-1210	3/4	7/8 - 14	
4604-1212	3/4	1 1/16 - 12	
4604-1216	3/4	1 5/16 - 12	
4604-1612	1	1 1/16 - 12	
4604-1616	1	1 5/16 - 12	
4604-1620	1	1 5/8 - 12	
4604-2016	1 1/4	1 5/16 - 12	
4604-2020	1 1/4	1 5/8 - 12	
4604-2024	1 1/4	1 7/8 - 12	
4604-2424	1 1/2	1 7/8 - 12	

5000

F-NPT / F-NPT

SAE# 140138

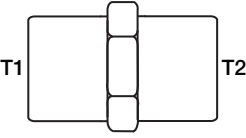
	PART NUMBER		
	T1	T2	
5000-0202	1/8 - 27	1/8 - 27	
5000-0402	1/4 - 18	1/8 - 27	
5000-0404	1/4 - 18	1/4 - 18	
5000-0604	3/8 - 18	1/4 - 18	
5000-0606	3/8 - 18	3/8 - 18	
5000-0804	1/2 - 14	1/4 - 18	
5000-0806	1/2 - 14	3/8 - 18	
5000-0808	1/2 - 14	1/2 - 14	
5000-1206	3/4 - 14	3/8 - 18	
5000-1208	3/4 - 14	1/2 - 14	
5000-1212	3/4 - 14	3/4 - 14	
5000-1612	1 - 11 1/2	3/4 - 14	
5000-1616	1 - 11 1/2	1 - 11 1/2	
5000-2020	1 1/4 - 11 1/2	1 1/4 - 11 1/2	
5000-2424	1 1/2 - 11 1/2	1 1/2 - 11 1/2	
5000-3232	2 - 11 1/2	2 - 11 1/2	

ADAPTERS

5404

M-NPT / M-NPT

SAE# 140137

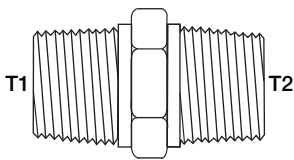

PART NUMBER	T1	T2
5404-0202	1/8 - 27	1/8 - 27
5404-0402	1/4 - 18	1/8 - 27
5404-0404	1/4 - 18	1/4 - 18
5404-0602	3/8 - 18	1/8 - 27
5404-0604	3/8 - 18	1/4 - 18
5404-0606	3/8 - 18	3/8 - 18
5404-0804	1/2 - 14	1/4 - 18
5404-0806	1/2 - 14	3/8 - 18
5404-0808	1/2 - 14	1/2 - 14
5404-1206	3/4 - 14	3/8 - 18
5404-1208	3/4 - 14	1/2 - 14
5404-1212	3/4 - 14	3/4 - 14
5404-1606	1 - 11 1/2	3/8 - 18
5404-1608	1 - 11 1/2	1/2 - 14
5404-1612	1 - 11 1/2	3/4 - 14
5404-1616	1 - 11 1/2	1 - 11 1/2
5404-2012	1 1/4 - 11 1/2	3/4 - 14
5404-2016	1 1/4 - 11 1/2	1 - 11 1/2
5404-2020	1 1/4 - 11 1/2	1 1/4 - 11 1/2
5404-2412	1 1/2 - 11 1/2	3/4 - 14
5404-2416	1 1/2 - 11 1/2	1 - 11 1/2
5404-2420	1 1/2 - 11 1/2	1 1/4 - 11 1/2
5404-2424	1 1/2 - 11 1/2	1 1/2 - 11 1/2
5404-3220	2 - 11 1/2	1 1/4 - 11 1/2
5404-3224	2 - 11 1/2	1 1/2 - 11 1/2
5404-3232	2 - 11 1/2	2 - 11 1/2

5405

M-NPT / F-NPT

SAE# 140139

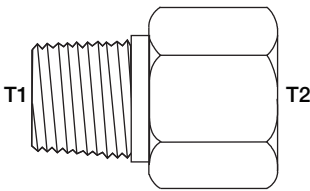

PART NUMBER	T1	T2
5405-0202	1/8 - 27	1/8 - 27
5405-0204	1/8 - 27	1/4 - 18
5405-0208	1/8 - 27	1/2 - 14
5405-0404	1/4 - 18	1/4 - 18
5405-0406	1/4 - 18	3/8 - 18
5405-0408	1/4 - 18	1/2 - 14
5405-0604	3/8 - 18	1/4 - 18
5405-0606	3/8 - 18	3/8 - 18
5405-0608	3/8 - 18	1/2 - 14
5405-0612	3/8 - 18	3/4 - 14
5405-0806	1/2 - 14	3/8 - 18
5405-0808	1/2 - 14	1/2 - 14
5405-0812	1/2 - 14	3/4 - 14
5405-0816	1/2 - 14	1 - 11 1/2
5405-1212	3/4 - 14	3/4 - 14
5405-1216	3/4 - 14	1 - 11 1/2
5405-1616	1 - 11 1/2	1 - 11 1/2
5405-1620	1 - 11 1/2	1 1/4 - 11 1/2
5405-2016	1 1/4 - 11 1/2	1 - 11 1/2
5405-2024	1 1/4 - 11 1/2	1 1/2 - 11 1/2
5405-2432	1 1/2 - 11 1/2	2 - 11 1/2

ADAPTERS

5406

M-NPT / F-NPT

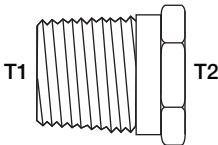
	PART NUMBER	T1	T2
	5406-0402	1/4 - 18	1/8 - 27
5406-0602	3/8 - 18	1/8 - 27	
5406-0604	3/8 - 18	1/4 - 18	
5406-0802	1/2 - 14	1/8 - 27	
5406-0804	1/2 - 14	1/4 - 18	
5406-0806	1/2 - 14	3/8 - 18	
5406-1204	3/4 - 14	1/4 - 18	
5406-1206	3/4 - 14	3/8 - 18	
5406-1208	3/4 - 14	1/2 - 14	
5406-1604	1 - 11 1/2	1/4 - 18	
5406-1606	1 - 11 1/2	3/8 - 18	
5406-1608	1 - 11 1/2	1/2 - 14	
5406-1612	1 - 11 1/2	3/4 - 14	
5406-2004	1 1/4 - 11 1/2	1/4 - 18	
5406-2006	1 1/4 - 11 1/2	3/8 - 18	
5406-2008	1 1/4 - 11 1/2	1/2 - 14	
5406-2012	1 1/4 - 11 1/2	3/4 - 14	
5406-2016	1 1/4 - 11 1/2	1 - 11 1/2	
5406-2406	1 1/2 - 11 1/2	3/8 - 18	
5406-2412	1 1/2 - 11 1/2	3/4 - 14	
5406-2416	1 1/2 - 11 1/2	1 - 11 1/2	
5406-2420	1 1/2 - 11 1/2	1 1/4 - 11 1/2	
5406-3220	2 - 11 1/2	1 1/4 - 11 1/2	
5406-3224	2 - 11 1/2	1 1/2 - 11 1/2	

5406C

NPT CAP

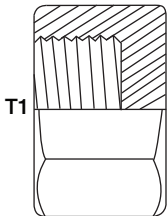
	PART NUMBER	T1
	5406C-02	1/8 - 27
5406C-04	1/4 - 18	
5406C-06	3/8 - 18	
5406C-08	1/2 - 14	
5406C-12	3/4 - 14	
5406C-16	1 - 11 1/2	
5406C-20	1 1/4 - 11 1/2	
5406C-24	1 1/2 - 11 1/2	
5406C-32	2 - 11 1/2	

5406P

NPT PLUG

SAE# 130109E

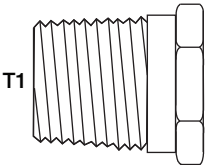
	PART NUMBER	T1
	5406P-02	1/8 - 27
5406P-04	1/4 - 18	
5406P-06	3/8 - 18	
5406P-08	1/2 - 14	
5406P-12	3/4 - 14	
5406P-16	1 - 11 1/2	
5406P-20	1 1/4 - 11 1/2	
5406P-24	1 1/2 - 11 1/2	
5406P-32	2 - 11 1/2	

ADAPTERS

5406HP NPT HOLLOW HEX PLUG

	PART NUMBER	T1
	5406HP-02	1/8 - 27
	5406HP-04	1/4 - 18
	5406HP-06	3/8 - 18
	5406HP-08	1/2 - 14
	5406HP-12	3/4 - 14
	5406HP-16	1 - 11 1/2
	5406HP-20	1 1/4 - 11 1/2
	5406HP-24	1 1/2 - 11 1/2
5406HP-32	2 - 11 1/2	

5406SHP SQUARE HEAD PIPE PLUG

	PART NUMBER	T1
	5406SHP-02	1/8 - 27
	5406SHP-04	1/4 - 18
	5406SHP-06	3/8 - 18
	5406SHP-08	1/2 - 14
	5406SHP-12	3/4 - 14
	5406SHP-16	1 - 11 1/2

5500 90° M-NPT / M-NPT

SAE# 140237

	PART NUMBER	T1	T2
	5500-0202	1/8 - 27	1/8 - 27
	5500-0402	1/4 - 18	1/8 - 27
	5500-0404	1/4 - 18	1/4 - 18
	5500-0604	3/8 - 18	1/4 - 18
	5500-0606	3/8 - 18	3/8 - 18
	5500-0804	1/2 - 14	1/4 - 18
	5500-0806	1/2 - 14	3/8 - 18
	5500-0808	1/2 - 14	1/2 - 14
	5500-1208	3/4 - 14	1/2 - 14
	5500-1212	3/4 - 14	3/4 - 14
	5500-1608	1 - 11 1/2	1/2 - 14
	5500-1612	1 - 11 1/2	3/4 - 14
	5500-1616	1 - 11 1/2	1 - 11 1/2
	5500-2020	1 1/4 - 11 1/2	1 1/4 - 11 1/2
	5500-2424	1 1/2 - 11 1/2	1 1/2 - 11 1/2
	5500-3232	2 - 11 1/2	2 - 11 1/2

ADAPTERS

5501 45° M-NPT / M-NPT

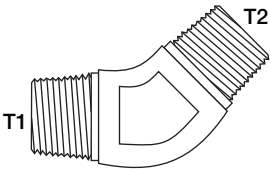
	PART NUMBER	T1	T2
	5501-0404	1/4 - 18	1/4 - 18
	5501-0606	3/8 - 18	3/8 - 18
	5501-0808	1/2 - 14	1/2 - 14
	5501-1212	3/4 - 14	3/4 - 14
	5501-1616	1 - 11 1/2	1 - 11 1/2
	5501-2020	1 1/4 - 11 1/2	1 1/4 - 11 1/2
	5501-2424	1 1/2 - 11 1/2	1 1/2 - 11 1/2

5502 90° M-NPT / F-NPT

SAE# 140239

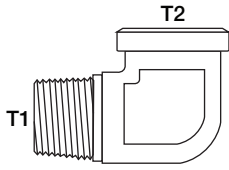
	PART NUMBER	T1	T2
	5502-0202	1/8 - 27	1/8 - 27
	5502-0204	1/8 - 27	1/4 - 18
	5502-0402	1/4 - 18	1/8 - 27
	5502-0404	1/4 - 18	1/4 - 18
	5502-0406	1/4 - 18	3/8 - 18
	5502-0604	3/8 - 18	1/4 - 18
	5502-0606	3/8 - 18	3/8 - 18
	5502-0608	3/8 - 18	1/2 - 14
	5502-0804	1/2 - 14	1/4 - 18
	5502-0806	1/2 - 14	3/8 - 18
	5502-0808	1/2 - 14	1/2 - 14
	5502-0812	1/2 - 14	3/4 - 14
	5502-1208	3/4 - 14	1/2 - 14
	5502-1212	3/4 - 14	3/4 - 14
	5502-1612	1 - 11 1/2	3/4 - 14
	5502-1616	1 - 11 1/2	1 - 11 1/2
	5502-2016	1 1/4 - 11 1/2	1 - 11 1/2
	5502-2020	1 1/4 - 11 1/2	1 1/4 - 11 1/2
	5502-2424	1 1/2 - 11 1/2	1 1/2 - 11 1/2
5502-3232	2 - 11 1/2	2 - 11 1/2	

5503 45° M-NPT / F-NPT

SAE# 140339

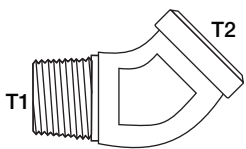
	PART NUMBER	T1	T2
	5503-0202	1/8 - 27	1/8 - 27
	5503-0404	1/4 - 18	1/4 - 18
	5503-0606	3/8 - 18	3/8 - 18
	5503-0808	1/2 - 14	1/2 - 14
	5503-1212	3/4 - 14	3/4 - 14
	5503-1616	1 - 11 1/2	1 - 11 1/2
	5503-2020	1 1/4 - 11 1/2	1 1/4 - 11 1/2
5503-2424	1 1/2 - 11 1/2	1 1/2 - 11 1/2	

ADAPTERS

5504

90° F-NPT / F-NPT

SAE# 140238

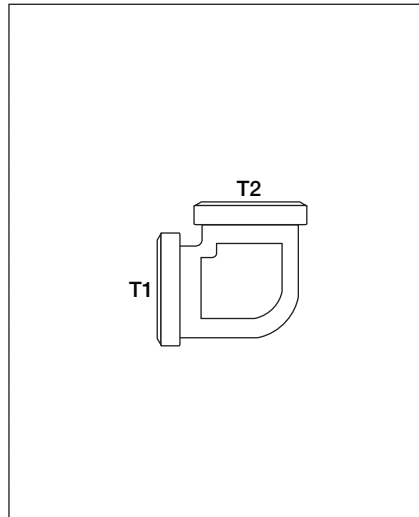

PART NUMBER	T1	T2
5504-0202	1/8 - 27	1/8 - 27
5504-0402	1/4 - 18	1/8 - 27
5504-0404	1/4 - 18	1/4 - 18
5504-0604	3/8 - 18	1/4 - 18
5504-0606	3/8 - 18	3/8 - 18
5504-0804	1/2 - 14	1/4 - 18
5504-0806	1/2 - 14	3/8 - 18
5504-0808	1/2 - 14	1/2 - 14
5504-1208	3/4 - 14	1/2 - 14
5504-1212	3/4 - 14	3/4 - 14
5504-1612	1 - 11 1/2	3/4 - 14
5504-1616	1 - 11 1/2	1 - 11 1/2
5504-2020	1 1/4 - 11 1/2	1 1/4 - 11 1/2
5504-2424	1 1/2 - 11 1/2	1 1/2 - 11 1/2
5504-3232	2 - 11 1/2	2 - 11 1/2

5505

45° F-NPT / F-NPT

SAE# 140338

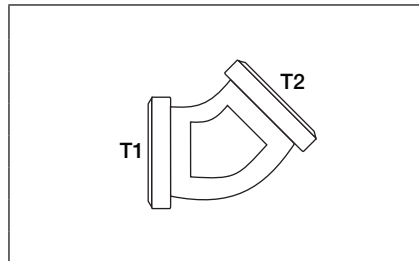

PART NUMBER	T1	T2
5505-0202	1/8 - 27	1/8 - 27
5505-0404	1/4 - 18	1/4 - 18
5505-0606	3/8 - 18	3/8 - 18
5505-0808	1/2 - 14	1/2 - 14
5505-1212	3/4 - 14	3/4 - 14
5505-1616	1 - 11 1/2	1 - 11 1/2

5600

TEE M-NPT

SAE# 140437
(As coded per SAE J846)

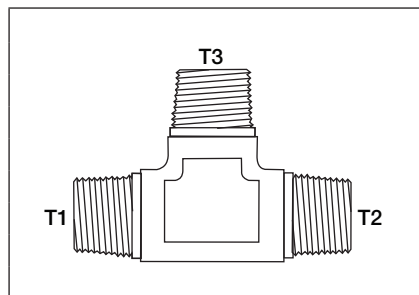

PART NUMBER	T1	T2	T3
5600-020202	1/8 - 27	1/8 - 27	1/8 - 27
5600-040404	1/4 - 18	1/4 - 18	1/4 - 18
5600-060606	3/8 - 18	3/8 - 18	3/8 - 18
5600-080808	1/2 - 14	1/2 - 14	1/2 - 14
5600-121212	3/4 - 14	3/4 - 14	3/4 - 14
5600-161616	1 - 11 1/2	1 - 11 1/2	1 - 11 1/2

5601

BRANCH TEE M-NPT / M-NPT / F-NPT

SAE# 140427
(As coded per SAE J846)

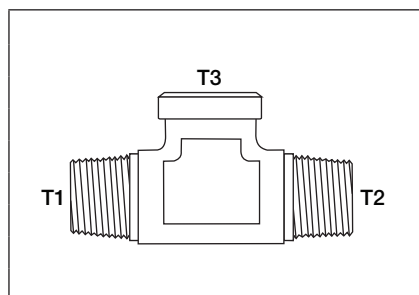

PART NUMBER	T1	T2	T3
5601-020202	1/8 - 27	1/8 - 27	1/8 - 27
5601-040404	1/4 - 18	1/4 - 18	1/4 - 18
5601-060606	3/8 - 18	3/8 - 18	3/8 - 18
5601-080808	1/2 - 14	1/2 - 14	1/2 - 14
5601-121212	3/4 - 14	3/4 - 14	3/4 - 14
5601-161616	1 - 11 1/2	1 - 11 1/2	1 - 11 1/2
5601-202020	1 1/4 - 11 1/2	1 1/4 - 11 1/2	1 1/4 - 11 1/2
5601-242424	1 1/2 - 11 1/2	1 1/2 - 11 1/2	1 1/2 - 11 1/2

ADAPTERS

5602

RUN TEE M-NPT / F-NPT / F-NPT

SAE# 140424

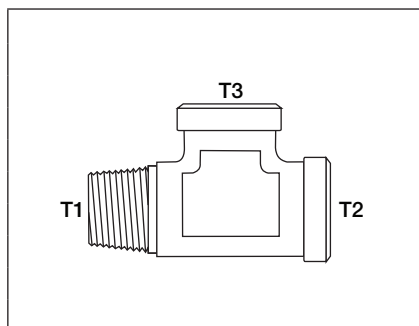

PART NUMBER	T1	T2	T3
5602-020202	1/8 - 27	1/8 - 27	1/8 - 27
5602-040404	1/4 - 18	1/4 - 18	1/4 - 18
5602-060606	3/8 - 18	3/8 - 18	3/8 - 18
5602-080808	1/2 - 14	1/2 - 14	1/2 - 14
5602-121212	3/4 - 14	3/4 - 14	3/4 - 14
5602-161616	1 - 11½	1 - 11½	1 - 11½
5602-202020	1¼ - 11½	1¼ - 11½	1¼ - 11½
5602-242424	1½ - 11½	1½ - 11½	1½ - 11½
5602-323232	2 - 11½	2 - 11½	2 - 11½

5603

RUN TEE M-NPT / F-NPT / M-NPT

SAE# 140426
(As coded per SAE J846)

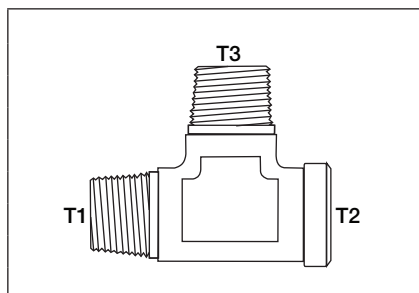

PART NUMBER	T1	T2	T3
5603-020202	1/8 - 27	1/8 - 27	1/8 - 27
5603-040404	1/4 - 18	1/4 - 18	1/4 - 18
5603-060606	3/8 - 18	3/8 - 18	3/8 - 18
5603-080808	1/2 - 14	1/2 - 14	1/2 - 14
5603-121212	3/4 - 14	3/4 - 14	3/4 - 14
5603-161616	1 - 11½	1 - 11½	1 - 11½
5603-202020	1¼ - 11½	1¼ - 11½	1¼ - 11½
5603-242424	1½ - 11½	1½ - 11½	1½ - 11½

5604

BRANCH TEE F-NPT / F-NPT / M-NPT

SAE# 140425

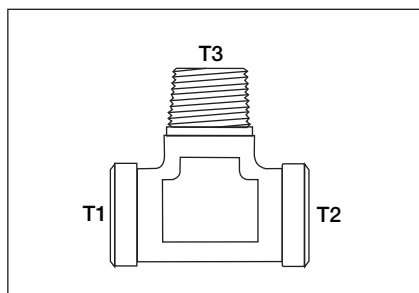

PART NUMBER	T1	T2	T3
5604-020202	1/8 - 27	1/8 - 27	1/8 - 27
5604-040404	1/4 - 18	1/4 - 18	1/4 - 18
5604-060606	3/8 - 18	3/8 - 18	3/8 - 18
5604-080808	1/2 - 14	1/2 - 14	1/2 - 14
5604-121212	3/4 - 14	3/4 - 14	3/4 - 14
5604-161616	1 - 11½	1 - 11½	1 - 11½
5604-202020	1¼ - 11½	1¼ - 11½	1¼ - 11½
5604-242424	1½ - 11½	1½ - 11½	1½ - 11½

5605

TEE F-NPT

SAE# 140438

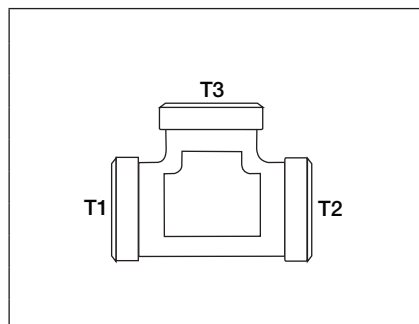

PART NUMBER	T1	T2	T3
5605-020202	1/8 - 27	1/8 - 27	1/8 - 27
5605-040404	1/4 - 18	1/4 - 18	1/4 - 18
5605-060606	3/8 - 18	3/8 - 18	3/8 - 18
5605-080808	1/2 - 14	1/2 - 14	1/2 - 14
5605-121212	3/4 - 14	3/4 - 14	3/4 - 14
5605-161616	1 - 11½	1 - 11½	1 - 11½
5605-202020	1¼ - 11½	1¼ - 11½	1¼ - 11½
5605-242424	1½ - 11½	1½ - 11½	1½ - 11½
5605-323232	2 - 11½	2 - 11½	2 - 11½

ADAPTERS

5652

CROSS F-NPT

SAE# 140538
(As coded per SAE J846)

	PART NUMBER	T1	T2	T3	T4
	5652-02020202	1/8 - 27	1/8 - 27	1/8 - 27	1/8 - 27
	5652-04040404	1/4 - 18	1/4 - 18	3/8 - 18	3/8 - 18
	5652-06060606	3/8 - 18	3/8 - 18	1/2 - 14	1/2 - 14
	5652-08080808	1/2 - 14	1/2 - 14	3/4 - 14	3/4 - 14
	5652-12121212	3/4 - 14	3/4 - 14	1 - 11 1/2	1 - 11 1/2
	5652-16161616	1 - 11 1/2	1 - 11 1/2	1 1/4 - 11 1/2	1 1/4 - 11 1/2
	5652-20202020	1 1/4 - 11 1/2	1 1/4 - 11 1/2	1 1/2 - 11 1/2	1 1/2 - 11 1/2
	5652-24242424	1 1/2 - 11 1/2	1 1/2 - 11 1/2	2 - 11 1/2	2 - 11 1/2
5652-32323232	2 - 11 1/2	2 - 11 1/2	2 - 11 1/2	2 - 11 1/2	

6400

M-JIC / M-ORB

SAE# 070120

	PART NUMBER	T1	T2
	6400-0202	5/16 - 24	5/16 - 24
	6400-0303	3/8 - 24	3/8 - 24
	6400-0402	7/16 - 20	5/16 - 24
	6400-0403	7/16 - 20	3/8 - 24
	6400-0404	7/16 - 20	7/16 - 20
	6400-0405	7/16 - 20	1/2 - 20
	6400-0406	7/16 - 20	9/16 - 18
	6400-0408	7/16 - 20	3/4 - 16
	6400-0410	7/16 - 20	7/8 - 14
	6400-0412	7/16 - 20	1 1/16 - 12
	6400-0504	1/2 - 20	7/16 - 20
	6400-0505	1/2 - 20	1/2 - 20
	6400-0506	1/2 - 20	9/16 - 18
	6400-0604	9/16 - 18	7/16 - 20
	6400-0605	9/16 - 18	1/2 - 20
	6400-0606	9/16 - 18	9/16 - 18
	6400-0608	9/16 - 18	3/4 - 16
	6400-0610	9/16 - 18	7/8 - 14
	6400-0612	9/16 - 18	1 1/16 - 12
	6400-0804	3/4 - 16	7/16 - 24
	6400-0806	3/4 - 16	9/16 - 18
	6400-0808	3/4 - 16	3/4 - 16
	6400-0810	3/4 - 16	7/8 - 14
	6400-0812	3/4 - 16	1 1/16 - 12
	6400-0816	3/4 - 16	1 5/16 - 12
	6400-0820	3/4 - 16	1 5/8 - 12
	6400-1004	7/8 - 14	7/16 - 20
	6400-1006	7/8 - 14	9/16 - 18
	6400-1008	7/8 - 14	3/4 - 16
	6400-1010	7/8 - 14	7/8 - 14
	6400-1012	7/8 - 14	1 1/16 - 12
	6400-1016	7/8 - 14	1 5/16 - 12
	6400-1206	1 1/16 - 12	9/16 - 18
6400-1208	1 1/16 - 12	3/4 - 16	
6400-1210	1 1/16 - 12	7/8 - 14	
6400-1212	1 1/16 - 12	1 1/16 - 12	

ADAPTERS

6400

M-JIC / M-ORB (continued)

SAE# 070120

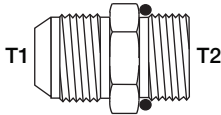

PART NUMBER	T1	T2
6400-1214	1 ¹ / ₁₆ - 12	1 ³ / ₁₆ - 12
6400-1216	1 ¹ / ₁₆ - 12	1 ⁵ / ₁₆ - 12
6400-1216	1 ¹ / ₁₆ - 12	1 ⁵ / ₁₆ - 12
6400-1220	1 ¹ / ₁₆ - 12	1 ⁵ / ₈ - 12
6400-1412	1 ³ / ₁₆ - 12	1 ¹ / ₁₆ - 12
6400-1414	1 ³ / ₁₆ - 12	1 ³ / ₁₆ - 12
6400-1416	1 ³ / ₁₆ - 12	1 ⁵ / ₁₆ - 12
6400-1608	1 ⁵ / ₁₆ - 12	3/4 - 16
6400-1610	1 ⁵ / ₁₆ - 12	7/8 - 14
6400-1612	1 ⁵ / ₁₆ - 12	1 ¹ / ₁₆ - 12
6400-1614	1 ⁵ / ₁₆ - 12	1 ³ / ₁₆ - 12
6400-1616	1 ⁵ / ₁₆ - 12	1 ⁵ / ₁₆ - 12
6400-1620	1 ⁵ / ₁₆ - 12	1 ⁵ / ₈ - 12
6400-1624	1 ⁵ / ₁₆ - 12	1 ⁷ / ₈ - 12
6400-2016	1 ⁵ / ₈ - 12	1 ⁵ / ₁₆ - 12
6400-2020	1 ⁵ / ₈ - 12	1 ⁵ / ₈ - 12
6400-2024	1 ⁵ / ₈ - 12	1 ⁷ / ₈ - 12
6400-2416	1 ⁷ / ₈ - 12	1 ⁵ / ₁₆ - 12
6400-2420	1 ⁷ / ₈ - 12	1 ⁵ / ₈ - 12
6400-2424	1 ⁷ / ₈ - 12	1 ⁷ / ₈ - 12
6400-2432	1 ⁷ / ₈ - 12	2 ¹ / ₂ - 12
6400-3220	2 ¹ / ₂ - 12	1 ⁵ / ₈ - 12
6400-3224	2 ¹ / ₂ - 12	1 ⁷ / ₈ - 12
6400-3232	2 ¹ / ₂ - 12	2 ¹ / ₂ - 12

6400L

M-JIC / M-ORB LONG



PART NUMBER	T1	T2
6400L-0404	7/16 - 20	7/16 - 20
6400L-0505	1/2 - 20	1/2 - 20
6400L-0606	9/16 - 18	9/16 - 18
6400L-0608	9/16 - 18	3/4 - 16
6400L-0808	3/4 - 16	3/4 - 16
6400L-1010	7/8 - 14	7/8 - 14
6400L-1212	1 ¹ / ₁₆ - 12	1 ¹ / ₁₆ - 12
6400L-1616	1 ⁵ / ₁₆ - 12	1 ⁵ / ₁₆ - 12
6400L-2020	1 ⁵ / ₈ - 12	1 ⁵ / ₈ - 12

ADAPTERS

6401 M-ORB / M-NPT

	PART NUMBER	T1	T2
		6401-0402	7/16 - 20
6401-0404		7/16 - 20	1/4 - 18
6401-0504		1/2 - 20	1/4 - 18
6401-0604		9/16 - 18	1/4 - 18
6401-0606		9/16 - 18	3/8 - 18
6401-0608		9/16 - 18	1/2 - 14
6401-0806		3/4 - 16	3/8 - 18
6401-0808		3/4 - 16	1/2 - 14
6401-0812		3/4 - 16	3/4 - 14
6401-1004		7/8 - 14	1/4 - 18
6401-1006		7/8 - 14	3/8 - 18
6401-1008		7/8 - 14	1/2 - 14
6401-1012		7/8 - 14	3/4 - 14
6401-1206		1 1/16 - 12	3/8 - 18
6401-1208		1 1/16 - 12	1/2 - 14
6401-1212		1 1/16 - 12	3/4 - 14
6401-1612		1 5/16 - 12	3/4 - 14
6401-1616		1 5/16 - 12	1 - 11 1/2
6401-2020		1 5/8 - 12	1 1/4 - 11 1/2
6401-2424		1 7/8 - 12	1 1/2 - 11 1/2
6401-3232	2 1/2 - 12	2 - 11 1/2	

6402 M-ORB / F-JIC

	PART NUMBER	T1	T2
		6402-0406	7/16 - 20
6402-0606		9/16 - 18	9/16 - 18
6402-0608		9/16 - 18	3/4 - 16
6402-0808		3/4 - 16	3/4 - 16
6402-1010		7/8 - 14	7/8 - 14
6402-1212		1 1/16 - 12	1 1/16 - 12
6402-1616		1 5/16 - 12	1 5/16 - 12
6402-2020		1 5/8 - 12	1 5/8 - 12
6402-2424		1 7/8 - 12	1 7/8 - 12
6402-3232		2 1/2 - 12	2 1/2 - 12

6404 F-ORB / M-NPT

	PART NUMBER	T1	T2
		6404-0402	7/16 - 20
6404-0404		7/16 - 20	1/4 - 18
6404-0406		7/16 - 20	3/8 - 18
6404-0502		1/2 - 20	1/8 - 27
6404-0604		9/16 - 18	1/4 - 18
6404-0606		9/16 - 18	3/8 - 18
6404-0608		9/16 - 18	1/2 - 14
6404-0806		3/4 - 16	3/8 - 18
6404-0808		3/4 - 16	1/2 - 14
6404-1008		7/8 - 14	1/2 - 14
6404-1212		1 1/16 - 12	3/4 - 14
6404-1616		1 5/16 - 12	1 - 11 1/2

ADAPTERS

6405

M-ORB / F-NPT

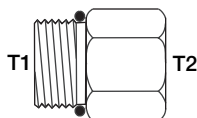

PART NUMBER	T1	T2
6405-0402	7/16 - 20	1/8 - 27
6405-0404	7/16 - 20	1/4 - 18
6405-0406	7/16 - 20	3/8 - 18
6405-0502	1/2 - 20	1/8 - 27
6405-0504	1/2 - 20	1/4 - 18
6405-0602	9/16 - 18	1/8 - 27
6405-0604	9/16 - 18	1/4 - 18
6405-0606	9/16 - 18	3/8 - 18
6405-0608	9/16 - 18	1/2 - 14
6405-0802	3/4 - 16	1/8 - 27
6405-0804	3/4 - 16	1/4 - 18
6405-0806	3/4 - 16	3/8 - 18
6405-0808	3/4 - 16	1/2 - 14
6405-0812	3/4 - 16	3/4 - 14
6405-1004	7/8 - 14	1/4 - 18
6405-1006	7/8 - 14	3/8 - 18
6405-1008	7/8 - 14	1/2 - 14
6405-1012	7/8 - 14	3/4 - 14
6405-1204	1 1/16 - 12	1/4 - 18
6405-1206	1 1/16 - 12	3/8 - 18
6405-1208	1 1/16 - 12	1/2 - 14
6405-1212	1 1/16 - 12	3/4 - 14
6405-1216	1 1/16 - 12	1 - 11 1/2
6405-1412	1 3/16 - 12	3/4 - 14
6405-1606	1 5/16 - 12	3/8 - 18
6405-1608	1 5/16 - 12	1/2 - 14
6405-1612	1 5/16 - 12	3/4 - 14
6405-1616	1 5/16 - 12	1 - 11 1/2
6405-1620	1 5/16 - 12	1 1/4 - 11 1/2
6405-2012	1 5/8 - 12	3/4 - 14
6405-2016	1 5/8 - 12	1 - 11 1/2
6405-2020	1 5/8 - 12	1 1/4 - 11 1/2
6405-2024	1 5/8 - 12	1 1/2 - 11 1/2
6405-2412	1 7/8 - 12	3/4 - 14
6405-2416	1 7/8 - 12	1 - 11 1/2
6405-2420	1 7/8 - 12	1 1/4 - 11 1/2
6405-2424	1 7/8 - 12	1 1/2 - 11 1/2
6405-3232	2 1/2 - 12	2 - 11 1/2

ADAPTERS

6408 ORB PLUG

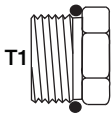
	PART NUMBER	T1
	6408-02	$\frac{5}{16}$ - 24
	6408-03	$\frac{3}{8}$ - 24
	6408-04	$\frac{7}{16}$ - 20
	6408-05	$\frac{1}{2}$ - 20
	6408-06	$\frac{9}{16}$ - 18
	6408-08	$\frac{3}{4}$ - 16
	6408-10	$\frac{7}{8}$ - 14
	6408-12	$1\frac{1}{16}$ - 12
	6408-14	$1\frac{3}{16}$ - 12
	6408-16	$1\frac{5}{16}$ - 12
	6408-20	$1\frac{5}{8}$ - 12
	6408-24	$1\frac{7}{8}$ - 12
	6408-32	$2\frac{1}{2}$ - 12

6408H ORB HOLLOW HEX PLUG

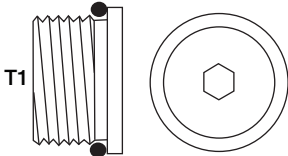
	PART NUMBER	T1
	6408H-02	$\frac{5}{16}$ - 24
	6408H-03	$\frac{3}{8}$ - 24
	6408H-04	$\frac{7}{16}$ - 20
	6408H-05	$\frac{1}{2}$ - 20
	6408H-06	$\frac{9}{16}$ - 18
	6408H-08	$\frac{3}{4}$ - 16
	6408H-10	$\frac{7}{8}$ - 14
	6408H-12	$1\frac{1}{16}$ - 12
	6408H-14	$1\frac{3}{16}$ - 12
	6408H-16	$1\frac{5}{16}$ - 12
	6408H-20	$1\frac{5}{8}$ - 12
	6408H-24	$1\frac{7}{8}$ - 12
	6408H-32	$2\frac{1}{2}$ - 12

ADAPTERS

6410

M-ORB / F-ORB

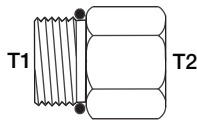

PART NUMBER	T1	T2
6410-0204	5/16 - 24	7/16 - 20
6410-0402	7/16 - 20	5/16 - 24
6410-0404	7/16 - 20	7/16 - 20
6410-0406	7/16 - 20	9/16 - 18
6410-0408	7/16 - 20	3/4 - 16
6410-0504	1/2 - 20	7/16 - 20
6410-0506	1/2 - 20	9/16 - 18
6410-0604	9/16 - 18	7/16 - 20
6410-0606	9/16 - 18	9/16 - 18
6410-0608	9/16 - 18	3/4 - 16
6410-0804	3/4 - 16	7/16 - 20
6410-0806	3/4 - 16	9/16 - 18
6410-0808	3/4 - 16	3/4 - 16
6410-0810	3/4 - 16	7/8 - 14
6410-0812	3/4 - 16	1 1/16 - 12
6410-1004	7/8 - 14	7/16 - 20
6410-1006	7/8 - 14	9/16 - 18
6410-1008	7/8 - 14	3/4 - 16
6410-1012	7/8 - 14	1 1/16 - 12
6410-1206	1 1/16 - 12	9/16 - 18
6410-1208	1 1/16 - 12	3/4 - 16
6410-1210	1 1/16 - 12	7/8 - 14
6410-1212	1 1/16 - 12	1 1/16 - 12
6410-1216	1 1/16 - 12	1 5/16 - 12
6410-1412	1 3/16 - 12	1 1/16 - 12
6410-1608	1 5/16 - 12	3/4 - 16
6410-1610	1 5/16 - 12	7/8 - 14
6410-1612	1 5/16 - 12	1 1/16 - 12
6410-1614	1 5/16 - 12	1 3/16 - 12
6410-1616	1 5/16 - 12	1 5/16 - 12
6410-1620	1 5/16 - 12	1 5/8 - 12
6410-2006	1 5/16 - 12	9/16 - 18
6410-2008	1 5/8 - 12	3/4 - 16
6410-2010	1 5/8 - 12	7/8 - 14
6410-2012	1 5/8 - 12	1 1/16 - 12
6410-2016	1 5/8 - 12	1 5/16 - 12
6410-2024	1 5/8 - 12	1 7/8 - 12
6410-2412	1 7/8 - 12	1 1/16 - 12
6410-2416	1 7/8 - 12	1 5/16 - 12
6410-2420	1 7/8 - 12	1 5/8 - 12
6410-3220	2 1/2 - 12	1 5/8 - 12
6410-3224	2 1/2 - 12	1 7/8 - 12

ADAPTERS

6464 M-ORB / M-ORB STRAIGHT

	PART NUMBER	T1	T2
	6464-0404	7/16 - 20	7/16 - 20
	6464-0808	3/4 - 16	3/4 - 16
	6464-1010	7/8 - 14	7/8 - 14
	6464-1616	1 5/16 - 12	1 5/16 - 12
	6464-2020	1 7/8 - 12	1 7/8 - 12

6500 90° M-JIC / F-JIC

SAE# 070221

	PART NUMBER	T1	T2
	6500-0202	5/16 - 24	5/16 - 24
	6500-0303	3/8 - 24	3/8 - 24
	6500-0404	7/16 - 20	7/16 - 20
	6500-0406	7/16 - 20	9/16 - 18
	6500-0505	1/2 - 20	1/2 - 20
	6500-0604	9/16 - 18	7/16 - 20
	6500-0606	9/16 - 18	9/16 - 18
	6500-0608	9/16 - 18	3/4 - 16
	6500-0806	3/4 - 16	9/16 - 18
	6500-0808	3/4 - 16	3/4 - 16
	6500-0810	3/4 - 16	7/8 - 14
	6500-0812	3/4 - 16	1 1/16 - 12
	6500-1008	7/8 - 14	3/4 - 16
	6500-1010	7/8 - 14	7/8 - 14
	6500-1012	7/8 - 14	1 1/16 - 12
	6500-1208	1 1/16 - 12	3/4 - 16
	6500-1210	1 1/16 - 12	7/8 - 14
	6500-1212	1 1/16 - 12	1 1/16 - 12
	6500-1216	1 1/16 - 12	1 5/16 - 12
	6500-1414	1 3/16 - 12	1 3/16 - 12
	6500-1612	1 5/16 - 12	1 1/16 - 12
	6500-1616	1 5/16 - 12	1 5/16 - 12
	6500-2020	1 7/8 - 12	1 7/8 - 12
	6500-2424	1 7/8 - 12	1 7/8 - 12
	6500-3232	2 1/2 - 12	2 1/2 - 12

ADAPTERS

6501 90° M-NPT / F-JIC

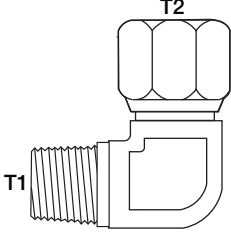
	PART NUMBER	T1	T2
	6501-0204	1/8 - 27	7/16 - 20
6501-0404	1/4 - 18	7/16 - 20	
6501-0406	1/4 - 18	9/16 - 18	
6501-0604	3/8 - 18	7/16 - 20	
6501-0606	3/8 - 18	9/16 - 18	
6501-0608	3/8 - 18	3/4 - 16	
6501-0806	1/2 - 14	9/16 - 18	
6501-0808	1/2 - 14	3/4 - 16	
6501-0810	1/2 - 14	7/8 - 14	
6501-1212	3/4 - 14	1 1/16 - 12	
6501-1214	3/4 - 14	1 3/16 - 12	
6501-1616	1 - 11 1/2	1 5/16 - 12	
6501-2020	1 1/4 - 11 1/2	1 5/8 - 12	
6501-2424	1 1/2 - 11 1/2	1 7/8 - 12	
6501-3232	2 - 11 1/2	2 1/2 - 12	

6502 45° M-JIC / F-JIC

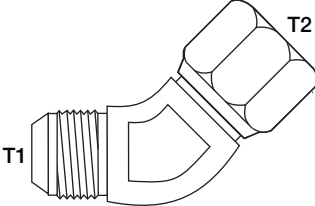
	PART NUMBER	T1	T2
	6502-0202	5/16 - 24	5/16 - 24
6502-0404	7/16 - 20	7/16 - 20	
6502-0505	1/2 - 20	1/2 - 20	
6502-0606	9/16 - 18	9/16 - 18	
6502-0808	3/4 - 16	3/4 - 16	
6502-1010	7/8 - 14	7/8 - 14	
6502-1212	1 1/16 - 12	1 1/16 - 12	
6502-1414	1 3/16 - 12	1 3/16 - 12	
6502-1616	1 5/16 - 12	1 5/16 - 12	
6502-2020	1 5/8 - 12	1 5/8 - 12	
6502-2424	1 7/8 - 12	1 7/8 - 12	
6502-3232	2 1/2 - 12	2 1/2 - 12	

6504 M-JIC / F-JIC STRAIGHT

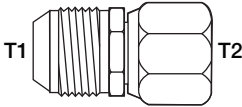
	PART NUMBER	T1	T2
	6504-0404	7/16 - 20	7/16 - 20
6504-0606	9/16 - 18	9/16 - 18	
6504-0808	3/4 - 16	3/4 - 16	
6504-1010	7/8 - 14	7/8 - 14	
6504-1212	1 1/16 - 12	1 1/16 - 12	
6504-1616	1 5/16 - 12	1 5/16 - 12	
6504-2020	1 5/8 - 12	1 5/8 - 12	

ADAPTERS

6505 M-NPT / F-JIC STRAIGHT

	PART NUMBER	T1	T2
	6505-0204	1/8 - 27	7/16 - 20
	6505-0404	1/4 - 18	7/16 - 20
	6505-0406	1/4 - 18	9/16 - 18
	6505-0606	3/8 - 18	9/16 - 18
	6505-0608	3/8 - 18	3/4 - 16
	6505-0808	1/2 - 14	3/4 - 16
	6505-0810	1/2 - 14	7/8 - 14
	6505-0812	1/2 - 14	1 1/16 - 12
	6505-1212	3/4 - 14	1 1/16 - 12
	6505-1616	1 - 11 1/2	1 5/16 - 12
	6505-2020	1 1/4 - 11 1/2	1 5/8 - 12
	6505-2424	1 1/2 - 11 1/2	1 7/8 - 12

6506 F-NPT / F-JIC STRAIGHT

	PART NUMBER	T1	T2
	6506-0404	1/4 - 18	7/16 - 20
	6506-0406	1/4 - 18	9/16 - 18
	6506-0606	3/8 - 18	9/16 - 18
	6506-0608	3/8 - 18	3/4 - 16
	6506-0806	1/2 - 14	9/16 - 18
	6506-0808	1/2 - 14	3/4 - 16
	6506-0810	1/2 - 14	7/8 - 14
	6506-1210	3/4 - 14	7/8 - 14
	6506-1212	3/4 - 14	1 1/16 - 12
	6506-1616	1 - 11 1/2	1 5/16 - 12
	6506-2020	1 1/4 - 11 1/2	1 5/8 - 12

6565 F-JIC / F-JIC STRAIGHT

	PART NUMBER	T1	T2
	6565-0404	7/16 - 20	7/16 - 20
	6565-0505	1/2 - 20	1/2 - 20
	6565-0604	9/16 - 18	7/16 - 20
	6565-0606	9/16 - 18	9/16 - 18
	6565-0806	3/4 - 16	9/16 - 18
	6565-0808	3/4 - 16	3/4 - 16
	6565-1008	7/8 - 14	3/4 - 16
	6565-1010	7/8 - 14	7/8 - 14
	6565-1212	1 1/16 - 12	1 1/16 - 12
	6565-1612	1 5/16 - 12	1 1/16 - 12
	6565-1616	1 5/16 - 12	1 5/16 - 12
	6565-2020	1 5/8 - 12	1 5/8 - 12
	6565-2424	1 7/8 - 12	1 7/8 - 12

ADAPTERS

6600

BRANCH TEE M-JIC / M-JIC / F-JIC

SAE# 070433

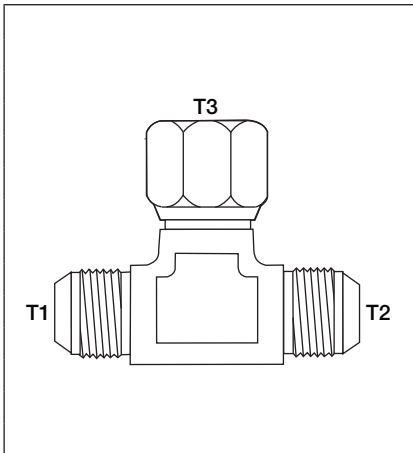

PART NUMBER	T1	T2	T3
6600-030303	3/8 - 24	3/8 - 24	3/8 - 24
6600-040404	7/16 - 24	7/16 - 24	7/16 - 24
6600-050505	1/2 - 20	1/2 - 20	1/2 - 20
6600-060606	9/16 - 18	9/16 - 18	9/16 - 18
6600-060608	9/16 - 18	9/16 - 18	3/4 - 16
6600-080808	3/4 - 16	3/4 - 16	3/4 - 16
6600-101010	7/8 - 14	7/8 - 14	7/8 - 14
6600-121212	1 1/16 - 12	1 1/16 - 12	1 1/16 - 12
6600-141414	1 3/16 - 12	1 3/16 - 12	1 3/16 - 12
6600-161616	1 5/16 - 12	1 5/16 - 12	1 5/16 - 12
6600-202020	1 5/8 - 12	1 5/8 - 12	1 5/8 - 12
6600-242424	1 7/8 - 12	1 7/8 - 12	1 7/8 - 12
6600-323232	2 1/2 - 12	2 1/2 - 12	2 1/2 - 12

6602

RUN TEE M-JIC / F-JIC / M-JIC

SAE# 070432

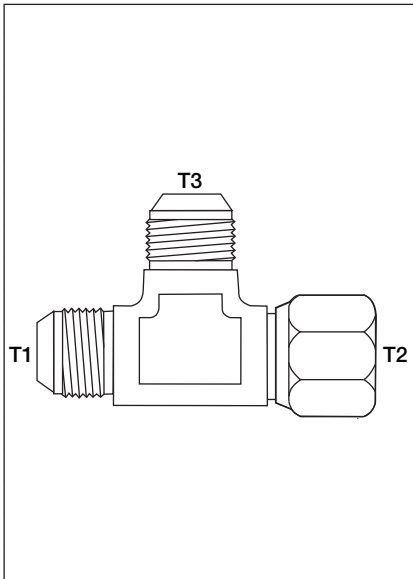

PART NUMBER	T1	T2	T3
6602-030303	3/8 - 24	3/8 - 24	3/8 - 24
6602-040404	7/16 - 24	7/16 - 24	7/16 - 24
6602-050505	1/2 - 20	1/2 - 20	1/2 - 20
6602-060604	9/16 - 18	9/16 - 18	7/16 - 20
6602-060606	9/16 - 18	9/16 - 18	9/16 - 18
6602-080806	3/4 - 16	3/4 - 16	9/16 - 18
6602-080808	3/4 - 16	3/4 - 16	3/4 - 16
6602-080812	3/4 - 16	3/4 - 16	1 1/16 - 12
6602-101010	7/8 - 14	7/8 - 14	7/8 - 14
6602-101012	7/8 - 14	7/8 - 14	1 1/16 - 12
6602-121212	1 1/16 - 12	1 1/16 - 12	1 1/16 - 12
6602-141414	1 3/16 - 12	1 3/16 - 12	1 3/16 - 12
6602-161610	1 5/16 - 12	1 5/16 - 12	7/8 - 14
6602-161616	1 5/16 - 12	1 5/16 - 12	1 5/16 - 12
6602-202020	1 5/8 - 12	1 5/8 - 12	1 5/8 - 12
6602-242424	1 7/8 - 12	1 7/8 - 12	1 7/8 - 12
6602-323232	2 1/2 - 12	2 1/2 - 12	2 1/2 - 12

6603

SWIVEL RUN TEE F-JIC/F-JIC/M-JIC

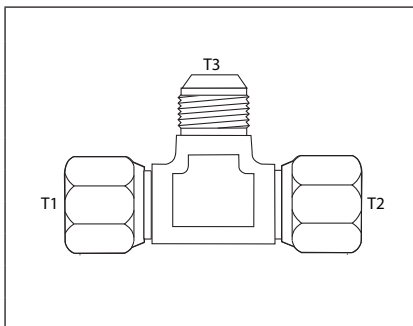

PART NUMBER	T1	T2	T2
6603-080808	3/4 - 16	3/4 - 16	3/4 - 16
6603-101010	7/8 - 14	7/8 - 14	7/8 - 14
6603-121212	1 1/16 - 12	1 1/16 - 12	1 1/16 - 12
6603-161616	1 5/16 - 12	1 5/16 - 12	1 5/16 - 12

ADAPTERS

6606 SWIVEL TEE F-JIC

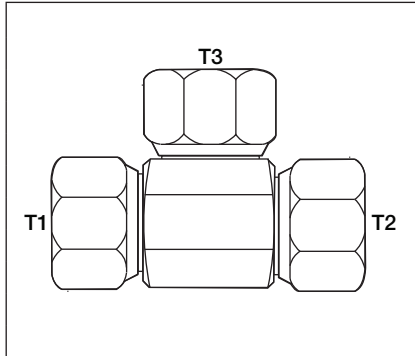

PART NUMBER	T1	T2	T2
6606-040404	7/16 - 20	7/16 - 20	7/16 - 20
6606-060606	9/16 - 18	9/16 - 18	9/16 - 18
6606-080808	3/4 - 16	3/4 - 16	3/4 - 16
6606-121212	1 1/16 - 12	1 1/16 - 12	1 1/16 - 12
6606-161616	1 5/16 - 12	1 5/16 - 12	1 5/16 - 12

6701 90° M-JIC / F-JIC BENT TUBE

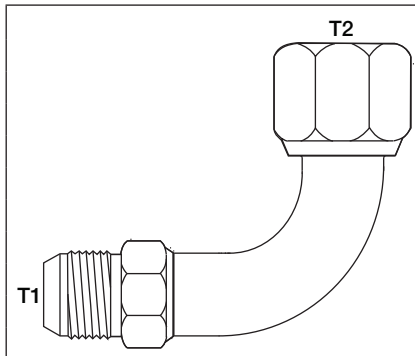

PART NUMBER	T1	T2
6701-0404	7/16 - 20	7/16 - 20
6701-0606	9/16 - 18	9/16 - 18
6701-0808	3/4 - 16	3/4 - 16
6701-1010	7/8 - 14	7/8 - 14
6701-1212	1 1/16 - 12	1 1/16 - 12
6701-1616	1 5/16 - 12	1 5/16 - 12
6701-2020	1 5/8 - 12	1 5/8 - 12

6701L 90° M-JIC / F-JIC BENT TUBE LONG

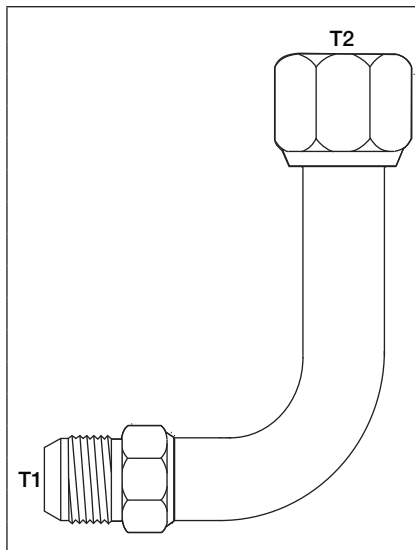

PART NUMBER	T1	T2
6701L-0404	7/16 - 20	7/16 - 20
6701L-0606	9/16 - 18	9/16 - 18
6701L-0808	3/4 - 16	3/4 - 16
6701L-1212	1 1/16 - 12	1 1/16 - 12
6701L-1616	1 5/16 - 12	1 5/16 - 12
6701L-2020	1 5/8 - 12	1 5/8 - 12

ADAPTERS

6801

90° M-JIC / M-ORB

SAE# 070220

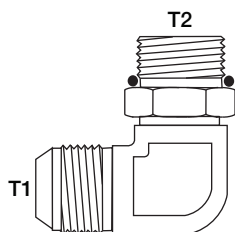

PART NUMBER	T1	T2
6801-0202	5/16 - 24	5/16 - 24
6801-0303	3/8 - 24	3/8 - 24
6801-0402	7/16 - 20	5/16 - 24
6801-0403	7/16 - 20	3/8 - 24
6801-0404	7/16 - 20	7/16 - 20
6801-0405	7/16 - 20	1/2 - 20
6801-0406	7/16 - 20	9/16 - 18
6801-0408	7/16 - 20	3/4 - 16
6801-0504	1/2 - 20	7/16 - 20
6801-0505	1/2 - 20	1/2 - 20
6801-0506	1/2 - 20	9/16 - 18
6801-0508	1/2 - 20	3/4 - 16
6801-0604	9/16 - 18	7/16 - 24
6801-0605	9/16 - 18	1/2 - 20
6801-0606	9/16 - 18	9/16 - 18
6801-0608	9/16 - 18	3/4 - 16
6801-0610	9/16 - 18	7/8 - 14
6801-0612	9/16 - 18	1 1/16 - 12
6801-0804	3/4 - 16	7/16 - 20
6801-0806	3/4 - 16	9/16 - 18
6801-0808	3/4 - 16	3/4 - 16
6801-0810	3/4 - 16	7/8 - 14
6801-0812	3/4 - 16	1 1/16 - 12
6801-0816	3/4 - 16	1 5/16 - 12
6801-1006	7/8 - 14	9/16 - 18
6801-1008	7/8 - 14	3/4 - 16
6801-1010	7/8 - 14	7/8 - 14
6801-1012	7/8 - 14	1 1/16 - 12
6801-1016	7/8 - 14	1 5/16 - 12
6801-1206	1 1/16 - 12	9/16 - 18
6801-1208	1 1/16 - 12	3/4 - 16
6801-1210	1 1/16 - 12	7/8 - 14
6801-1212	1 1/16 - 12	1 1/16 - 12
6801-1214	1 1/16 - 12	1 3/16 - 12
6801-1216	1 1/16 - 12	1 5/16 - 12
6801-1220	1 1/16 - 12	1 5/8 - 12
6801-1412	1 3/16 - 12	1 1/16 - 12
6801-1414	1 3/16 - 12	1 3/16 - 12
6801-1608	1 5/16 - 12	3/4 - 16
6801-1610	1 5/16 - 12	7/8 - 14
6801-1612	1 5/16 - 12	1 1/16 - 12
6801-1614	1 5/16 - 12	1 3/16 - 12
6801-1616	1 5/16 - 12	1 5/16 - 12
6801-1620	1 5/16 - 12	1 5/8 - 12
6801-1624	1 5/16 - 12	1 7/8 - 12

ADAPTERS

6801 **90° M-JIC / M-ORB** (continued) SAE# 070229

	PART NUMBER	T1	T2
	6801-2012	1 ⁵ / ₈ - 12	1 ¹ / ₁₆ - 12
	6801-2016	1 ⁵ / ₈ - 12	1 ⁵ / ₁₆ - 12
	6801-2020	1 ⁵ / ₈ - 12	1 ⁵ / ₈ - 12
	6801-2024	1 ⁵ / ₈ - 12	1 ⁷ / ₈ - 12
	6801-2416	1 ⁷ / ₈ - 12	1 ⁵ / ₁₆ - 12
	6801-2420	1 ⁷ / ₈ - 12	1 ⁵ / ₈ - 12
	6801-2424	1 ⁷ / ₈ - 12	1 ⁷ / ₈ - 12
	6801-3224	2 ¹ / ₂ - 12	1 ⁷ / ₈ - 12
	6801-3232	2 ¹ / ₂ - 12	2 ¹ / ₂ - 12

6801L **90° M-JIC / M-ORB LONG**

	PART NUMBER	T1	T2
	6801L-0404	7 ¹ / ₁₆ - 20	7 ¹ / ₁₆ - 20
	6801L-0406	7 ¹ / ₁₆ - 20	9 ¹ / ₁₆ - 18
	6801L-0606	9 ¹ / ₁₆ - 18	9 ¹ / ₁₆ - 18
	6801L-0608	9 ¹ / ₁₆ - 18	3 ⁴ / ₄ - 16
	6801L-0808	3 ⁴ / ₄ - 16	3 ⁴ / ₄ - 16
	6801L-0810	3 ⁴ / ₄ - 16	7 ⁸ / ₈ - 14
	6801L-1008	7 ⁸ / ₈ - 14	3 ⁴ / ₄ - 16
	6801L-1010	7 ⁸ / ₈ - 14	7 ⁸ / ₈ - 14
	6801L-1212	1 ¹ / ₁₆ - 12	1 ¹ / ₁₆ - 12
	6801L-1616	1 ⁵ / ₁₆ - 12	1 ⁵ / ₁₆ - 12

6801LL **90° M-JIC / M-ORB EXTRA LONG**

	PART NUMBER	T1	T2
	6801LL-0404	7 ¹ / ₁₆ - 20	7 ¹ / ₁₆ - 20
	6801LL-0606	9 ¹ / ₁₆ - 18	9 ¹ / ₁₆ - 18
	6801LL-0608	9 ¹ / ₁₆ - 18	3 ⁴ / ₄ - 16
	6801LL-0806	3 ⁴ / ₄ - 16	9 ¹ / ₁₆ - 18
	6801LL-0808	3 ⁴ / ₄ - 16	3 ⁴ / ₄ - 16
	6801LL-0810	3 ⁴ / ₄ - 16	7 ⁸ / ₈ - 14
	6801LL-1008	7 ⁸ / ₈ - 14	3 ⁴ / ₄ - 16
	6801LL-1010	7 ⁸ / ₈ - 14	7 ⁸ / ₈ - 14
	6801LL-1212	1 ¹ / ₁₆ - 12	1 ¹ / ₁₆ - 12
	6801LL-1216	1 ¹ / ₁₆ - 12	1 ⁵ / ₁₆ - 12
	6801LL-1612	1 ⁵ / ₁₆ - 12	1 ¹ / ₁₆ - 12
	6801LL-1616	1 ⁵ / ₁₆ - 12	1 ⁵ / ₁₆ - 12
	6801LL-2020	1 ⁵ / ₈ - 12	1 ⁵ / ₈ - 12

ADAPTERS

6803

BRANCH TEE M-JIC / M-JIC / M-ORB

SAE# 070429

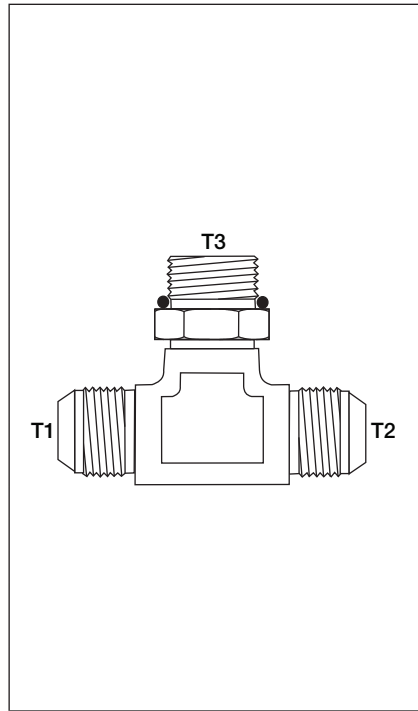

PART NUMBER	T1	T2	T3
6803-040404	7/16 - 20	7/16 - 20	7/16 - 20
6803-040406	7/16 - 20	7/16 - 20	9/16 - 18
6803-050505	1/2 - 20	1/2 - 20	1/2 - 20
6803-060604	9/16 - 18	9/16 - 18	7/16 - 20
6803-060606	9/16 - 18	9/16 - 18	9/16 - 18
6803-060608	9/16 - 18	9/16 - 18	3/4 - 16
6803-080806	3/4 - 16	3/4 - 16	9/16 - 18
6803-080808	3/4 - 16	3/4 - 16	3/4 - 16
6803-080810	3/4 - 16	3/4 - 16	7/8 - 14
6803-101010	7/8 - 14	7/8 - 14	7/8 - 14
6803-101012	7/8 - 14	7/8 - 14	1 1/16 - 12
6803-121208	1 1/16 - 12	1 1/16 - 12	3/4 - 16
6803-121210	1 1/16 - 12	1 1/16 - 12	7/8 - 14
6803-121212	1 1/16 - 12	1 1/16 - 12	1 1/16 - 12
6803-121216	1 1/16 - 12	1 1/16 - 12	1 5/16 - 12
6803-161216	1 5/16 - 12	1 1/16 - 12	1 5/16 - 12
6803-161612	1 5/16 - 12	1 5/16 - 12	1 1/16 - 12
6803-161616	1 5/16 - 12	1 5/16 - 12	1 5/16 - 12
6803-202020	1 5/8 - 12	1 5/8 - 12	1 5/8 - 12
6803-242424	1 7/8 - 12	1 7/8 - 12	1 7/8 - 12
6803-323232	2 1/2 - 12	2 1/2 - 12	2 1/2 - 12

6804

RUN TEE M-JIC / M-ORB / M-JIC

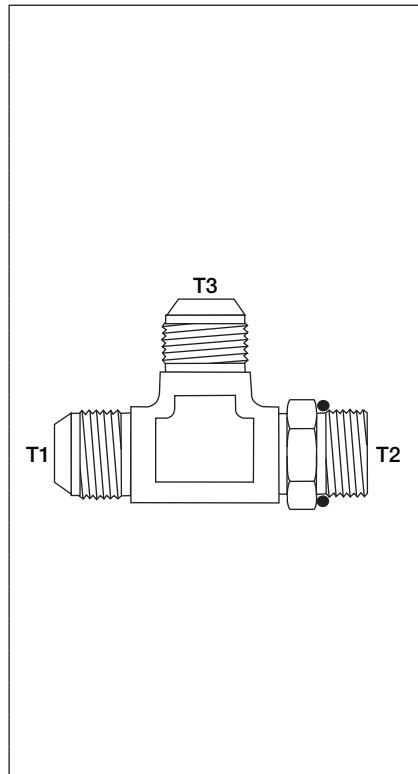

PART NUMBER	T1	T2	T3
6804-040404	7/16 - 20	7/16 - 20	7/16 - 20
6804-040604	7/16 - 20	7/16 - 20	7/16 - 20
6804-050505	1/2 - 20	1/2 - 20	1/2 - 20
6804-060406	9/16 - 18	7/16 - 20	9/16 - 18
6804-060606	9/16 - 18	9/16 - 18	9/16 - 18
6804-060806	9/16 - 18	3/4 - 16	9/16 - 18
6804-080608	3/4 - 16	9/16 - 18	3/4 - 16
6804-080804	3/4 - 16	3/4 - 16	7/16 - 20
6804-080808	3/4 - 16	3/4 - 16	3/4 - 16
6804-081008	3/4 - 16	7/8 - 14	3/4 - 16
6804-101010	7/8 - 14	7/8 - 14	7/8 - 14
6804-101210	7/8 - 14	1 1/16 - 12	7/8 - 14
6804-121012	1 1/16 - 12	7/8 - 14	1 1/16 - 12
6804-121208	1 1/16 - 12	1 1/16 - 12	3/4 - 16
6804-121212	1 1/16 - 12	1 1/16 - 12	1 1/16 - 12
6804-121216	1 1/16 - 12	1 1/16 - 12	1 5/16 - 12
6804-121612	1 1/16 - 12	1 5/16 - 12	1 1/16 - 12
6804-161216	1 5/16 - 12	1 1/16 - 12	1 5/16 - 12
6804-161612	1 5/16 - 12	1 5/16 - 12	1 1/16 - 12
6804-161616	1 5/16 - 12	1 5/16 - 12	1 5/16 - 12
6804-202020	1 5/8 - 12	1 5/8 - 12	1 5/8 - 12
6804-242424	1 7/8 - 12	1 7/8 - 12	1 7/8 - 12
6804-323232	2 1/2 - 12	2 1/2 - 12	2 1/2 - 12

ADAPTERS

6805

90° M-ORB / F-NPT

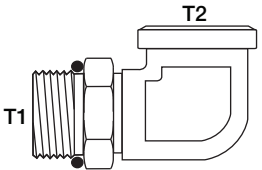
	PART NUMBER	T1	T2
	6805-0402	7/16 - 20	1/8 - 27
6805-0404	7/16 - 20	1/4 - 18	
6805-0406	7/16 - 20	3/8 - 18	
6805-0502	1/2 - 20	1/8 - 27	
6805-0604	9/16 - 18	1/4 - 18	
6805-0606	9/16 - 18	3/8 - 18	
6805-0806	3/4 - 16	3/8 - 18	
6805-0808	3/4 - 16	1/2 - 14	
6805-1006	7/8 - 14	3/8 - 18	
6805-1008	7/8 - 14	1/2 - 14	
6805-1208	1 1/16 - 12	1/2 - 14	
6805-1212	1 1/16 - 12	3/4 - 14	
6805-1412	1 3/16 - 12	3/4 - 14	
6805-1612	1 5/16 - 12	3/4 - 14	
6805-1616	1 5/16 - 12	1 - 11 1/2	
6805-2020	1 5/8 - 12	1 1/4 - 11 1/2	
6805-2424	1 7/8 - 12	1 1/2 - 11 1/2	
6805-3232	2 1/2 - 12	2 - 11 1/2	

6805L

90° M-ORB / F-NPT LONG

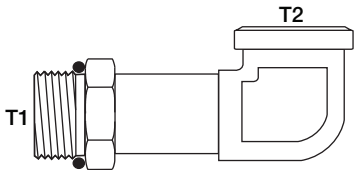
	PART NUMBER	T1	T2
	6805L-0808	3/4 - 16	1/2 - 14
6805L-1008	7/8 - 14	1/2 - 14	
6805L-1212	1 1/16 - 12	3/4 - 14	
6805L-1616	1 5/16 - 12	1 - 11 1/2	

6806

90° M-ORB / M-NPT

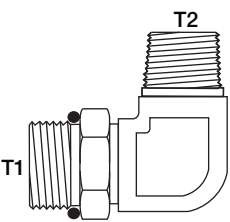
	PART NUMBER	T1	T2
	6806-0402	7/16 - 20	1/8 - 27
6806-0404	7/16 - 20	1/4 - 18	
6806-0502	1/2 - 20	1/8 - 27	
6806-0604	9/16 - 18	1/4 - 18	
6806-0606	9/16 - 18	3/8 - 18	
6806-0806	3/4 - 16	3/8 - 18	
6806-0808	3/4 - 16	1/2 - 14	
6806-1008	7/8 - 14	1/2 - 14	
6806-1212	1 1/16 - 12	3/4 - 14	
6806-1412	1 3/16 - 12	3/4 - 14	
6806-1612	1 5/16 - 12	3/4 - 14	
6806-1616	1 5/16 - 12	1 - 11 1/2	
6806-2020	1 5/8 - 12	1 1/4 - 11 1/2	
6806-2424	1 7/8 - 12	1 1/2 - 11 1/2	
6806-3232	2 1/2 - 12	2 - 11 1/2	

ADAPTERS

6807 90° M-ORB /M-ORB

	PART NUMBER	T1	T2
	6807-0404	7/16 - 20	7/16 - 20
	6807-0606	9/16 - 18	9/16 - 18
	6807-0806	3/4 - 16	9/16 - 18
	6807-0808	3/4 - 16	3/4 - 16
	6807-1008	7/8 - 14	3/4 - 16
	6807-1010	7/8 - 14	7/8 - 14
	6807-1212	1 1/16 - 12	1 1/16 - 12
	6807-1616	1 5/16 - 12	1 5/16 - 12
	6807-2020	1 5/8 - 12	1 5/8 - 12
	6807-2424	1 7/8 - 12	1 7/8 - 12

6809 90° M-ORB /F-JIC

	PART NUMBER	T1	T2
	6809-0404	7/16 - 20	7/16 - 20
	6809-0604	9/16 - 18	7/16 - 20
	6809-0606	9/16 - 18	9/16 - 18
	6809-0806	3/4 - 16	9/16 - 18
	6809-0808	3/4 - 16	3/4 - 16
	6809-1010	7/8 - 14	7/8 - 14
	6809-1210	1 1/16 - 12	7/8 - 14
	6809-1212	1 1/16 - 12	1 1/16 - 12
	6809-1616	1 5/16 - 12	1 5/16 - 12
	6809-2020	1 5/8 - 12	1 5/8 - 12

6815 90° M-ORB /F-ORB

	PART NUMBER	T1	T2
	6815-0404	7/16 - 20	7/16 - 20
	6815-0606	9/16 - 18	9/16 - 18
	6815-0808	3/4 - 16	3/4 - 16
	6815-1010	7/8 - 14	7/8 - 14
	6815-1212	1 1/16 - 12	1 1/16 - 12
	6815-1616	1 5/16 - 12	1 5/16 - 12

ADAPTERS

6900

M-ORB / F-NPSM

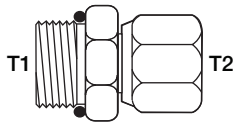

PART NUMBER	T1	T2
6900-0404	7/16 - 20	1/4 - 18
6900-0406	7/16 - 20	3/8 - 18
6900-0504	1/2 - 20	1/4 - 18
6900-0604	9/16 - 18	1/4 - 18
6900-0606	9/16 - 18	3/8 - 18
6900-0608	9/16 - 18	1/2 - 14
6900-0804	3/4 - 16	1/4 - 18
6900-0806	3/4 - 16	3/8 - 18
6900-0808	3/4 - 16	1/2 - 14
6900-0812	3/4 - 16	3/4 - 14
6900-1006	7/8 - 14	3/8 - 18
6900-1008	7/8 - 14	1/2 - 14
6900-1012	7/8 - 14	3/4 - 14
6900-1206	1 1/16 - 12	3/8 - 18
6900-1208	1 1/16 - 12	1/2 - 14
6900-1212	1 1/16 - 12	3/4 - 14
6900-1216	1 1/16 - 12	1 - 11 1/2
6900-1412	1 3/16 - 12	3/4 - 14
6900-1612	1 5/16 - 12	3/4 - 14
6900-1616	1 5/16 - 12	1 - 11 1/2
6900-1620	1 5/16 - 12	1 1/4 - 11 1/2
6900-2016	1 5/8 - 12	1 - 11 1/2
6900-2020	1 5/8 - 12	1 1/4 - 11 1/2
6900-2424	1 7/8 - 12	1 1/2 - 11 1/2
6900-3232	2 1/2 - 12	2 - 11 1/2

6901

90° M-ORB / F-NPSM

SAE# 140257

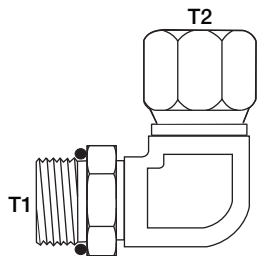

PART NUMBER	T1	T2
6901-0404	7/16 - 20	1/4 - 18
6901-0406	7/16 - 20	3/8 - 18
6901-0604	9/16 - 18	1/4 - 18
6901-0606	9/16 - 18	3/8 - 18
6901-0608	9/16 - 18	1/2 - 14
6901-0804	3/4 - 16	1/4 - 18
6901-0806	3/4 - 16	3/8 - 18
6901-0808	3/4 - 16	1/2 - 14
6901-0812	3/4 - 16	3/4 - 14
6901-1006	7/8 - 14	3/8 - 18
6901-1008	7/8 - 14	1/2 - 14
6901-1012	7/8 - 14	3/4 - 14
6901-1206	1 1/16 - 12	3/8 - 18
6901-1208	1 1/16 - 12	1/2 - 14
6901-1212	1 1/16 - 12	3/4 - 14
6901-1216	1 1/16 - 12	1 - 11 1/2
6901-1412	1 3/16 - 12	3/4 - 14
6901-1612	1 5/16 - 12	3/4 - 14
6901-1616	1 5/16 - 12	1 - 11 1/2
6901-1620	1 5/16 - 12	1 1/4 - 11 1/2
6901-2012	1 5/8 - 12	3/4 - 14
6901-2016	1 5/8 - 12	1 - 11 1/2
6901-2020	1 5/8 - 12	1 1/4 - 11 1/2
6901-2420	1 7/8 - 12	1 1/4 - 11 1/2
6901-2424	1 7/8 - 12	1 1/2 - 11 1/2
6901-3232	2 1/2 - 12	2 - 11 1/2

6902

45° M-ORB / F-NPSM

SAE# 140357

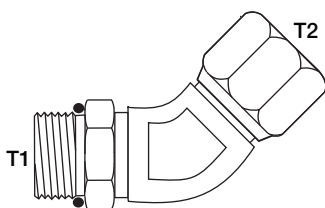

PART NUMBER	T1	T2
6902-0404	7/16 - 20	1/4 - 18
6902-0604	9/16 - 18	1/4 - 18
6902-0606	9/16 - 18	3/8 - 18
6902-0608	9/16 - 18	1/2 - 14
6902-0806	3/4 - 16	3/8 - 18
6902-0808	3/4 - 16	1/2 - 14
6902-0812	3/4 - 16	3/4 - 14
6902-1006	7/8 - 14	3/8 - 18
6902-1008	7/8 - 14	1/2 - 14
6902-1012	7/8 - 14	3/4 - 14
6902-1206	1 1/16 - 12	3/8 - 18
6902-1208	1 1/16 - 12	1/2 - 14
6902-1212	1 1/16 - 12	3/4 - 14
6902-1616	1 5/16 - 12	1 - 11 1/2
6902-2020	1 5/8 - 12	1 1/4 - 11 1/2
6902-2424	1 7/8 - 12	1 1/2 - 11 1/2

ADAPTERS

7000

M-JIC / M-BSPT STRAIGHT

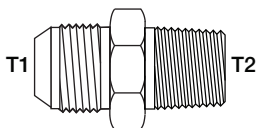

PART NUMBER	T1	T2
7000-0402	7/16 - 20	1/8 - 28
7000-0404	7/16 - 20	1/4 - 19
7000-0406	7/16 - 20	3/8 - 19
7000-0604	9/16 - 18	1/4 - 19
7000-0606	9/16 - 18	3/8 - 19
7000-0608	9/16 - 18	1/2 - 14
7000-0806	3/4 - 16	3/8 - 19
7000-0808	3/4 - 16	1/2 - 14
7000-1006	7/8 - 14	3/8 - 19
7000-1008	7/8 - 14	1/2 - 14
7000-1212	1 1/16 - 12	3/4 - 14
7000-1612	1 5/16 - 12	3/4 - 14
7000-1616	1 5/16 - 12	1 - 11

7002

M-JIC / M-BSPP STRAIGHT

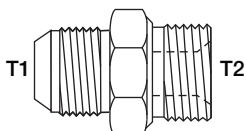

PART NUMBER	T1	T2
7002-0402	7/16 - 20	1/8 - 28
7002-0404	7/16 - 20	1/4 - 19
7002-0406	7/16 - 20	3/8 - 19
7002-0408	7/16 - 20	1/2 - 14
7002-0602	9/16 - 18	1/8 - 28
7002-0604	9/16 - 18	1/4 - 19
7002-0606	9/16 - 18	3/8 - 19
7002-0608	9/16 - 18	1/2 - 14
7002-0610	9/16 - 18	5/8 - 14
7002-0804	3/4 - 16	1/4 - 19
7002-0806	3/4 - 16	3/8 - 19
7002-0808	3/4 - 16	1/2 - 14
7002-0810	3/4 - 16	5/8 - 14
7002-0812	3/4 - 16	3/4 - 14
7002-0816	3/4 - 16	1 - 11
7002-1006	7/8 - 14	3/8 - 19
7002-1008	7/8 - 14	1/2 - 14
7002-1010	7/8 - 14	5/8 - 14
7002-1012	7/8 - 14	3/4 - 14
7002-1208	1 1/16 - 12	1/2 - 14
7002-1210	1 1/16 - 12	5/8 - 14
7002-1212	1 1/16 - 12	3/4 - 14
7002-1216	1 1/16 - 12	1 - 11
7002-1220	1 1/16 - 12	1 1/4 - 11
7002-1608	1 5/16 - 12	1/2 - 14
7002-1612	1 5/16 - 12	3/4 - 14
7002-1616	1 5/16 - 12	1 - 11
7002-1620	1 5/16 - 12	1 1/4 - 11
7002-2016	1 5/8 - 12	1 - 11
7002-2020	1 5/8 - 12	1 1/4 - 11
7002-2024	1 5/8 - 12	1 1/2 - 11
7002-2424	1 7/8 - 12	1 1/2 - 11

ADAPTERS

7004 M-JIC / F-BSP

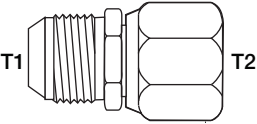
	PART NUMBER	T1	T2
	7004-0402	7/16 - 20	1/8 - 28
	7004-0404	7/16 - 20	1/4 - 19
	7004-0406	7/16 - 20	3/8 - 19
	7004-0408	7/16 - 20	1/2 - 14
	7004-0604	9/16 - 18	1/4 - 19
	7004-0606	9/16 - 18	3/8 - 19
	7004-0608	9/16 - 18	1/2 - 14
	7004-0806	3/4 - 16	3/8 - 19
	7004-0808	3/4 - 16	1/2 - 14
	7004-0810	3/4 - 16	5/8 - 14
	7004-0812	3/4 - 16	3/4 - 14
	7004-1008	7/8 - 14	1/2 - 14
	7004-1012	7/8 - 14	3/4 - 14
	7004-1212	1 1/16 - 12	3/4 - 14
	7004-1216	1 1/16 - 12	1 - 11
7004-1616	1 5/16 - 12	1 - 11	

7005 M-JIC / M-METRIC PORT

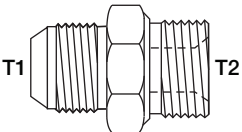
	PART NUMBER	T1	T2
	7005-0412	7/16 - 20	M12 x 1.5
	7005-0414	7/16 - 20	M14 x 1.5
	7005-0614	9/16 - 18	M14 x 1.5
	7005-0616	9/16 - 18	M16 x 1.5
	7005-0618	9/16 - 18	M18 x 1.5
	7005-0620	9/16 - 18	M20 x 1.5
	7005-0820	3/4 - 16	M20 x 1.5
	7005-0822	3/4 - 16	M22 x 1.5
	7005-1226	1 1/16 - 12	M26 x 1.5

7005L M-JIC / M-METRIC LIGHT

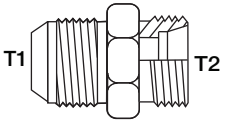
	PART NUMBER	T1	T2
	7005L-0412	7/16 - 24	M12 x 1.5
	7005L-0414	7/16 - 20	M14 x 1.5
	7005L-0616	9/16 - 18	M16 x 1.5
	7005L-0618	9/16 - 18	M18 x 1.5
	7005L-0816	3/4 - 16	M16 x 1.5
	7005L-0818	3/4 - 16	M18 x 1.5
	7005L-1022	7/8 - 14	M22 x 1.5
	7005L-1222	1 1/16 - 12	M22 x 1.5
	7005L-1226	1 1/16 - 12	M26 x 1.5
	7005L-1230	1 1/16 - 12	M30 x 2.0
	7005L-1636	1 5/16 - 12	M36 x 2.0
	7005L-2045	1 5/8 - 12	M45 x 2.0

ADAPTERS

7005S M-JIC / M-METRIC HEAVY

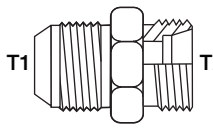
	PART NUMBER	T1	T2
		7005S-0416	7/16 - 20
	7005S-0618	9/16 - 18	M18 x 1.5
	7005S-0620	9/16 - 18	M20 x 1.5
	7005S-0818	3/4 - 16	M18 x 1.5
	7005S-0820	3/4 - 16	M20 x 1.5
	7005S-0822	3/4 - 16	M22 x 1.5
	7005S-1024	7/8 - 14	M24 x 1.5
	7005S-1230	1 1/16 - 12	M30 x 2.0
	7005S-1236	1 1/16 - 12	M36 x 2.0
	7005S-1642	1 5/16 - 12	M42 x 2.0
	7005S-2052	1 5/8 - 12	M52 x 2.0

7009 M-JIC / M-KOMATSU

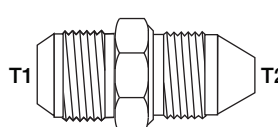
	PART NUMBER	T1	T2
		7009-0414	7/16 - 20
	7009-0618	9/16 - 18	M18 x 1.5
	7009-0822	3/4 - 16	M22 x 1.5
	7009-1024	7/8 - 14	M24 x 1.5
	7009-1230	1 1/16 - 12	M30 x 1.5
	7009-1633	1 5/16 - 12	M33 x 1.5

7022 F-JIC SWIVEL / M-BSP

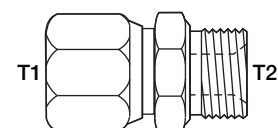
	PART NUMBER	T1	T2
		7022-0404	7/16 - 20
	7022-0406	9/16 - 18	1/4 - 19
	7022-0606	9/16 - 18	3/8 - 19
	7022-0808	3/4 - 16	1/2 - 14
	7022-1212	1 1/16 - 12	3/4 - 14
	7022-1616	1 5/16 - 12	1 - 11

ADAPTERS

7032 M-NPT / M-BSPP

	PART NUMBER	T1	T2
		7032-0202	1/8 - 28
7032-0402		1/4 - 19	1/8 - 27
7032-0404		1/4 - 19	1/4 - 18
7032-0406		1/4 - 19	3/8 - 18
7032-0408		1/4 - 19	1/2 - 14
7032-0604		3/8 - 19	1/4 - 18
7032-0606		3/8 - 19	3/8 - 18
7032-0608		3/8 - 19	1/2 - 14
7032-0804		1/2 - 14	1/4 - 18
7032-0806		1/2 - 14	3/8 - 18
7032-0808		1/2 - 14	1/2 - 14
7032-0812		1/2 - 14	3/4 - 14
7032-1008		5/8 - 14	1/2 - 14
7032-1208		3/4 - 14	1/2 - 14
7032-1212		3/4 - 14	3/4 - 14
7032-1216		3/4 - 14	1 - 11 1/2
7032-1612		1 - 11	3/4 - 14
7032-1616		1 - 11	1 - 11 1/2
7032-2020		1 1/4 - 11	1 1/4 - 11 1/2
7032-2424		1 1/2 - 11	1 1/2 - 11 1/2
7032-3232	2 - 11	2 - 11 1/2	

7062 M-ORB / M-BSPP

	PART NUMBER	T1	T2
		7062-0404	7/16 - 20
7062-0406		7/16 - 20	3/8 - 19
7062-0604		9/16 - 18	1/4 - 19
7062-0606		9/16 - 18	3/8 - 19
7062-0608		9/16 - 18	1/2 - 14
7062-0806		3/4 - 16	3/8 - 19
7062-0808		3/4 - 16	1/2 - 14
7062-1006		7/8 - 14	3/8 - 19
7062-1008		7/8 - 14	1/2 - 14
7062-1212		1 1/16 - 12	3/4 - 14
7062-1616		1 5/16 - 12	1 - 11

ADAPTERS

7102 45° M-JIC / M-BSP

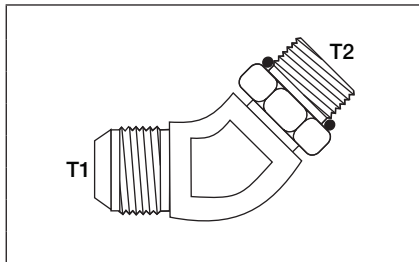

PART NUMBER	T1	T2
7102-0404	7/16 - 20	1/4 - 19
7102-0606	9/16 - 18	3/8 - 19
7102-0808	3/4 - 16	1/2 - 14
7102-1212	1 1/16 - 12	3/4 - 14
7102-1616	1 5/16 - 12	1 - 11

7202 90° M-JIC / M-BSP

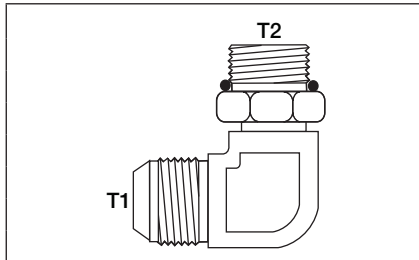

PART NUMBER	T1	T2
7202-0404	7/16 - 20	1/4 - 19
7202-0606	9/16 - 18	3/8 - 19
7202-0808	3/4 - 16	1/2 - 14
7202-1212	1 1/16 - 12	3/4 - 14
7202-1616	1 5/16 - 12	1 - 11

7204 90° M-JIC / F-BSP

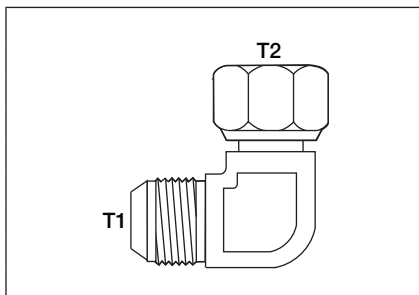

PART NUMBER	T1	T2
7204-0606	9/16 - 18	3/8 - 19
7204-0808	3/4 - 16	1/2 - 14
7204-1212	1 1/16 - 12	3/4 - 14

7205 90° M-JIC / M-METRIC

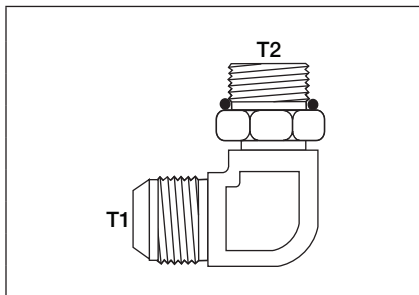

PART NUMBER	T1	T2
7205-0412	7/16 - 20	M12 x 1.5
7205-0614	9/16 - 18	M14 x 1.5
7205-0818	3/4 - 16	M18 x 1.5
7205-1020	7/8 - 14	M20 x 1.5
7205-1222	1 1/16 - 12	M22 x 1.5

ADAPTERS

7222 F-JIC / 90° M-BSPP

	PART NUMBER	T1	T2
	7222-0202	1/8 - 28	1/8 - 28
	7222-0404	1/4 - 19	1/4 - 19
	7222-0606	3/8 - 19	3/8 - 19
	7222-0808	1/2 - 14	1/2 - 14
	7222-1212	3/4 - 14	3/4 - 14
	7222-1616	1 - 11	1 - 11
	7222-2020	1 1/4 - 11	1 1/4 - 11

7588P JIS PLUG

	PART NUMBER	T1
	7588P-04	1/4 - 19
	7588P-06	3/8 - 19
	7588P-08	1/2 - 14
	7588P-12	3/4 - 14
	7588P-16	1 - 11

7599P KOMATSU PLUG

	PART NUMBER	T1
	7599P-14	M14 x 1.5
	7599P-18	M18 x 1.5
	7599P-22	M22 x 1.5
	7599P-24	M24 x 1.5
	7599P-30	M30 x 1.5
	7599P-33	M33 x 1.5
	7599P-42	M42 x 1.5

7688C JIS CAP

	PART NUMBER	T1
	7688C-04	1/4 - 19
	7688C-06	3/8 - 19
	7688C-08	1/2 - 14
	7688C-12	3/4 - 14
	7688C-16	1 - 11

8800 METRIC BONDED SEAL

	PART NUMBER	T1
	8800-12	M12
	8800-14	M14
	8800-16	M16
	8800-18	M18
	8800-22	M22
	8800-26	M26
	8800-30	M30

ADAPTERS

9020

M-BSPP / M-BSPT STRAIGHT

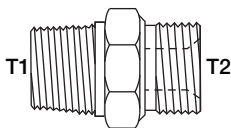

PART NUMBER	T1	T2
9020-0202	1/8 - 28	1/8 - 28
9020-0204	1/8 - 28	1/4 - 19
9020-0206	1/8 - 28	3/8 - 19
9020-0404	1/4 - 19	1/4 - 19
9020-0406	1/4 - 19	3/8 - 19
9020-0604	3/8 - 19	1/4 - 19
9020-0606	3/8 - 19	3/8 - 19
9020-0608	3/8 - 19	1/2 - 14
9020-0804	1/2 - 14	1/4 - 19
9020-0806	1/2 - 14	3/8 - 19
9020-0808	1/2 - 14	1/2 - 14
9020-0812	1/2 - 14	3/4 - 14
9020-1008	5/8 - 14	1/2 - 14
9020-1208	3/4 - 14	1/2 - 14
9020-1212	3/4 - 14	3/4 - 14
9020-1216	3/4 - 14	1 - 11
9020-1612	1 - 11	3/4 - 14
9020-1616	1 - 11	1 - 11
9020-2020	1 1/4 - 11	1 1/4 - 11

9022

M-BSPP / M-BSPP STRAIGHT

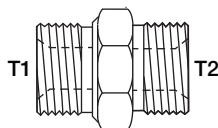

PART NUMBER	T1	T2
9022-0202	1/8 - 28	1/8 - 28
9022-0402	1/4 - 19	1/8 - 28
9022-0404	1/4 - 19	1/4 - 19
9022-0604	3/8 - 19	1/4 - 19
9022-0606	3/8 - 19	3/8 - 19
9022-0804	1/2 - 14	1/4 - 19
9022-0806	1/2 - 14	3/8 - 19
9022-0808	1/2 - 14	1/2 - 14
9022-1010	5/8 - 14	5/8 - 14
9022-1208	3/4 - 14	1/2 - 14
9022-1212	3/4 - 14	3/4 - 14
9022-1612	1 - 11	3/4 - 14
9022-1616	1 - 11	1 - 11
9022-2016	1 1/4 - 11	1 - 11
9022-2020	1 1/4 - 11	1 1/4 - 11
9022-2424	1 1/2 - 11	1 1/2 - 11
9022-3232	2 - 11	2 - 11

ADAPTERS

9023 M-BSPP / F-BSPP

	PART NUMBER	T1	T2
	9023-0602	3/8 - 19	1/8 - 28
	9023-0804	1/2 - 14	1/4 - 19
	9023-1204	3/4 - 14	1/4 - 19
	9023-1206	3/4 - 14	3/8 - 19
	9023-1606	1 - 11	3/8 - 19
	9023-1608	1 - 11	1/2 - 14
	9023-2012	1 1/4 - 11	3/4 - 14
9023-2016	1 1/4 - 11	1 - 11	

9024 M-BSPP / F-BSPP

	PART NUMBER	T1	T2
	9024-0202	1/8 - 28	1/8 - 28
	9024-0404	1/4 - 19	1/4 - 19
	9024-0606	3/8 - 19	3/8 - 19
	9024-0808	1/2 - 14	1/2 - 14
	9024-1010	5/8 - 14	5/8 - 14
	9024-1212	3/4 - 14	3/4 - 14
	9024-1616	1 - 11	1 - 11

9087 BRANCH TEE M-BSPP / M-BSPP / F-BSPP

	PART NUMBER	T1	T2	T3
	9087-040404	1/4 - 19	1/4 - 19	1/4 - 19
	9087-060606	3/8 - 19	3/8 - 19	3/8 - 19
	9087-080808	1/2 - 14	1/2 - 14	1/2 - 14
	9087-121212	3/4 - 14	3/4 - 14	3/4 - 14
	9087-161616	1 - 11	1 - 11	1 - 11

9090 RUN TEE M-BSPP / F-BSPP / M-BSPP

	PART NUMBER	T1	T2	T3
	9090-040404	1/4 - 19	1/4 - 19	1/4 - 19
	9090-060606	3/8 - 19	3/8 - 19	3/8 - 19
	9090-080808	1/2 - 14	1/2 - 14	1/2 - 14
	9090-121212	3/4 - 14	3/4 - 14	3/4 - 14
	9090-161616	1 - 11	1 - 11	1 - 11

ADAPTERS

9124 45° M-BSP / F-BSP BENT TUBE

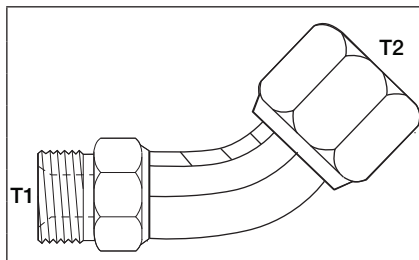

PART NUMBER	T1	T2
9124-0404	1/4 - 19	1/4 - 19
9124-0606	3/8 - 19	3/8 - 19
9124-0808	1/2 - 14	1/2 - 14
9124-1212	3/4 - 14	3/4 - 14
9124-1616	1 - 11	1 - 11

9224L 90° M-BSP / F-BSP BENT TUBE

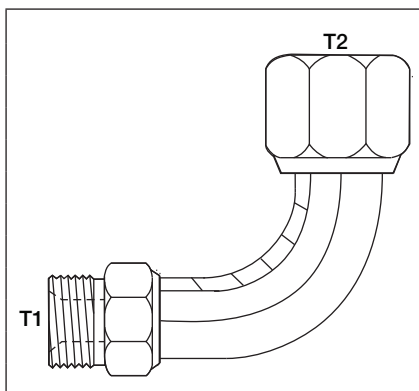

PART NUMBER	T1	T2
9224L-0404	1/4 - 19	1/4 - 19
9224L-0606	3/8 - 19	3/8 - 19
9224L-0808	1/2 - 14	1/2 - 14
9224L-1212	3/4 - 14	3/4 - 14
9224L-1616	1 - 11	1 - 11

9245 M-JIC / M-JSW

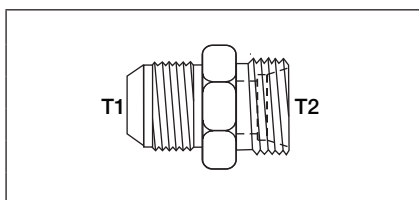

PART NUMBER	T1	T2
9245-12-34	1 1/16 - 12	M34 x 1.5
9245-16-40	1 5/16 - 12	M40 x 1.5
9245-20-48	1 5/8 - 12	M48 x 1.5

9247 M-JIC / M-KOBELCO

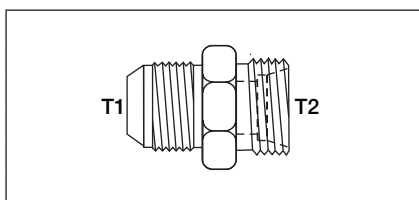

PART NUMBER	T1	T2
9247-12-36	1 1/16 - 12	M36 x 1.5
9247-16-36	1 5/16 - 12	M36 x 1.5
9247-16-45	1 5/16 - 12	M45 x 1.5
9247-20-45	1 5/8 - 12	M45 x 1.5

9322 TEE M-BSP

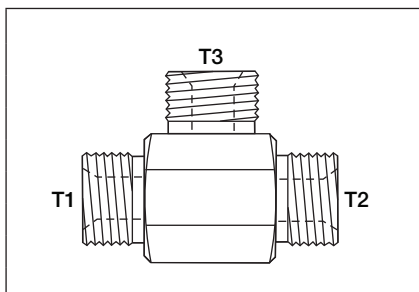

PART NUMBER	T1	T2	T3
9322-040404	1/4 - 19	1/4 - 19	1/4 - 19
9322-060606	3/8 - 19	3/8 - 19	3/8 - 19
9322-080808	1/2 - 14	1/2 - 14	1/2 - 14
9322-121212	3/4 - 14	3/4 - 14	3/4 - 14
9322-161616	1 - 11	1 - 11	1 - 11
9322-202020	1 1/4 - 11	1 1/4 - 11	1 1/4 - 11

ADAPTERS

9344 TEE F-BSP

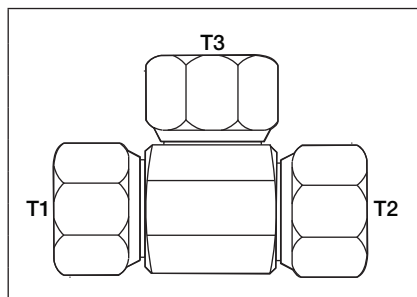

PART NUMBER	T1	T2	T3
9344-040404	1/4 - 19	1/4 - 19	1/4 - 19
9344-060606	3/8 - 19	3/8 - 19	3/8 - 19
9344-080808	1/2 - 14	1/2 - 14	1/2 - 14
9344-121212	3/4 - 14	3/4 - 14	3/4 - 14
9344-161616	1 - 11	1 - 11	1 - 11

9522P M-BSP PLUG

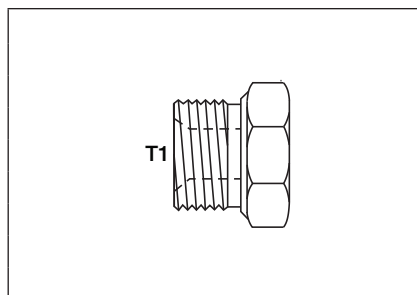

PART NUMBER	T1
9522P-02	1/8 - 28
9522P-04	1/4 - 19
9522P-06	3/8 - 19
9522P-08	1/2 - 14
9522P-10	5/8 - 14
9522P-12	3/4 - 14
9522P-16	1 - 11
9522P-20	1 1/4 - 11

9610 METRIC PLUG LIGHT

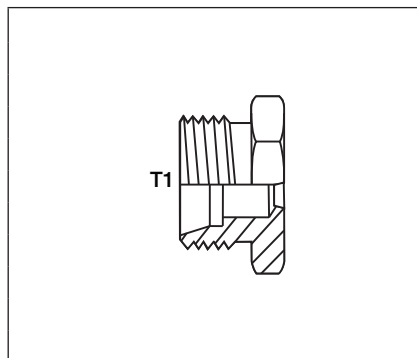

PART NUMBER	T1
D8004-L06	M12 x 1.5
D8004-L08	M14 x 1.5
D8004-L10	M16 x 1.5
D8004-L12	M18 x 1.5
D8004-L15	M22 x 1.5
D8004-L18	M26 x 1.5
D8004-L22	M30 x 2.0
D8004-L28	M36 x 2.0
D8004-L35	M42 x 2.0
D8004-L42	M52 x 2.0

9611 METRIC PLUG HEAVY

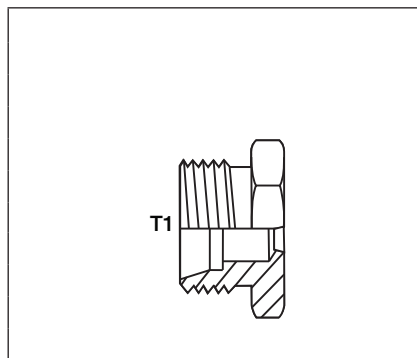

PART NUMBER	T1
D8004-S06	M14 x 1.5
D8004-S08	M16 x 1.5
D8004-S10	M18 x 1.5
D8004-S12	M20 x 1.5
D8004-S14	M22 x 1.5
D8004-S16	M24 x 1.5
D8004-S20	M30 x 2.0
D8004-S25	M36 x 2.0
D8004-S30	M42 x 2.0
D8004-S38	M52 x 2.0

ADAPTERS

9620 METRIC CAP LIGHT

	PART NUMBER	T1
	D8003-L06	M12 x 1.5
	D8003-L08	M14 x 1.5
	D8003-L10	M16 x 1.5
	D8003-L12	M18 x 1.5
	D8003-L15	M22 x 1.5
	D8003-L18	M26 x 1.5
	D8003-L22	M30 x 2.0
	D8003-L28	M36 x 2.0
	D8003-L35	M42 x 2.0
D8003-L42	M52 x 2.0	

9621 METRIC CAP HEAVY

	PART NUMBER	T1
	D8003-S06	M14 x 1.5
	D8003-S08	M16 x 1.5
	D8003-S10	M18 x 1.5
	D8003-S12	M20 x 1.5
	D8003-S14	M22 x 1.5
	D8003-S16	M24 x 1.5
	D8003-S20	M30 x 2.0
	D8003-S25	M36 x 2.0
	D8003-S30	M42 x 2.0
D8003-S38	M52 x 2.0	

9644C F-BSP CAP

	PART NUMBER	T1
	9644C-02	1/8 - 28
	9644C-04	1/4 - 19
	9644C-06	3/8 - 19
	9644C-08	1/2 - 14
	9644C-10	5/8 - 14
	9644C-12	3/4 - 14
	9644C-16	1 - 11
	9644C-20	1 1/4 - 11

9722LN M-BSP / M-BSP BULKHEAD

	PART NUMBER	T1	T2
	9722LN-0404	1/4 - 19	1/4 - 19
	9722LN-0606	3/8 - 19	3/8 - 19
	9722LN-0808	1/2 - 14	1/2 - 14
	9722LN-1212	3/4 - 14	3/4 - 14
	9722LN-1616	1 - 11	1 - 11
	9722LN-2020	1 1/4 - 11	1 1/4 - 11

ADAPTERS

9900

BSP BONDED SEAL

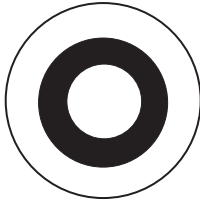

PART NUMBER	T1
9900-02	1/8
9900-04	1/4
9900-06	3/8
9900-08	1/2
9900-10	5/8
9900-12	3/4
9900-16	1
9900-20	1 1/4
9900-24	1 1/2
9900-32	2

ADAPTERS

FS0304 ORFS CAP

SAE # 520112

	PART NUMBER	T1
	FS0304-04	9/16 - 18
	FS0304-06	1 1/16 - 16
	FS0304-08	1 3/16 - 16
	FS0304-10	1 - 14
	FS0304-12	1 3/16 - 12
	FS0304-16	1 7/16 - 12
	FS0304-20	1 11/16 - 12
	FS0304-24	2 - 12

FS0306 ORFS BULKHEAD LOCKNUT

SAE # 520118

	PART NUMBER	T1
	FS0306-04	9/16 - 18
	FS0306-06	1 1/16 - 16
	FS0306-08	1 3/16 - 16
	FS0306-10	1 - 14
	FS0306-12	1 3/16 - 12
	FS0306-16	1 7/16 - 12
	FS0306-20	1 11/16 - 12
	FS0306-24	2 - 12

FS0318 ORFS TUBE NUT

SAE # 520110

	PART NUMBER	T1
	FS0318-04	9/16 - 18
	FS0318-06	1 1/16 - 16
	FS0318-08	1 3/16 - 16
	FS0318-10	1 - 14
	FS0318-12	1 3/16 - 12
	FS0318-16	1 7/16 - 12
	FS0318-20	1 11/16 - 12
	FS0318-24	2 - 12

FS0319 ORFS SLEEVE BRAZE STYLE

SAE # 520115

	PART NUMBER	TUBE O.D.	T1
	FS0319-04	1/4	0.502
	FS0319-06	3/8	0.620
	FS0319-08	1/2	0.745
	FS0319-10	5/8	0.923
	FS0319-12	3/4	1.097
	FS0319-16	1	1.347
	FS0319-20	1 1/4	1.597
	FS0319-24	1 1/2	1.910

ADAPTERS

FS0403 BORE / M-ORFS STRAIGHT BRAZE ON

	PART NUMBER	T1 (BORE)	T2
		FS0403-0404	0.256
FS0403-0604		0.381	9/16 - 18
FS0403-0606		0.381	1 1/16 - 16
FS0403-0608		0.381	1 3/16 - 16
FS0403-0806		0.506	1 1/16 - 16
FS0403-0808		0.506	1 3/16 - 16
FS0403-0812		0.506	1 3/16 - 12
FS0403-1008		0.631	1 3/16 - 16
FS0403-1010		0.631	1 - 14
FS0403-1012		0.631	1 3/16 - 12
FS0403-1210		0.757	1 - 14
FS0403-1212		0.757	1 3/16 - 12
FS0403-1216		0.757	1 7/16 - 12
FS0403-1612		1.007	1 3/16 - 12
FS0403-1616		1.007	1 7/16 - 12
FS0403-1620		1.007	1 11/16 - 12
FS0403-2020		1.258	1 11/16 - 12
FS0403-2420		1.508	1 11/16 - 12
FS0403-2424		1.508	2 - 12

FS2403 M-ORFS / M-ORFS STRAIGHT

SAE # 520101

	PART NUMBER	T1	T2
		FS2403-0404	9/16 - 18
FS2403-0604		1 1/16 - 16	9/16 - 18
FS2403-0606		1 1/16 - 16	1 1/16 - 16
FS2403-0806		1 3/16 - 16	1 1/16 - 16
FS2403-0808		1 3/16 - 16	1 3/16 - 16
FS2403-1008		1 - 14	1 3/16 - 16
FS2403-1010		1 - 14	1 - 14
FS2403-1208		1 3/16 - 12	1 3/16 - 12
FS2403-1210		1 3/16 - 12	1 - 14
FS2403-1212		1 3/16 - 12	1 3/16 - 12
FS2403-1612		1 7/16 - 12	1 3/16 - 12
FS2403-1616		1 7/16 - 12	1 7/16 - 12
FS2403-2016		1 11/16 - 12	1 7/16 - 12
FS2403-2020		1 11/16 - 12	1 11/16 - 12
FS2403-2420		2 - 12	1 11/16 - 12
FS2403-2424		2 - 12	2 - 12

ADAPTERS

FS2404 M-ORFS / M-NPT STRAIGHT

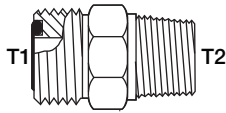

PART NUMBER	T1	T2
FS2404-0402	9/16 - 18	1/8 - 27
FS2404-0404	9/16 - 18	1/4 - 18
FS2404-0406	9/16 - 18	3/8 - 18
FS2404-0408	9/16 - 18	1/2 - 14
FS2404-0602	11/16 - 16	1/8 - 27
FS2404-0604	11/16 - 16	1/4 - 18
FS2404-0606	11/16 - 16	3/8 - 18
FS2404-0608	11/16 - 16	1/2 - 14
FS2404-0804	13/16 - 16	1/4 - 18
FS2404-0806	13/16 - 16	3/8 - 18
FS2404-0808	13/16 - 16	1/2 - 14
FS2404-0812	13/16 - 16	3/4 - 14
FS2404-0816	13/16 - 16	1 - 11 1/2
FS2404-1008	1 - 14	1/2 - 14
FS2404-1012	1 - 14	3/4 - 14
FS2404-1016	1 - 14	1 - 11 1/2
FS2404-1208	1 3/16 - 12	1/2 - 14
FS2404-1212	1 3/16 - 12	3/4 - 14
FS2404-1216	1 3/16 - 12	1 - 11 1/2
FS2404-1612	1 7/16 - 12	3/4 - 14
FS2404-1616	1 7/16 - 12	1 - 11 1/2
FS2404-1620	1 7/16 - 12	1 1/4 - 11 1/2
FS2404-2016	1 11/16 - 12	1 - 11 1/2
FS2404-2020	1 11/16 - 12	1 1/4 - 11 1/2
FS2404-2424	2 - 12	1 1/2 - 11 1/2

FS2406 F-ORFS / M-ORFS (REDUCER MAY BE SUPPLIED AS 2 PIECE ASSEMBLY)

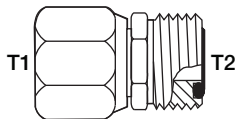

PART NUMBER	T1	T2
FS2406-0404	9/16 - 18	9/16 - 18
FS2406-0604	11/16 - 16	9/16 - 18
FS2406-0606	11/16 - 16	11/16 - 16
FS2406-0804	13/16 - 16	9/16 - 18
FS2406-0806	13/16 - 16	11/16 - 16
FS2406-0808	13/16 - 16	13/16 - 16
FS2406-1004	1 - 14	9/16 - 18
FS2406-1006	1 - 14	11/16 - 16
FS2406-1008	1 - 14	13/16 - 16
FS2406-1204	1 3/16 - 12	9/16 - 18
FS2406-1206	1 3/16 - 12	11/16 - 16
FS2406-1208	1 3/16 - 12	13/16 - 16
FS2406-1210	1 3/16 - 12	1 - 14
FS2406-1216	1 3/16 - 12	1 7/16 - 12
FS2406-1608	1 7/16 - 12	13/16 - 16
FS2406-1610	1 7/16 - 12	1 - 14
FS2406-1612	1 7/16 - 12	1 3/16 - 12
FS2406-2012	1 11/16 - 12	1 3/16 - 12
FS2406-2016	1 11/16 - 12	1 7/16 - 12
FS2406-2024	1 11/16 - 12	2 - 12
FS2406-2416	1	2 - 12
FS2406-2420	2 - 12	1 11/16 - 12

ADAPTERS

FS2408

ORFS HEX PLUG

SAE #520109

	PART NUMBER	T1
	FS2408-04	9/16 - 18
	FS2408-06	11/16 - 16
	FS2408-08	13/16 - 16
	FS2408-10	1 - 14
	FS2408-12	1 3/16 - 12
	FS2408-16	1 7/16 - 12
	FS2408-20	1 11/16 - 12
	FS2408-24	2 - 12

FS2500

90° M-ORFS / M-ORFS

SAE # 520201

	PART NUMBER	T1	T2
	FS2500-0404	9/16 - 18	9/16 - 18
	FS2500-0606	11/16 - 16	11/16 - 16
	FS2500-0808	13/16 - 16	13/16 - 16
	FS2500-1010	1 - 14	1 - 14
	FS2500-1208	1 3/16 - 12	1 3/16 - 16
	FS2500-1212	1 3/16 - 12	1 3/16 - 12
	FS2500-1616	1 7/16 - 12	1 7/16 - 12
	FS2500-2020	1 11/16 - 12	1 11/16 - 12
	FS2500-2424	2 - 12	2 - 12

FS2501

90° M-ORFS / M-NPT

	PART NUMBER	T1	T2
	FS2501-0402	9/16 - 18	1/8 - 27
	FS2501-0404	9/16 - 18	1/4 - 18
	FS2501-0406	9/16 - 18	3/8 - 18
	FS2501-0604	1 1/16 - 16	1/4 - 18
	FS2501-0606	1 1/16 - 16	3/8 - 18
	FS2501-0608	1 1/16 - 16	1/2 - 14
	FS2501-0804	1 3/16 - 16	1/4 - 18
	FS2501-0806	1 3/16 - 16	3/8 - 18
	FS2501-0808	1 3/16 - 16	1/2 - 14
	FS2501-0812	1 3/16 - 16	3/4 - 14
	FS2501-1008	1 - 14	1/2 - 14
	FS2501-1012	1 - 14	3/4 - 14
	FS2501-1208	1 3/16 - 12	1/2 - 14
	FS2501-1212	1 3/16 - 12	3/4 - 14
	FS2501-1216	1 3/16 - 12	1 - 11 1/2
	FS2501-1612	1 7/16 - 12	3/4 - 14
	FS2501-1616	1 7/16 - 12	1 - 11 1/2
	FS2501-2016	1 11/16 - 12	1 - 11 1/2
	FS2501-2020	1 11/16 - 12	1 1/4 - 11 1/2
FS2501-2424	2 - 12	1 1/2 - 11 1/2	

ADAPTERS

FS2503 45° M-ORFS / M-NPT

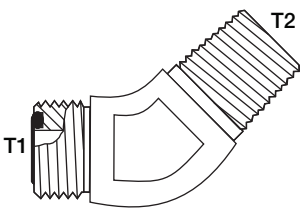
	PART NUMBER	T1	T2
	FS2503-0402	9/16 - 18	1/8 - 27
FS2503-0404	9/16 - 18	1/4 - 18	
FS2503-0604	1 1/16 - 16	1/4 - 18	
FS2503-0606	1 1/16 - 16	3/8 - 18	
FS2503-0608	1 1/16 - 16	1/2 - 14	
FS2503-0806	1 3/16 - 16	3/8 - 18	
FS2503-0808	1 3/16 - 16	1/2 - 14	
FS2503-0812	1 3/16 - 16	3/4 - 14	
FS2503-1008	1 - 14	1/2 - 14	
FS2503-1208	1 3/16 - 12	1/2 - 14	
FS2503-1212	1 3/16 - 12	3/4 - 14	
FS2503-1616	1 7/16 - 12	1 - 11 1/2	
FS2503-2020	1 11/16 - 12	1 1/4 - 11 1/2	

FS2601 BRANCH TEE M-ORFS / M-ORFS / M-NPT

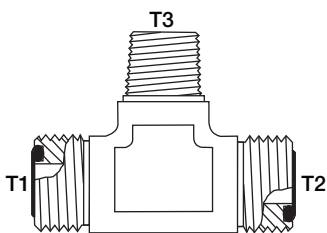
	PART NUMBER	T1	T2	T3
	FS2601-040404	9/16 - 18	9/16 - 18	1/4 - 18
FS2601-060604	1 1/16 - 16	1 1/16 - 16	1/4 - 18	
FS2601-060606	1 1/16 - 16	1 1/16 - 16	3/8 - 18	
FS2601-080808	1 3/16 - 16	1 3/16 - 16	1/2 - 14	
FS2601-121212	1 3/16 - 12	1 3/16 - 12	3/4 - 14	
FS2601-161616	1 7/16 - 12	1 7/16 - 12	1 - 11 1/2	

FS2603 TEE M-ORFS

SAE # 520401

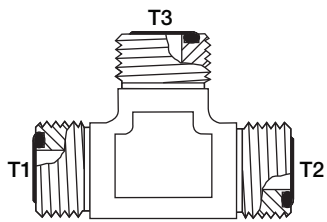
	PART NUMBER	T1	T2	T3
	FS2603-040404	9/16 - 18	9/16 - 18	9/16 - 18
FS2603-060606	1 1/16 - 16	1 1/16 - 16	1 1/16 - 16	
FS2603-060608	1 1/16 - 16	1 1/16 - 16	1 3/16 - 16	
FS2603-080808	1 3/16 - 16	1 3/16 - 16	1 3/16 - 16	
FS2603-101010	1 - 14	1 - 14	1 - 14	
FS2603-121212	1 3/16 - 12	1 3/16 - 12	1 3/16 - 12	
FS2603-121216	1 3/16 - 12	1 3/16 - 12	1 7/16 - 12	
FS2603-161616	1 7/16 - 12	1 7/16 - 12	1 7/16 - 12	
FS2603-202020	1 11/16 - 12	1 11/16 - 12	1 11/16 - 12	
FS2603-242424	2 - 12	2 - 12	2 - 12	

ADAPTERS

FS2650 CROSS M-ORFS

	PART NUMBER	T1	T2	T3	T4
	FS2650-04040404	9/16 - 18	9/16 - 18	9/16 - 18	9/16 - 18
	FS2650-06060606	1 1/16 - 16	1 1/16 - 16	1 1/16 - 16	1 1/16 - 16
	FS2650-08080808	1 3/16 - 16	1 3/16 - 16	1 3/16 - 16	1 3/16 - 16
	FS2650-10101010	1 - 14	1 - 14	1 - 14	1 - 14
	FS2650-12121212	1 3/16 - 12	1 3/16 - 12	1 3/16 - 12	1 3/16 - 12
	FS2650-16161616	1 7/16 - 12	1 7/16 - 12	1 7/16 - 12	1 7/16 - 12
	FS2650-20202020	1 11/16 - 12	1 11/16 - 12	1 11/16 - 12	1 11/16 - 12
	FS2650-24242424	2 - 12	2 - 12	2 - 12	2 - 12

FS2700LN M-ORFS / M-ORFS BULKHEAD INCLUDES NUT SAE # 520601

	PART NUMBER	T1	T2
	FS2700LN-0404	9/16 - 18	9/16 - 18
	FS2700LN-0606	1 1/16 - 16	1 1/16 - 16
	FS2700LN-0608	1 1/16 - 16	1 3/16 - 16
	FS2700LN-0808	1 3/16 - 16	1 3/16 - 16
	FS2700LN-1010	1 - 14	1 - 14
	FS2700LN-1212	1 3/16 - 12	1 3/16 - 12
	FS2700LN-1616	1 7/16 - 12	1 7/16 - 12
	FS2700LN-2020	1 11/16 - 12	1 11/16 - 12
FS2700LN-2424	2 - 12	2 - 12	

FS2701LN 90° M-ORFS / M-ORFS BULKHEAD INCLUDES NUT SAE # 520701

	PART NUMBER	T1	T2
	FS2701LN-0404	9/16 - 18	9/16 - 18
	FS2701LN-0606	1 1/16 - 16	1 1/16 - 16
	FS2701LN-0608	1 1/16 - 16	1 3/16 - 16
	FS2701LN-0808	1 3/16 - 16	1 3/16 - 16
	FS2701LN-0810	1 3/16 - 16	1 - 14
	FS2701LN-1010	1 - 14	1 - 14
	FS2701LN-1212	1 3/16 - 12	1 3/16 - 12
	FS2701LN-1616	1 7/16 - 12	1 7/16 - 12
FS2701LN-2020	1 11/16 - 12	1 11/16 - 12	
FS2701LN-2424	2 - 12	2 - 12	

ADAPTERS

FS2702LN 45° M-ORFS / M-ORFS BULKHEAD

SAE # 520801

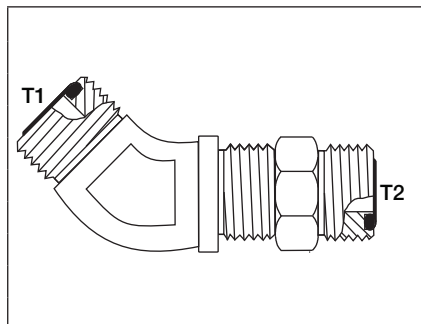

PART NUMBER	T1	T2
FS2702LN-0404	9/16 - 18	9/16 - 18
FS2702LN-0606	1 1/16 - 16	1 1/16 - 16
FS2702LN-0808	1 3/16 - 16	1 3/16 - 16
FS2702LN-1008	1 3/16 - 16	1 - 14
FS2702LN-1010	1 - 14	1 - 14
FS2702LN-1212	1 3/16 - 12	1 3/16 - 12
FS2702LN-1616	1 7/16 - 12	1 7/16 - 12
FS2702LN-2020	1 1 1/16 - 12	1 1 1/16 - 12
FS2702LN-2424	2 - 12	2 - 12

FS2703LN BRANCH TEE / M-ORFS / M-ORFS / ORFS BULKHEAD INCLUDES NUT

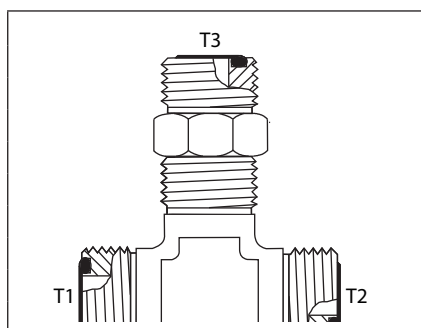

PART NUMBER	T1	T2	T3
FS2703LN-040404	9/16 - 18	9/16 - 18	9/16 - 18
FS2703LN-060606	1 1/16 - 16	1 1/16 - 16	1 1/16 - 16
FS2703LN-080808	1 3/16 - 16	1 3/16 - 16	1 3/16 - 16
FS2703LN-121212	1 3/16 - 12	1 3/16 - 12	1 3/16 - 12
FS2703LN-161616	1 7/16 - 12	1 7/16 - 12	1 7/16 - 12

FS2704LN RUN TEE M-ORFS / ORFS BULKHEAD / M-ORFS INCLUDES NUT SAE # 520201

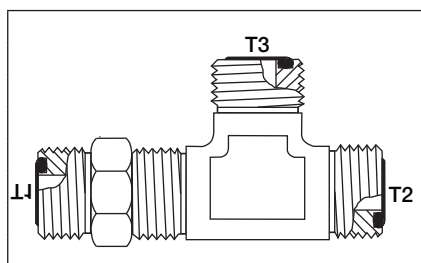

PART NUMBER	T1	T2	T3
FS2704LN-040404	9/16 - 18	9/16 - 18	9/16 - 18
FS2704LN-060606	1 1/16 - 16	1 1/16 - 16	1 1/16 - 16
FS2704LN-080808	1 3/16 - 16	1 3/16 - 16	1 3/16 - 16
FS2704LN-101010	1 - 14	1 - 14	1 - 14
FS2704LN-121212	1 3/16 - 12	1 3/16 - 12	1 3/16 - 12
FS2704LN-161616	1 7/16 - 12	1 7/16 - 12	1 7/16 - 12
FS2704LN-202020	1 1 1/16 - 12	1 1 1/16 - 12	1 1 1/16 - 12

ADAPTERS

FS6400

M-ORFS / M-ORB

SAE # 520122

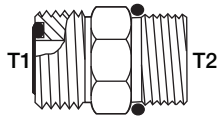

PART NUMBER	T1	T2
FS6400-0404	9/16 - 18	7/16 - 20
FS6400-0405	9/16 - 18	1/2 - 20
FS6400-0406	9/16 - 18	9/16 - 18
FS6400-0408	9/16 - 18	3/4 - 16
FS6400-0604	1 1/16 - 16	7/16 - 20
FS6400-0605	1 1/16 - 16	1/2 - 20
FS6400-0606	1 1/16 - 16	9/16 - 18
FS6400-0608	1 1/16 - 16	3/4 - 16
FS6400-0610	1 1/16 - 16	7/8 - 14
FS6400-0612	1 1/16 - 16	1 1/16 - 12
FS6400-0804	1 3/16 - 16	7/16 - 20
FS6400-0806	1 3/16 - 16	9/16 - 18
FS6400-0808	1 3/16 - 16	3/4 - 16
FS6400-0810	1 3/16 - 16	7/8 - 14
FS6400-0812	1 3/16 - 16	1 1/16 - 12
FS6400-0816	1 3/16 - 16	1 5/16 - 12
FS6400-1006	1 - 14	9/16 - 18
FS6400-1008	1 - 14	3/4 - 16
FS6400-1010	1 - 14	7/8 - 14
FS6400-1012	1 - 14	1 1/16 - 12
FS6400-1206	1 3/16 - 12	9/16 - 18
FS6400-1208	1 3/16 - 12	3/4 - 16
FS6400-1210	1 3/16 - 12	7/8 - 14
FS6400-1212	1 3/16 - 12	1 1/16 - 12
FS6400-1216	1 3/16 - 12	1 5/16 - 12
FS6400-1608	1 7/16 - 12	3/4 - 16
FS6400-1610	1 7/16 - 12	7/8 - 14
FS6400-1612	1 7/16 - 12	1 1/16 - 12
FS6400-1616	1 7/16 - 12	1 5/16 - 12
FS6400-1620	1 7/16 - 12	1 5/8 - 12
FS6400-2016	1 1 1/16 - 12	1 5/16 - 12
FS6400-2020	1 1 1/16 - 12	1 5/8 - 12
FS6400-2024	1 1 1/16 - 12	1 7/8 - 12
FS6400-2420	2 - 12	1 5/8 - 12
FS6400-2424	2 - 12	1 7/8 - 12

ADAPTERS O-RING FACE SEAL

ADAPTERS

FS6402 M-ORFS / F-JIC STRAIGHT

	PART NUMBER	T1	T2
	FS6402-0404	9/16 - 18	7/16 - 20
	FS6402-0606	1 1/16 - 16	9/16 - 18
	FS6402-0808	1 3/16 - 16	3/4 - 16
	FS6402-1010	1 - 14	7/8 - 14
	FS6402-1212	1 3/16 - 12	1 1/16 - 12
FS6402-1616	1 7/16 - 12	1 5/16 - 12	

FS6403 M-ORFS / M-JIC

	PART NUMBER	T1	T2
	FS6403-0404	9/16 - 18	7/16 - 20
	FS6403-0606	1 1/16 - 16	9/16 - 18
	FS6403-0808	1 3/16 - 16	3/4 - 16
	FS6403-1010	1 - 14	7/8 - 14
	FS6403-1212	1 3/16 - 12	1 1/16 - 12
FS6403-1616	1 7/16 - 12	1 5/16 - 12	

FS6500 90° M-ORFS / F-ORFS

SAE # 520221

	PART NUMBER	T1	T2
	FS6500-0404	9/16 - 18	9/16 - 18
	FS6500-0406	9/16 - 18	1 1/16 - 16
	FS6500-0606	1 1/16 - 16	1 1/16 - 16
	FS6500-0806	1 3/16 - 16	1 1/16 - 16
	FS6500-0808	1 3/16 - 16	1 3/16 - 16
	FS6500-1010	1 - 14	1 - 14
	FS6500-1212	1 3/16 - 12	1 3/16 - 12
	FS6500-1616	1 7/16 - 12	1 7/16 - 12
	FS6500-2020	1 11/16 - 12	1 11/16 - 12
FS6500-2424	2 - 12	2 - 12	

FS6502 45° M-ORFS / F-ORFS

	PART NUMBER	T1	T2
	FS6502-0404	9/16 - 18	9/16 - 18
	FS6502-0606	1 1/16 - 16	1 1/16 - 16
	FS6502-0808	1 3/16 - 16	1 3/16 - 16
	FS6502-1010	1 - 14	1 - 14
	FS6502-1212	1 3/16 - 12	1 3/16 - 12
FS6502-1616	1 7/16 - 12	1 7/16 - 12	

ADAPTERS

FS6504 F-ORFS / M-JIC STRAIGHT

	PART NUMBER	T1	T2
	FS6504-0404	9/16 - 18	7/16 - 20
	FS6504-0606	1 1/16 - 16	9/16 - 18
	FS6504-0808	1 3/16 - 16	3/4 - 16
	FS6504-1010	1 - 14	7/8 - 14
	FS6504-1212	1 3/16 - 12	1 1/16 - 12
	FS6504-1616	1 7/16 - 12	1 5/16 - 12
	FS6504-2020	1 11/16 - 12	1 5/8 - 12

FS6600 BRANCH TEE M-ORFS / M-ORFS / F-ORFS

SAE # 520433

	PART NUMBER	T1	T2	T3
	FS6600-040404	9/16 - 18	9/16 - 18	9/16 - 18
	FS6600-060606	1 1/16 - 16	1 1/16 - 16	1 1/16 - 16
	FS6600-080808	1 3/16 - 16	1 3/16 - 16	1 3/16 - 16
	FS6600-101010	1 - 14	1 - 14	1 - 14
	FS6600-121212	1 3/16 - 12	1 3/16 - 12	1 3/16 - 12
	FS6600-161616	1 7/16 - 12	1 7/16 - 12	1 7/16 - 12
	FS6600-202020	1 11/16 - 12	1 11/16 - 12	1 11/16 - 12
	FS6600-242424	2 - 12	2 - 12	2 - 12

FS6602 RUN TEE M-ORFS / F-ORFS / M-ORFS

SAE # 520432

	PART NUMBER	T1	T2	T3
	FS6602-040404	9/16 - 18	9/16 - 18	9/16 - 18
	FS6602-060606	1 1/16 - 16	1 1/16 - 16	1 1/16 - 16
	FS6602-080808	1 3/16 - 16	1 3/16 - 16	1 3/16 - 16
	FS6602-101010	1 - 14	1 - 14	1 - 14
	FS6602-121212	1 3/16 - 12	1 3/16 - 12	1 3/16 - 12
	FS6602-161616	1 7/16 - 12	1 7/16 - 12	1 7/16 - 12
	FS6602-202020	1 11/16 - 12	1 11/16 - 12	1 11/16 - 12
	FS6602-242424	2 - 12	2 - 12	2 - 12

ADAPTERS

FS6801

90° M-ORFS / M-ORB

SAE # 520220

	PART NUMBER		
	T1	T2	
	FS6801-0404	9/16 - 18	7/16 - 20
	FS6801-0405	9/16 - 18	1/2 - 20
	FS6801-0406	9/16 - 18	9/16 - 18
	FS6801-0408	9/16 - 18	3/4 - 16
	FS6801-0604	1 1/16 - 16	7/16 - 20
	FS6801-0605	1 1/16 - 16	1/2 - 20
	FS6801-0606	1 1/16 - 16	9/16 - 18
	FS6801-0608	1 1/16 - 16	3/4 - 16
	FS6801-0610	1 1/16 - 16	7/8 - 14
	FS6801-0612	1 1/16 - 16	1 1/16 - 12
	FS6801-0804	1 3/16 - 16	7/16 - 20
	FS6801-0806	1 3/16 - 16	9/16 - 18
	FS6801-0808	1 3/16 - 16	3/4 - 16
	FS6801-0810	1 3/16 - 16	7/8 - 14
	FS6801-0812	1 3/16 - 16	1 1/16 - 12
	FS6801-1008	1 - 14	3/4 - 16
	FS6801-1010	1 - 14	7/8 - 14
	FS6801-1012	1 - 14	1 1/16 - 12
	FS6801-1208	1 3/16 - 12	3/4 - 16
	FS6801-1210	1 3/16 - 12	7/8 - 14
	FS6801-1212	1 3/16 - 12	1 1/16 - 12
	FS6801-1216	1 3/16 - 12	1 5/16 - 12
	FS6801-1612	1 7/16 - 12	1 1/16 - 12
	FS6801-1616	1 7/16 - 12	1 5/16 - 12
	FS6801-1620	1 7/16 - 12	1 5/8 - 12
	FS6801-2012	1 11/16 - 12	1 1/16 - 12
	FS6801-2016	1 11/16 - 12	1 5/16 - 12
	FS6801-2020	1 11/16 - 12	1 5/8 - 12
	FS6801-2024	1 11/16 - 12	1 7/8 - 12
	FS6801-2420	2 - 12	1 5/8 - 12
	FS6801-2424	2 - 12	1 7/8 - 12

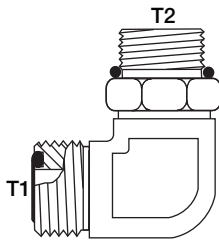

FS6801L

90° M-ORFS / M-ORB LONG

	PART NUMBER		
	T1	T2	
	FS6801L-0404	9/16 - 18	7/16 - 20
	FS6801L-0606	1 1/16 - 16	9/16 - 18
	FS6801L-0808	1 3/16 - 16	3/4 - 16
	FS6801L-1010	1 - 14	7/8 - 14
	FS6801L-1212	1 3/16 - 12	1 1/16 - 12
	FS6801L-1616	1 7/16 - 12	1 5/16 - 12

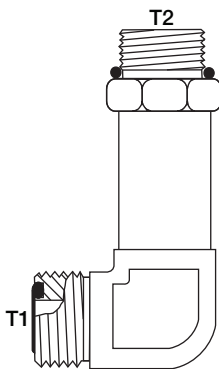

ADAPTERS

FS6802

45° M-ORFS / M-ORB

SAE # 520320

	PART NUMBER	T1	T2
		FS6802-0404	1 ¹ / ₁₆ - 16
FS6802-0406		1 ¹ / ₁₆ - 16	9 ¹ / ₁₆ - 18
FS6802-0604		1 ¹ / ₁₆ - 16	7 ¹ / ₁₆ - 20
FS6802-0606		1 ¹ / ₁₆ - 16	9 ¹ / ₁₆ - 18
FS6802-0608		1 ¹ / ₁₆ - 16	3 ⁴ / ₈ - 16
FS6802-0610		1 ¹ / ₁₆ - 16	7 ⁸ / ₈ - 14
FS6802-0806		1 ³ / ₁₆ - 16	9 ¹ / ₁₆ - 18
FS6802-0808		1 ³ / ₁₆ - 16	3 ⁴ / ₈ - 16
FS6802-0810		1 ³ / ₁₆ - 16	7 ⁸ / ₈ - 14
FS6802-0812		1 ³ / ₁₆ - 16	1 ¹ / ₁₆ - 12
FS6802-1008		1 - 14	3 ⁴ / ₈ - 16
FS6802-1010		1 - 14	7 ⁸ / ₈ - 14
FS6802-1012		1 - 14	1 ¹ / ₁₆ - 12
FS6802-1208		1 ³ / ₁₆ - 12	3 ⁴ / ₈ - 16
FS6802-1210		1 ³ / ₁₆ - 12	7 ⁸ / ₈ - 14
FS6802-1212		1 ³ / ₁₆ - 12	1 ¹ / ₁₆ - 12
FS6802-1216		1 ³ / ₁₆ - 12	1 ⁵ / ₁₆ - 12
FS6802-1612		1 ⁷ / ₁₆ - 12	1 ¹ / ₁₆ - 12
FS6802-1616		1 ⁷ / ₁₆ - 12	1 ⁵ / ₁₆ - 12
FS6802-1620		1 ⁷ / ₁₆ - 12	1 ⁵ / ₈ - 12
FS6802-2016	1 ¹¹ / ₁₆ - 12	1 ⁵ / ₁₆ - 12	
FS6802-2020	1 ¹¹ / ₁₆ - 12	1 ⁵ / ₈ - 12	
FS6802-2424	2 - 12	1 ⁷ / ₈ - 12	

FS6803

BRANCH TEE M-ORFS / M-ORFS / M-ORB

SAE # 520429

	PART NUMBER	T1	T2	T3
		FS6803-040404	9 ¹ / ₁₆ - 18	9 ¹ / ₁₆ - 18
FS6803-060606		1 ¹ / ₁₆ - 16	1 ¹ / ₁₆ - 16	9 ¹ / ₁₆ - 18
FS6803-060608		1 ¹ / ₁₆ - 16	1 ¹ / ₁₆ - 16	3 ⁴ / ₈ - 16
FS6803-080808		1 ³ / ₁₆ - 16	1 ³ / ₁₆ - 16	3 ⁴ / ₈ - 16
FS6803-101010		1 - 14	1 - 14	7 ⁸ / ₈ - 14
FS6803-121212		1 ³ / ₁₆ - 12	1 ³ / ₁₆ - 12	1 ¹ / ₁₆ - 12
FS6803-161616		1 ⁷ / ₁₆ - 12	1 ⁷ / ₁₆ - 12	1 ⁵ / ₁₆ - 12
FS6803-202020		1 ¹¹ / ₁₆ - 12	1 ¹¹ / ₁₆ - 12	1 ⁵ / ₈ - 12
FS6803-242424		2 - 12	2 - 12	1 ⁷ / ₈ - 12

ADAPTERS

FS6804

RUN TEE M-ORFS / M-ORB / M-ORFS

SAE # 520429

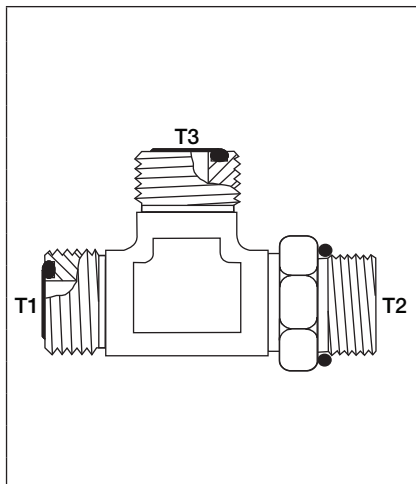

PART NUMBER	T1	T2	T3
FS6804-040404	9/16 - 18	7/16 - 20	9/16 - 18
FS6804-060406	1 1/16 - 16	7/16 - 20	1 1/16 - 16
FS6804-060606	1 1/16 - 16	9/16 - 18	1 1/16 - 16
FS6804-080608	1 3/16 - 16	9/16 - 18	1 3/16 - 16
FS6804-080808	1 3/16 - 16	3/4 - 16	1 3/16 - 16
FS6804-081008	1 3/16 - 16	7/8 - 14	1 3/16 - 16
FS6804-081208	1 3/16 - 16	1 1/16 - 12	1 3/16 - 16
FS6804-101010	1 - 14	7/8 - 14	1 - 14
FS6804-101210	1 - 14	1 1/16 - 12	1 - 14
FS6804-121212	1 3/16 - 12	1 1/16 - 12	1 3/16 - 12
FS6804-121216	1 3/16 - 12	1 1/16 - 12	1 7/16 - 12
FS6804-161616	1 7/16 - 12	1 5/16 - 12	1 7/16 - 12
FS6804-202020	1 11/16 - 12	1 5/8 - 12	1 11/16 - 12
FS6804-242424	2 - 12	1 7/8 - 12	2 - 12

FS6809

90° F-ORFS / M-ORB

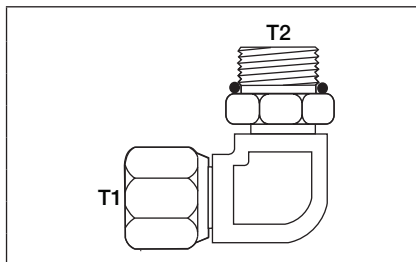

PART NUMBER	T1	T2
FS6809-0404	9/16 - 18	7/16 - 20
FS6809-0606	1 1/16 - 16	9/16 - 18
FS6809-0808	1 3/16 - 16	3/4 - 16
FS6809-1010	1 - 14	7/8 - 14
FS6809-1212	1 3/16 - 12	1 1/16 - 12
FS6809-1616	1 7/16 - 12	1 5/16 - 12
FS6809-2020	1 11/16 - 12	1 5/8 - 12

FS7205

90° M-ORFS / M-METRIC PORT

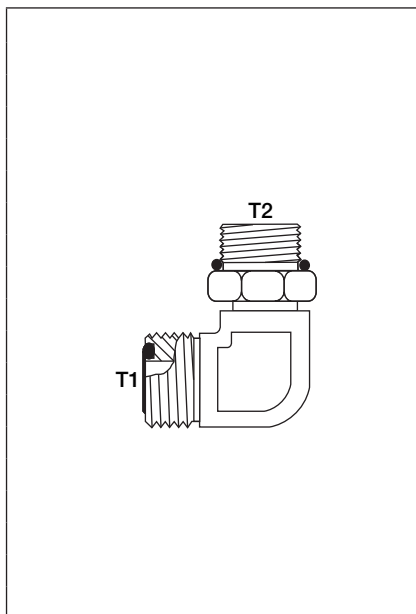

PART NUMBER	T1	T2
FS7205-0412	9/16 - 18	M12 x 1.5
FS7205-0414	9/16 - 18	M14 x 1.5
FS7205-0610	1 1/16 - 16	M10 x 1.0
FS7205-0612	1 1/16 - 16	M12 x 1.5
FS7205-0614	1 1/16 - 16	M14 x 1.5
FS7205-0616	1 1/16 - 16	M16 x 1.5
FS7205-0618	1 1/16 - 16	M18 x 1.5
FS7205-0814	1 3/16 - 16	M14 x 1.5
FS7205-0816	1 3/16 - 16	M16 x 1.5
FS7205-0818	1 3/16 - 16	M18 x 1.5
FS7205-1018	1 - 14	M18 x 1.5
FS7205-1022	1 - 14	M22 x 1.5
FS7205-1027	1 - 14	M27 x 2.0
FS7205-1222	1 3/16 - 12	M22 x 1.5
FS7205-1227	1 3/16 - 12	M27 x 2.0
FS7205-1633	1 7/16 - 12	M33 x 2.0
FS7205-2033	1 11/16 - 12	M33 x 2.0
FS7205-2042	1 11/16 - 12	M42 x 2.0

ADAPTERS

FS7210 M-ORFS / M-ORFS / M-METRIC PORT

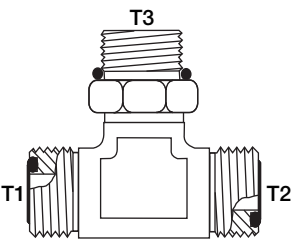
	PART NUMBER	T1	T2	T3
	FS7210-040412	9/16 - 18	9/16 - 18	M12 x 1.5
FS7210-040414	9/16 - 18	9/16 - 18	M14 x 1.5	
FS7210-060614	1 1/16 - 16	1 1/16 - 16	M14 x 1.5	
FS7210-060616	1 1/16 - 16	1 1/16 - 16	M16 x 1.5	
FS7210-080814	1 3/16 - 16	1 3/16 - 16	M14 x 1.5	
FS7210-080818	1 3/16 - 16	1 3/16 - 16	M18 x 1.5	
FS7210-080822	1 3/16 - 16	1 3/16 - 16	M22 x 1.5	
FS7210-101022	1-14	1-14	M22 x 1.5	
FS7210-121227	1 3/16 - 12	1 3/16 - 12	M27 x 2.0	
FS7210-161633	1 7/16 - 12	1 7/16 - 12	M33 x 2.0	
FS7210-202042	1 11/16 - 12	1 11/16 - 12	M42 x 2.0	
FS7210-242448	2 - 12	2 - 12	M48 x 2.0	

FS7215 M-ORFS / M-METRIC PORT / M-ORFS TEE

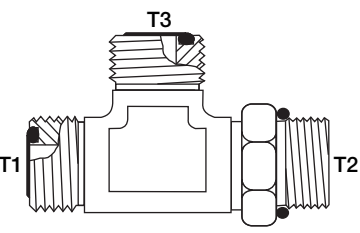
	PART NUMBER	T1	T2	T3
	FS7215-041204	9/16 - 18	M12 x 1.5	9/16 - 18
FS7215-041404	9/16 - 18	M14 x 1.5	9/16 - 18	
FS7215-061406	1 1/16 - 16	M14 x 1.5	1 1/16 - 16	
FS7215-061606	1 1/16 - 16	M16 x 1.5	1 1/16 - 16	
FS7215-081408	1 3/16 - 16	M14 x 1.5	1 3/16 - 16	
FS7215-081808	1 3/16 - 16	M18 x 1.5	1 3/16 - 16	
FS7215-082208	1 3/16 - 16	M22 x 1.5	1 3/16 - 16	
FS7215-101810	1-14	M18 x 1.5	1-14	
FS7215-102210	1-14	M22 x 1.5	1-14	
FS7215-122712	1 3/16 - 12	M27 x 2.0	1 3/16 - 12	
FS7215-163316	1 7/16 - 12	M22 x 2.0	1 7/16 - 12	
FS7215-244824	2 - 12	M48 x 2.0	2 - 12	

FS7300 M-ORFS / M-METRIC PORT 45° ELBOW

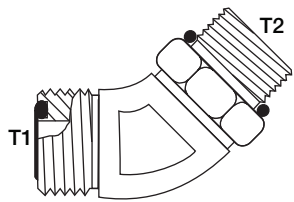
	PART NUMBER	T1	T2
	FS7300-0414	9/16 - 18	M14 x 1.5
FS7300-0616	1 1/16 - 16	M16 x 1.5	
FS7300-0814	1 3/16 - 16	M14 x 1.5	
FS7300-0818	1 3/16 - 16	M18 x 1.5	
FS7300-1022	1-14	M22 x 1.5	
FS7300-1227	1 3/16 - 12	M27 x 2.0	
FS7300-1633	1 7/16 - 12	M33 x 2.0	
FS7300-2042	1 11/16 - 12	M42 x 2.0	
FS7300-2448	2 - 12	M48 x 2.0	

ADAPTERS

FS7640

M-ORFS / M-METRIC PORT STRAIGHT

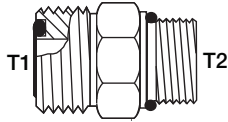

PART NUMBER	T1	T2
FS7640-0410	9/16 - 18	M10 x 1
FS7640-0412	9/16 - 18	M12 x 1.5
FS7640-0414	9/16 - 18	M14 x 1.5
FS7640-0614	1 1/16 - 16	M14 x 1.5
FS7640-0616	1 1/16 - 16	M16 x 1.5
FS7640-0618	1 1/16 - 16	M18 x 1.5
FS7640-0622	1 1/16 - 16	M22 x 1.5
FS7640-0814	1 3/16 - 16	M14 x 1.5
FS7640-0816	1 3/16 - 16	M16 x 1.5
FS7640-0818	1 3/16 - 16	M18 x 1.5
FS7640-0822	1 3/16 - 16	M22 x 1.5
FS7640-0827	1 3/16 - 16	M27 x 2.0
FS7640-0833	1 3/16 - 16	M33 x 2.0
FS7640-1018	1 - 14	M18 x 1.5
FS7640-1022	1 - 14	M22 x 1.5
FS7640-1027	1 - 14	M27 x 2.0
FS7640-1033	1 - 14	M33 x 2.0
FS7640-1222	1 3/16 - 12	M22 x 1.5
FS7640-1227	1 3/16 - 12	M27 x 2.0
FS7640-1233	1 3/16 - 12	M33 x 2.0
FS7640-1633	1 7/16 - 12	M33 x 2.0
FS7640-2038	1 11/16 - 12	M38 x 2.0
FS7640-2042	1 11/16 - 12	M42 x 2.0

ADAPTERS

C0304 FLARELESS CAP

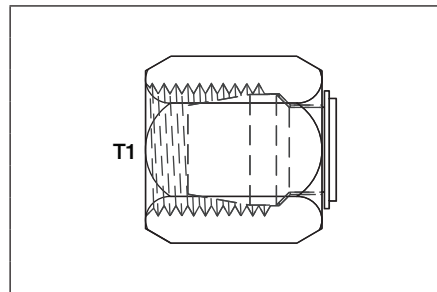

Part Number	T1
C0304-02	1/8
C0304-04	1/4
C0304-06	3/8
C0304-08	1/2
C0304-10	5/8
C0304-12	3/4
C0304-16	1
C0304-20	1 1/4

C0306 FLARELESS BULKHEAD LOCKNUT

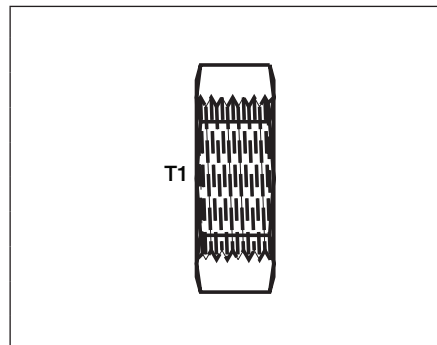

Part Number	T1
C0306-04	1/4
C0306-06	3/8
C0306-08	1/2
C0306-10	5/8
C0306-12	3/4
C0306-16	1
C0306-20	1 1/4
C0306-24	1 1/2
C0306-32	2

C0318 FLARELESS NUT

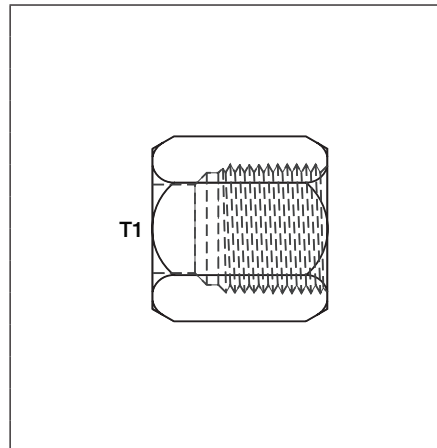

Part Number	T1
C0318-02	1/8
C0318-03	3/16
C0318-04	1/4
C0318-05	5/16
C0318-06	3/8
C0318-08	1/2
C0318-10	5/8
C0318-12	3/4
C0318-14	7/8
C0318-16	1
C0318-20	1 1/4
C0318-24	1 1/2
C0318-32	2

ADAPTERS

C0319 FLARELESS COMPRESSION SLEEVE

	Part Number	T1
	C0319-02	1/8
	C0319-03	3/16
	C0319-04	1/4
	C0319-05	5/16
	C0319-06	3/8
	C0319-08	1/2
	C0319-10	5/8
	C0319-12	3/4
	C0319-14	7/8
	C0319-16	1
	C0319-20	1 1/4
	C0319-24	1 1/2
	C0319-32	2

C2403 FLARELESS / FLARELESS

	Part Number	T1	T2
	C2403-0202	1/8	1/8
	C2403-0303	3/16	3/16
	C2403-0404	1/4	1/4
	C2403-0505	5/16	5/16
	C2403-0604	3/8	1/4
	C2403-0606	3/8	3/8
	C2403-0808	1/2	1/2
	C2403-1010	5/8	5/8
	C2403-1212	3/4	3/4
	C2403-1414	7/8	7/8
	C2403-1616	1	1
	C2403-2020	1 1/4	1 1/4
	C2403-2424	1 1/2	1 1/2
	C2403-3232	2	2

C2403LH FLARELESS / FLARELESS - LARGE HEX

	Part Number	T1	T2
	C2403LH-0404	1/4	1/4
	C2403LH-0606	3/8	3/8
	C2403LH-0808	1/2	1/2
	C2403LH-1212	3/4	3/4
	C2403LH-1616	1	1

ADAPTERS

C2404 FLARELESS / M-NPT

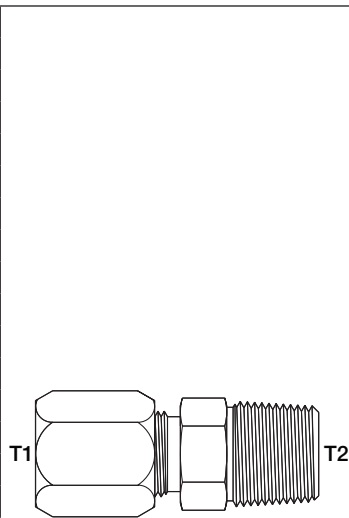

Part Number	T1	T2
C2404-0202	1/8	1/8 - 27
C2404-0204	1/8	1/4 - 18
C2404-0302	3/16	1/8 - 27
C2404-0402	1/4	1/8 - 27
C2404-0404	1/4	1/4 - 18
C2404-0406	1/4	3/8 - 18
C2404-0408	1/4	1/2 - 14
C2404-0502	5/16	1/8 - 27
C2404-0504	5/16	1/4 - 18
C2404-0602	3/8	1/4 - 18
C2404-0604	3/8	1/8 - 27
C2404-0606	3/8	3/8 - 18
C2404-0608	3/8	1/2 - 14
C2404-0804	1/2	3/8 - 18
C2404-0806	1/2	1/4 - 18
C2404-0808	1/2	1/2 - 14
C2404-0812	1/2	3/4 - 14
C2404-1006	5/8	1/2 - 14
C2404-1008	5/8	3/8 - 18
C2404-1208	3/4	3/4 - 14
C2404-1212	3/4	1/2 - 14
C2404-1412	7/8	3/4 - 14
C2404-1612	1	1 - 11 1/2
C2404-1616	1	3/4 - 14
C2404-2020	1 1/4	1 1/4 - 11 1/2
C2404-2424	1 1/2	1 1/2 - 11 1/2
C2404-3232	2	2 - 11 1/2

C2405 FLARELESS / F-NPT

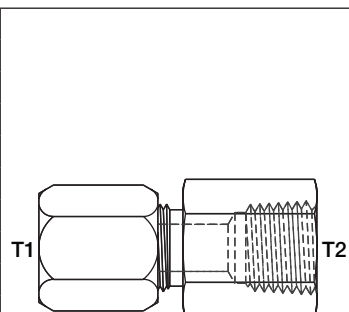

Part Number	T1	T2
C2405-0202	1/8	1/8 - 27
C2405-0402	1/4	1/8 - 27
C2405-0404	1/4	1/4 - 18
C2405-0502	5/16	1/8 - 27
C2405-0604	3/8	1/4 - 18
C2405-0606	3/8	3/8 - 18
C2405-0806	1/2	3/8 - 18
C2405-0804	1/2	1/4 - 18
C2405-0808	1/2	1/2 - 14
C2405-1008	5/8	1/2 - 14
C2405-1212	3/4	3/4 - 14
C2405-1414	7/8	3/4 - 14
C2405-1616	1	1 - 11 1/2
C2405-2020	1 1/4	1 1/4 - 11 1/2

ADAPTERS

C2406 STANDPIPE / FLARELESS REDUCER

	Part Number	T1	T2
	C2406-0604	3/8	1/4
	C2406-0804	1/2	1/4
	C2406-0806	1/2	3/8
	C2406-1008	5/8	1/2
	C2406-1208	3/4	1/2
	C2406-1612	1	3/4
	C2406-2016	1 1/4	1

C2408 FLARELESS PLUG

	Part Number	T1
	C2408-02	1/8
	C2408-04	1/4
	C2408-05	5/16
	C2408-06	3/8
	C2408-08	1/2
	C2408-10	5/8
	C2408-12	3/4
C2408-16	1	

C2500 90° FLARELESS / FLARELESS

	Part Number	T1	T2
	C2500-0303	3/16	3/16
	C2500-0404	1/4	1/4
	C2500-0505	5/16	5/16
	C2500-0606	3/8	3/8
	C2500-0808	1/2	1/2
	C2500-1010	5/8	5/8
	C2500-1212	3/4	3/4
	C2500-1414	7/8	7/8
	C2500-1616	1	1
	C2500-2020	1 1/4	1 1/4
	C2500-2424	1 1/2	1 1/2

ADAPTERS

C2501 90° FLARELESS / M-NPT

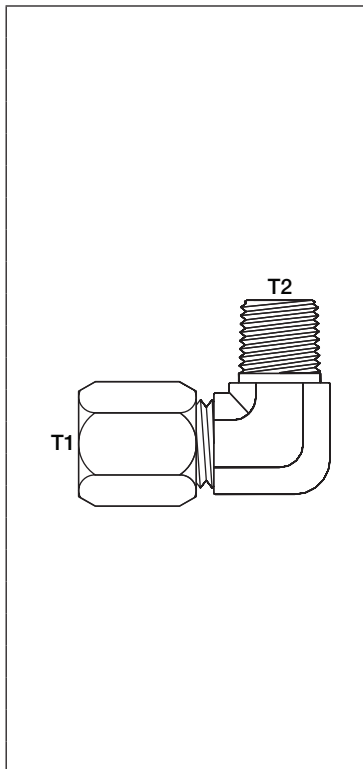

Part Number	T1	T2
C2501-0202	1/8	1/8 - 27
C2501-0302	3/16	1/8 - 27
C2501-0402	1/4	1/8 - 27
C2501-0404	1/4	1/4 - 18
C2501-0502	5/16	1/8 - 27
C2501-0504	5/16	1/4 - 18
C2501-0602	3/8	1/4 - 18
C2501-0604	3/8	1/8 - 27
C2501-0606	3/8	3/8 - 18
C2501-0608	3/8	1/2 - 14
C2501-0806	1/2	3/8 - 18
C2501-0804	1/2	1/4 - 18
C2501-0808	1/2	1/2 - 14
C2501-1008	5/8	1/2 - 14
C2501-1006	5/8	3/8 - 18
C2501-1212	3/4	3/4 - 14
C2501-1208	3/4	1/2 - 14
C2501-1412	7/8	3/4 - 14
C2501-1616	1	1 - 11 1/2
C2501-1612	1	3/4 - 14
C2501-2020	1 1/4	1 1/4 - 11 1/2
C2501-2424	1 1/2	1 1/2 - 11 1/2
C2501-3232	2	2 - 11 1/2

C2502 90° FLARELESS / F-NPT

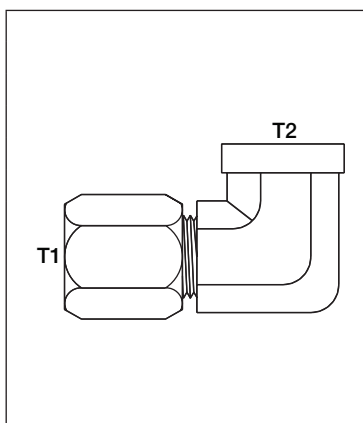

Part Number	T1	T2
C2502-0402	1/4	1/8 - 27
C2502-0404	1/4	1/4 - 18
C2502-0502	5/16	1/8 - 27
C2502-0604	3/8	1/4 - 18
C2502-0606	3/8	3/8 - 18
C2502-0804	1/2	1/4 - 18
C2502-0806	1/2	3/8 - 18
C2502-0808	1/2	1/2 - 14
C2502-1008	5/8	1/2 - 14
C2502-1212	3/4	3/4 - 14
C2502-1414	7/8	3/4 - 14
C2502-1616	1	1 - 11 1/2

ADAPTERS

C2503 45° FLARELESS / M-NPT

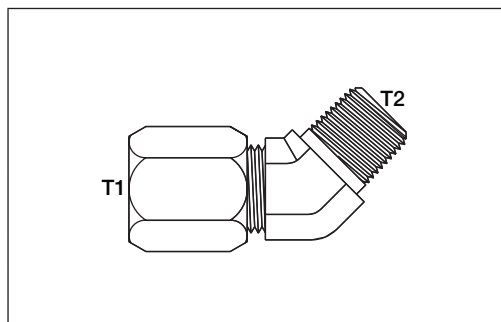

Part Number	T1	T2
C2503-0402	1/4	1/8 - 27
C2503-0404	1/4	1/4 - 18
C2503-0502	5/16	1/8 - 27
C2503-0604	3/8	1/4 - 18
C2503-0806	1/2	3/8 - 18
C2503-0808	1/2	1/2 - 14
C2503-1008	5/8	1/2 - 14
C2503-1212	3/4	3/4 - 14
C2503-1616	1	1 - 11 1/2

C2601 TEE FLARELESS / FLARELESS / M-NPT

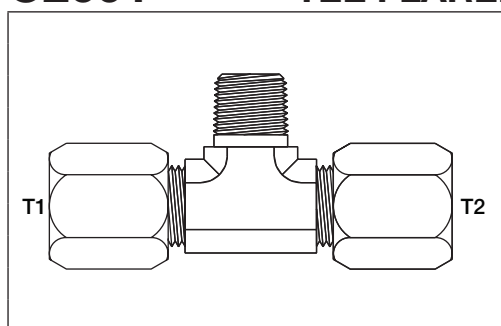

Part Number	T1	T2	T3
C2601-040402	1/4	1/4	1/8 - 27
C2601-040404	1/4	1/4	1/4 - 18
C2601-050502	5/16	5/16	1/8 - 27
C2601-060604	3/8	3/8	1/4 - 18
C2601-080806	1/2	1/2	3/8 - 18
C2601-080808	1/2	1/2	1/2 - 14
C2601-101008	5/8	5/8	1/2 - 14
C2601-121212	3/4	3/4	3/4 - 14
C2601-161616	1	1	1 - 11 1/2

C2602 TEE FLARELESS / FLARELESS / F-NPT

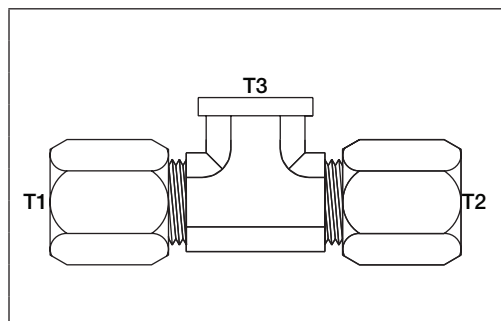

Part Number	T1	T2	T3
C2602-040402	1/4	1/4	1/8 - 27
C2602-040404	1/4	1/4	1/4 - 18
C2602-060604	3/8	3/8	1/4 - 18
C2602-080806	1/2	1/2	3/8 - 18
C2602-080808	1/2	1/2	3/4 - 16
C2602-101008	5/8	5/8	1/2 - 14
C2602-121212	3/4	3/4	3/4 - 14
C2602-161616	1	1	1 - 11 1/2
C2602-202020	1 1/4	1 1/4	1 1/4 - 11 1/2

C2603 TEE FLARELESS

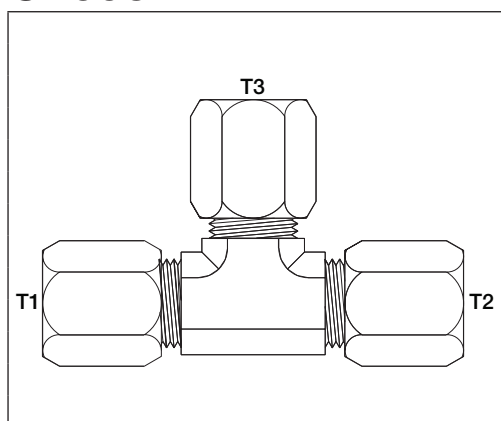

Part Number	T1	T2	T3
C2603-020202	1/8	1/8	1/8
C2603-030303	3/16	3/16	3/16
C2603-040404	1/4	1/4	1/4
C2603-050505	5/16	5/16	5/16
C2603-060606	3/8	3/8	3/8
C2603-080806	1/2	1/2	1/2
C2603-080808	1/2	1/2	3/8
C2603-101010	5/8	5/8	5/8
C2603-121212	3/4	3/4	3/4
C2603-141414	7/8	7/8	7/8
C2603-161616	1	1	1
C2603-202020	1 1/4	1 1/4	1 1/4

ADAPTERS

C2605 TEE FLARELESS / M-NPT / FLARELESS

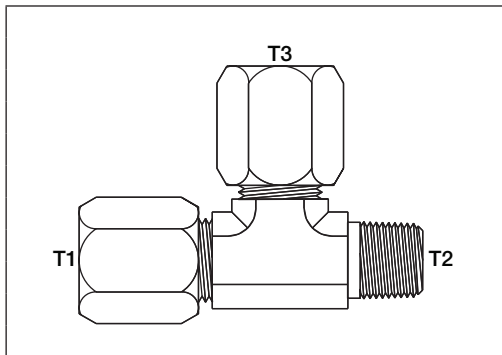

Part Number	T1	T2	T3
C2605-040204	1/4	1/8 - 27	1/4
C2605-040404	1/4	1/4 - 18	1/4
C2605-050205	5/16	1/8 - 27	5/16
C2605-060406	3/8	1/4 - 18	3/8
C2605-060606	3/8	3/8 - 18	3/8
C2605-080608	1/2	3/8 - 18	1/2
C2605-080808	1/2	1/2 - 14	1/2
C2605-100810	5/8	1/2 - 14	5/8
C2605-121212	3/4	3/4 - 14	3/4
C2605-161616	1	1 - 11 1/2	1

C2606 TEE FLARELESS / F-NPT / FLARELESS

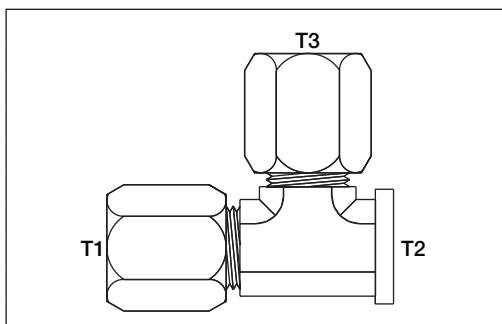

Part Number	T1	T2	T3
C2606-040204	1/4	1/8 - 27	1/4
C2606-040404	1/4	1/4 - 18	1/4
C2606-060406	3/8	1/4 - 18	3/8
C2606-080608	1/2	3/8 - 18	1/2
C2606-100810	5/8	1/2 - 14	5/8
C2606-121212	3/4	3/4 - 14	3/4
C2606-141214	7/8	3/4 - 14	7/8

C2650 CROSS FLARELESS

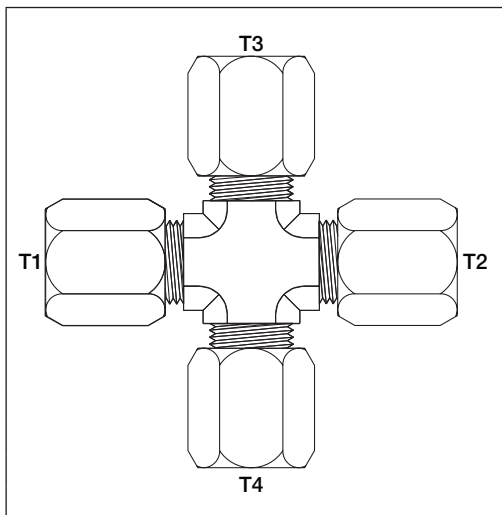

Part Number	T1	T2	T3	T4
C2650-04040404	1/4	1/4	1/4	1/4
C2650-06060606	3/8	3/8	3/8	3/8
C2650-08080808	1/2	1/2	1/2	1/2
C2650-10101010	5/8	5/8	5/8	5/8
C2650-12121212	3/4	3/4	3/4	3/4

ADAPTERS

C2700 FLARELESS / FLARELESS BULKHEAD

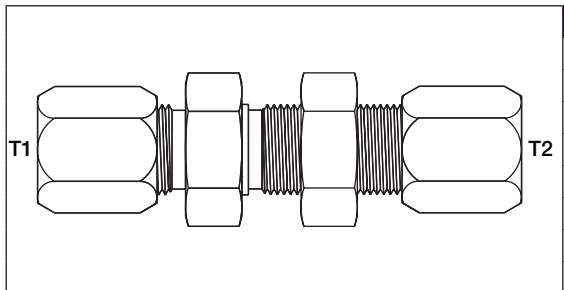

Part Number	T1	T2
C2700-0303	3/16	3/16
C2700-0404	1/4	1/4
C2700-0606	3/8	3/8
C2700-0808	1/2	1/2
C2700-1010	5/8	5/8
C2700-1212	3/4	3/4
C2700-1414	7/8	7/8
C2700-1616	1	1

C6400 FLARELESS / M-ORB

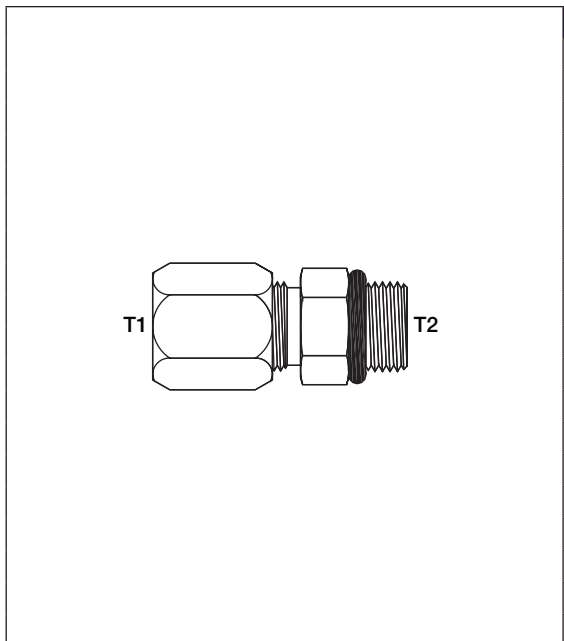

Part Number	T1	T2
C6400-0303	3/16	3/8 - 24
C6400-0404	1/4	7/16 - 20
C6400-0405	1/4	1/2 - 20
C6400-0406	1/4	9/16 - 18
C6400-0505	5/16	1/2 - 20
C6400-0606	3/8	9/16 - 18
C6400-0608	3/8	3/4 - 16
C6400-0806	1/2	9/16 - 18
C6400-0808	1/2	3/4 - 16
C6400-0810	1/2	7/8 - 14
C6400-0812	1/2	1 1/16 - 12
C6400-1010	5/8	7/8 - 14
C6400-1212	3/4	1 1/16 - 12
C6400-1216	3/4	1 5/16 - 12
C6400-1612	1	1 1/16 - 12
C6400-1616	1	1 5/16 - 12
C6400-2020	1 1/4	1 5/8 - 12
C6400-2424	1 1/2	1 7/8 - 12
C6400-3232	2	2 1/2 - 12

C6400L FLARELESS / M-ORB LONG

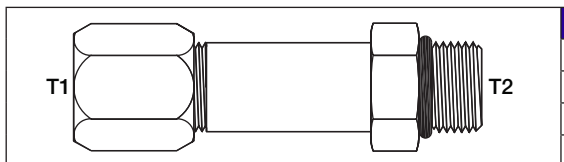

Part Number	T1	T2
C6400L-0404	1/4	7/16 - 20
C6400L-0606	3/8	9/16 - 18
C6400L-0808	1/2	3/4 - 16
C6400L-1010	5/8	7/8 - 14

ADAPTERS

C6801 90° FLARELESS / M-ORB

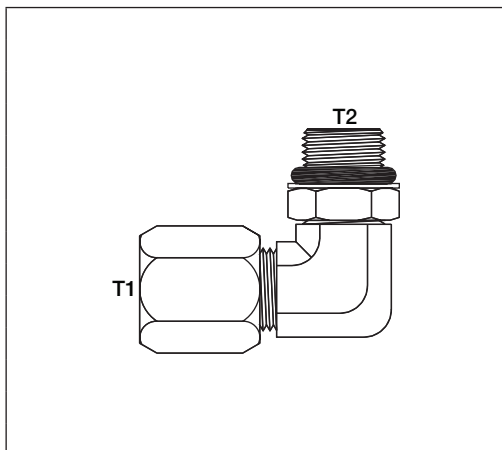

Part Number	T1	T2
C6801-0404	1/4	7/16 - 20
C6801-0505	5/16	1/2 - 20
C6801-0606	3/8	9/16 - 18
C6801-0608	3/8	3/4 - 16
C6801-0806	1/2	9/16 - 18
C6801-0808	1/2	3/4 - 16
C6801-0810	1/2	7/8 - 14
C6801-0812	1/2	1 1/16 - 12
C6801-1010	5/8	7/8 - 14
C6801-1208	3/4	3/4 - 16
C6801-1212	3/4	1 1/16 - 12
C6801-1616	1	1 5/16 - 12
C6801-2020	1 1/4	1 5/8 - 12

C6802 45° FLARELESS / M-ORB

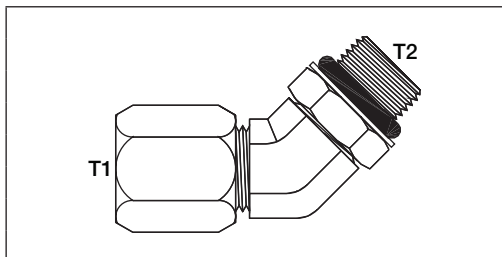

Part Number	T1	T2
C6802-0808	1/2	3/4 - 16
C6802-1212	3/4	1 1/16 - 12
C6802-1616	1	1 5/16 - 12

C6803 TEE FLARELESS / FLARELESS / M-ORB

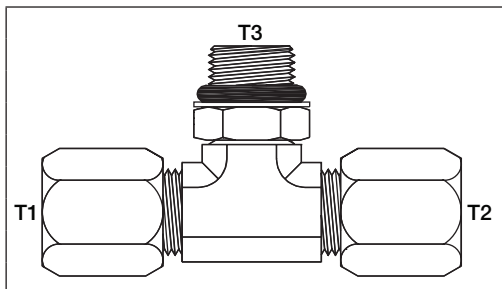

Part Number	T1	T2	T3
C6803-040404	1/4	1/4	7/16 - 20
C6803-060606	3/8	3/8	9/16 - 18
C6803-080808	1/2	1/2	3/4 - 16

C6804 TEE M-ORB / FLARELESS / FLARELESS

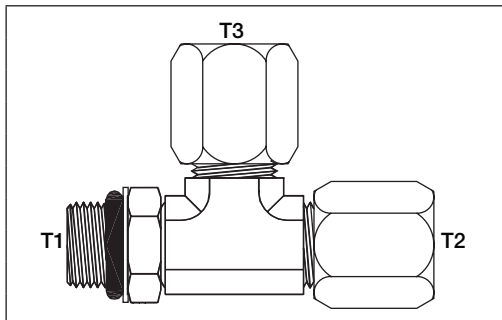

Part Number	T1	T2	T3
C6804-04	7/16 - 20	1/4	1/4
C6804-06	9/16 - 18	3/8	3/8
C6804-08	3/4 - 16	1/2	1/2

ACCESSORIES

NYLON SLEEVING

- Ideal for abrasion protection or bundling hose assemblies
- MSHA approved
- Temperature range: -40°F to 250°F

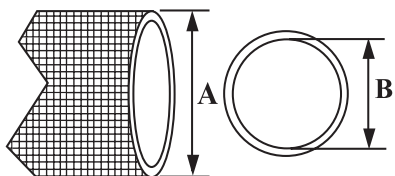

Part Number	Flat Width A (in)	Nominal ID B (in)	Standard Package (ft)
NS-071	1.12	0.71	300
NS-077	1.25	0.77	300
NS-082	1.30	0.82	300
NS-090	1.50	0.90	300
NS-100	1.66	1.00	300
NS-113	1.75	1.13	300
NS-125	2.05	1.25	300
NS-130	2.15	1.30	300
NS-142	2.34	1.42	300
NS-159	2.56	1.59	300
NS-178	2.90	1.78	300
NS-191	3.10	1.91	300
NS-206	3.37	2.06	300
NS-219	3.63	2.19	300
NS-238	3.81	2.38	300
NS-265	4.28	2.65	300
NS-293	4.47	2.93	300
NS-334	5.25	3.34	300
NS-366	5.81	3.66	300

NOTE: Other sizes are available upon request

POLYURETHANE SLEEVING

- Ideal for abrasion protection or bundling hose assemblies
- MSHA approved
- Temperature range: -40°F to 250°F

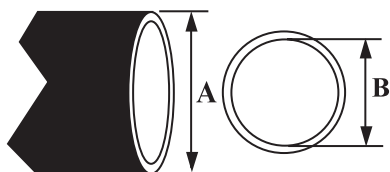

Black Part Number	Yellow Part Number	Wall Thickness (in)	Nominal ID B (in)	Standard Package (ft)
PS-0625B	PS-0625Y	0.045	0.625	30
PS-0750B	PS-0750Y	0.045	0.750	30
PS-0875B	PS-0875Y	0.045	0.875	30
PS-1000B	PS-1000Y	0.045	1.000	30
PS-1125B	PS-1125Y	0.045	1.125	30
PS-1250B	PS-1250Y	0.045	1.250	30
PS-1375B	PS-1375Y	0.045	1.375	30
PS-1500B	PS-1500Y	0.045	1.500	30
PS-1625B	PS-1625Y	0.045	1.625	30
PS-1750B	PS-1750Y	0.045	1.750	30
PS-2000B		0.060	2.000	30
	PS-2125Y	0.060	2.125	30

NOTE: Other sizes are available upon request

ACCESSORIES

PLASTIC WRAP - MEDIUM DUTY

- Ideal for abrasion protection or bundling hose assemblies
- Temperature Range: -50°C to 175°F



Black Part Number	Yellow Part Number	ID (in)	Wall Thickness	Length (ft)
PWMD-040B	PWMD-040Y	0.40	0.05	100
PWMD-050B	PWMD-050Y	0.50	0.05	100
PWMD-065B	PWMD-065Y	0.65	0.08	100
PWMD-080B	PWMD-080Y	0.80	0.09	100
PWMD-110B	PWMD-110Y	1.10	0.10	100
PWMD-140B	PWMD-140Y	1.40	0.11	100
PWMD-170B	PWMD-170Y	1.70	0.13	100
PWMD-220B	PWMD-220Y	2.20	0.15	100
PWMD-260B	PWMD-260Y	2.60	0.17	75
PWMD-320B	PWMD-320Y	3.20	0.19	50
PWMD-390B	PWMD-390Y	3.90	0.22	50
PWMD-450B	PWMD-450Y	4.50	0.23	40
PWMD-500B	PWMD-500Y	5.00	0.26	30

PRE-CUT PACKAGE - MEDIUM DUTY



Black Part Number	Yellow Part Number	ID (in)	Length (ft)
PWMD-040B-PCP	PWMD-040Y-PCP	0.40	25
PWMD-050B-PCP	PWMD-050Y-PCP	0.50	25
PWMD-065B-PCP	PWMD-065Y-PCP	0.65	25
PWMD-080B-PCP	PWMD-080Y-PCP	0.80	25
PWMD-110B-PCP	PWMD-110Y-PCP	1.10	25
PWMD-140B-PCP	PWMD-140Y-PCP	1.40	12
PWMD-170B-PCP	PWMD-170Y-PCP	1.70	10

PLASTIC WRAP - HEAVY DUTY

- Ideal for abrasion protection or bundling hose assemblies
- Temperature range: -50°F to 175°F



Black Part Number	Yellow Part Number	Wall Thickness (in)	ID (in)	Length (ft)
PW-050B	PW-050Y	0.069	0.50	100
PW-075B	PW-075Y	0.122	0.75	100
PW-100B	PW-100Y	0.118	1.00	100
PW-125B	PW-125Y	0.132	1.25	100
PW-150B	PW-150Y	0.140	1.50	100
PW-200B	PW-200Y	0.160	2.00	100
PW-250B	PW-250Y	0.209	2.50	50
PW-300B	PW-300Y	0.218	3.00	35
PW-350B	PW-350Y	0.250	3.50	25
PW-400B	PW-400Y	0.250	4.00	20
PW-600B	PW-600Y	0.250	6.00	15

ACCESSORIES

STEEL SPRING GUARD

- Ideal for abrasion protection or bundling hose assemblies

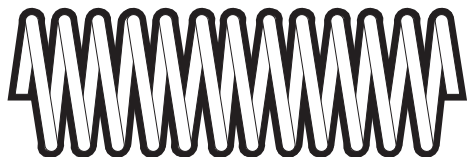

Part Number	ID (in)	Pitch	Wire Gauge	Length /Box
SG-0515	0.515	7/31	0.080	1 x 25'
SG-0550	0.550	7/32	0.080	1 x 25'
SG-0650	0.650	7/32	0.080	1 x 25'
SG-0750	0.750	7/32	0.080	1 x 25'
SG-0835	0.835	7/32	0.080	1 x 25'
SG-0900	0.900	7/32	0.080	1 x 25'
SG-0990	0.990	7/32	0.080	1 x 25'
SG-1055	1.055	7/32	0.080	1 x 25'
SG-1100	1.100	7/32	0.080	1 x 25'
SG-1240	1.240	11/32	0.120	1 x 25'
SG-1300	1.300	11/32	0.120	1 x 25'
SG-1380	1.380	11/32	0.120	1 x 25'
SG-1630	1.630	11/32	0.120	1 x 25'
SG-1810	1.810	11/32	0.120	1 x 25'
SG-2000	2.000	11/32	0.120	1 x 25'
SG-2125	2.125	11/32	0.120	2 x 10'
SG-2300	2.300	11/32	0.120	2 x 10'
SG-2500	2.500	11/32	0.120	2 x 10'
SG-2900	2.900	11/32	0.120	2 x 10'
SG-3000	3.000	11/32	0.120	2 x 10'
SG-3350	3.350	11/32	0.120	2 x 10'

FIRE SLEEVING

- Continuous exposure: 500°F (260°C)
- 2000°F (1090°C) for 15-20 minutes
- 3000°F (1650°C) for 15-20 seconds
- Fibreglass sleeve coated with red silicone rubber
- Protects hoses from molten metal splash, intense heats and flame



Part Number	Nominal ID B (in)	Standard Package (ft)
FS-050	0.50	50
FS-063	0.63	50
FS-075	0.75	50
FS-088	0.88	50
FS-100	1.00	50
FS-113	1.13	50
FS-138	1.38	50
FS-163	1.63	50
FS-175	1.75	50
FS-200	2.00	50

NOTE: Other sizes are available upon request

Fire Sleeve Tape

- PST-16 1" WIDE
- PST-24 1½" WIDE

STRAIN RELIEVERS



- Strain Relievers reduce bending stress near hose end for longer hose life.

Part Number	Hose Type
TPG-04A	¼" ONE WIRE
TPG-06A	⅜" ONE WIRE
TPG-08A	½" ONE WIRE

FLAT ARMOR GUARD

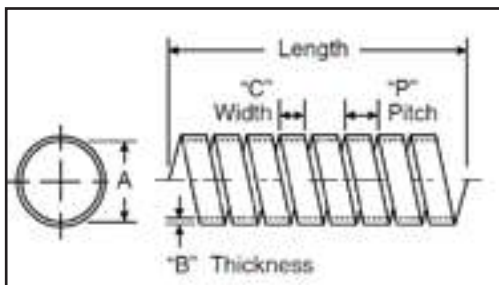

Part Number	A (in) (+.015)	B (in)	C (in)	P (in)
FSG-044	0.441	0.028	0.250	0.370
FSG-050	0.500	0.028	0.250	0.370
FSG-057	0.570	0.028	0.250	0.370
FSG-063	0.625	0.028	0.250	0.370
FSG-075	0.750	0.028	0.250	0.370
FSG-088	0.875	0.028	0.250	0.370
FSG-090	0.900	0.028	0.500	0.690
FSG-099	0.990	0.028	0.500	0.690
FSG-103	1.031	0.028	0.500	0.690
FSG-111	1.110	0.028	0.500	0.690
FSG-122	1.219	0.028	0.500	0.690
FSG-130	1.300	0.028	0.500	0.690
FSG-138	1.380	0.028	0.500	0.690
FSG-147	1.469	0.028	0.500	0.810
FSG-163	1.630	0.028	0.500	0.810
FSG-169	1.688	0.028	0.500	0.810
FSG-191	1.906	0.028	0.500	0.810
FSG-213	2.130	0.028	0.500	0.810
FSG-230	2.300	0.028	0.500	0.810
FSG-256	2.562	0.028	0.500	0.810

ACCESSORIES

OK O-RING KITS



These kits contain the most popular size 90 durometer O-rings, individually boxed, which will supply your shop, service truck, or parts counter with the size you need.

O-RING KITS	Part Number
O-Ring Boss Kit	OK-10
O-Ring Face Seal Kit	OK-20
SAE Flange O-Ring Kit	OK-30
Caterpillar Flange O-Ring Kit	OK-40
O-Ring Boss, Face Seal & SAE Flange Kit	OK-60
O-Ring Boss, Face Seal & SAE Flange Kit (Brown Viton)	OK-60BV90
European Metric Standard O-Ring Kit	OK-60EB90
Japanese Metric Standard O-Ring Kit	OK-60JB90

These replacement O-rings are made from buna-N nitrile rubber and are resistant to gasoline, oil, grease, and petroleum based hydraulic fluids. Other O-ring materials can be special ordered. Match the O-ring dash size to the dash size of the fitting.

PCDK CAP AND PLUG KITS



These kits contain the following:

- JIC Caps
- NPT Caps
- ORFS Cap
- MORB Plugs
- JIC Plugs
- NPT Plugs
- ORFS Plugs

CAP AND PLUG KITS	Part Number
Domestic Cap & Plug Kit	PCDK-45

MTK-31 METRIC THREAD ID KIT



Thread Identification Kits for male and female threads include:

- M8 x 1.0 through M52 x 2.0 metric thread gauges
- 1/8-28 BSPP through 2-11 BSPP thread gauges
- Thread and port guide
- 31 dual threaded heat treated aluminum gauges

CAP AND PLUG KITS	Part Number
Metric Thread ID Kit	MTK-31

BOSS O-RINGS

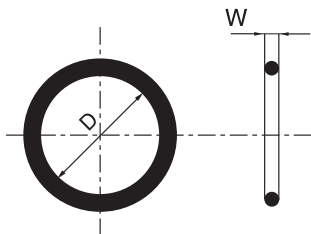

Part Number	O-Ring ID	Wall Dia.
OB-02	0.239	0.064
OB-03	0.301	0.064
OB-04	0.351	0.072
OB-05	0.414	0.072
OB-06	0.468	0.078
OB-08	0.644	0.087
OB-10	0.755	0.097
OB-12	0.924	0.116
OB-14	1.048	0.116
OB-16	1.170	0.116
OB-20	1.475	0.118
OB-24	1.720	0.118
OB-32	2.337	0.118

FACE SEAL O-RINGS

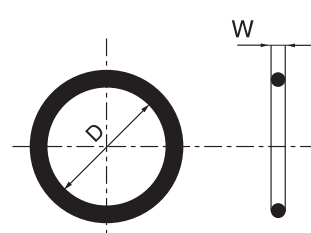

Part Number	O-Ring ID	Wall Dia.
OR-04	0.301	0.070
OR-06	0.364	0.070
OR-08	0.489	0.070
OR-10	0.614	0.070
OR-12	0.739	0.070
OR-16	0.926	0.070
OR-20	1.176	0.070
OR-24	1.489	0.070

NOTE: Other sizes are available upon request

SAE FLANGE O-RINGS

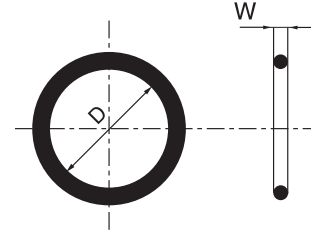

Part Number	O-Ring ID	Wall Dia.
OF-08	0.734	0.139
OF-12	0.984	0.139
OF-16	1.296	0.139
OF-20	1.484	0.139
OF-24	1.859	0.139
OF-32	2.234	0.139

NOTE: Other sizes are available upon request

CATERPILLAR FLANGE D-RINGS

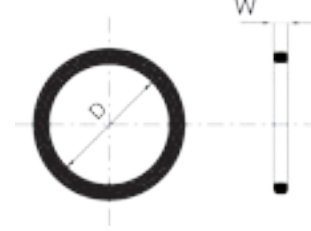

Part Number	O-Ring ID	Wall Dia.
OD-08	0.734	0.139
OD-12	0.984	0.139
OD-16	1.296	0.139
OD-20	1.484	0.139
OD-24	1.859	0.139
OD-32	2.234	0.139

NOTE: Other sizes are available upon request

ACCESSORIES

STOPFLEX® NIPPLE RETENTION SYSTEM



Part Number	Eyelet ID Inches	Eyelet Thickness Inches	Cable Length Inches	Number of PCS	Maximum PSI
STOPFUDIN145	0.571	0.079	12	10	6525
STOPFUDIN17	0.669	0.079	12	10	6453
STOPFUDIN185	0.728	0.079	12	10	6090
STOPFUDIN205	0.807	0.079	12	10	6090
STOPFUDIN225	0.886	0.079	12	10	6090
STOPFUDIN245	0.965	0.079	12	10	6090
STOPFUDIN265	1.043	0.079	12	10	6090
STOPFUDIN305	1.291	0.098	12	10	6090
STOPFUDIN34	1.339	0.098	18	10	6090
STOPFUDIN365	1.437	0.098	18	10	6090
STOPFUDIN425	1.673	0.098	18	10	6090
STOPFUDIN455	1.791	0.098	18	10	6090
STOPFUDIN49	1.929	0.098	18	10	6090
STOPFUDIN525	2.067	0.098	18	10	6090
STOPFUDIN60	2.362	0.098	18	10	6090

STOPFLEX® RETENTION SYSTEM FOR SAE 3000 & SAE 6000 FLANGES



Part Number	Eyelet ID Inches	Eyelet Thickness Inches	Cable Length Inches	Number of PCS	Maximum PSI
STOPFUSAE085	0.335	0.157	12	10	6018
STOPFUSAE2105	0.413	0.157	12	10	6090
STOPFUSAE105	0.413	0.157	18	10	6090
STOPFUSAE125	0.492	0.157	18	10	6090
STOPFUSAE145	0.571	0.157	18	10	6090
STOPFUSAE165	0.650	0.157	18	10	6090
STOPFUSAE205	0.807	0.157	18	10	5075
STOPFUSAE25	0.984	0.315	22	10	5075
STOPFUSAE32	1.260	0.315	22	10	3045

STOPFLEX® RETENTION SYSTEM FOR VARIOUS USES



Part Number	Eyelet ID Inches	Eyelet Thickness Inches	Cable Length Inches	Number of PCS	Maximum PSI
STOPFUVARIE	0.512	0.157	18	10	6090

STOPFLEX® HOSE BANDS



Part Number	Minimum		Maximum		No. of PCS
	mm	in	mm	in	
STOPFA11115	11	0.433	11.5	0.453	10
STOPFA12125	12	0.472	12.5	0.492	10
STOPFA13135	13	0.512	13.5	0.531	10
STOPFA1415	14	0.551	15	0.591	10
STOPFA1617	16	0.630	17	0.669	10
STOPFA1718	17	0.669	18	0.709	10
STOPFA1819	18	0.709	19	0.748	10
STOPFA2021	20	0.787	21	0.827	10
STOPFA2122	21	0.827	22	0.866	10
STOPFA2223	22	0.866	23	0.906	10
STOPFA2425	24	0.945	25	0.984	10
STOPFA2526	25	0.984	26	1.024	10
STOPFA2627	26	1.024	27	1.063	10
STOPFA2728	27	1.063	28	1.102	10
STOPFA2829	28	1.102	29	1.142	10
STOPFA3031	30	1.181	31	1.220	10
STOPFA3233	32	1.260	33	1.299	10
STOPFA3435	34	1.339	35	1.378	10
STOPFA3637	36	1.417	37	1.457	10
STOPFA3839	38	1.496	39	1.535	10
STOPFA3940	39	1.535	40	1.575	10
STOPFA4041	40	1.575	41	1.614	10
STOPFA4243	42	1.654	43	1.693	10
STOPFA4344	43	1.693	44	1.732	10
STOPFA4445	44	1.732	45	1.772	10
STOPFA4547	45	1.772	47	1.850	10
STOPFA4850	48	1.890	50	1.969	10
STOPFA5153	51	2.008	53	2.087	10
STOPFA5354	53	2.087	54	2.126	10
STOPFA5456	54	2.126	56	2.205	10
STOPFA5759	57	2.244	59	2.323	10
STOPFA6062	60	2.362	62	2.441	10
STOPFA6365	63	2.480	65	2.559	10
STOPFA6668	66	2.598	68	2.677	10
STOPFA6971	69	2.717	71	2.795	10
STOPFA7274	72	2.835	74	2.913	10
STOPFA7577	75	2.953	77	3.031	10
STOPFA7880	78	3.071	80	3.150	10
STOPFA8183	81	3.189	83	3.268	10
STOPFA8486	84	3.307	86	3.386	10
STOPFA8789	87	3.425	89	3.504	10
STOPFA9092	90	3.543	92	3.622	10
STOPFA9395	93	3.661	95	3.740	10

ACCESSORIES

HOSE HANDLE CLAMPS



Part Number	Clamp Size Inches
HC-200-H	2"
HC-300-H	3"
HC-400-H	4"
HC-600-H	6"
HC-800-H	8"
HC-1000-H	10"
HC-1200-H	12"

CAMLOCK VELCRO STRAPS



Part Number	Hose Strap Inches
CGVS-19	19"
CGVS-30	30"

EQUIPMENT



FLEUTRAL

EQUIPMENT

FX17E

The **FX17E** is designed to be used as either a bench mount or as a portable crimping machine. This is a versatile and cost effective crimping machine with it's ability to crimp hoses thru 1" 6-Spiral.

Capacity:

Teflon Hose $\frac{3}{16}$ " thru 1"
 Thermoplastic Hose $\frac{3}{16}$ " thru 1"
 Air Conditioning Hose $\frac{5}{16}$ " thru $\frac{5}{8}$ "
 1-Wire Braid Hose $\frac{3}{16}$ " thru 1"
 2-Wire Braid Hose $\frac{1}{4}$ " thru 1"
 4-Spiral Hose $\frac{3}{8}$ " thru 1"
 6-Spiral Hose $\frac{3}{8}$ " thru 1"

The **FX17E** - supplied with a 1HP 110V pump.

Size: 11" wide, 20" deep, 19" high

Weight: Approx. 125 lbs.

FX17A / FX17H



The **FX17A** is supplied with a 10,000 PSI air over hydraulic pump.

The **FX17H** is supplied with a 10,000 PSI hand over hydraulic pump.

Size: 13.5" wide, 14" deep, 15" high

Weight: Approx. 66 lbs.

Dies & Spacer Rings:

The FX17 requires FX17 Series crimp dies and spacer rings.

Caution - All Flextral pumps produce 10,000 PSI. Safety and caution should always be used when operating hydraulic equipment.

FX17LWP

The **FX17LWP** is a powerful, compact and portable crimping machine.



Capacity:

- Teflon Hose $\frac{3}{16}$ " thru 1"
- Thermoplastic Hose $\frac{3}{16}$ " thru 1"
- Air Conditioning Hose $\frac{5}{16}$ " thru $\frac{5}{8}$ "
- 1-Wire Braid Hose $\frac{3}{16}$ " thru 1"
- 2-Wire Braid Hose $\frac{1}{4}$ " thru 1"
- 4-Spiral Hose $\frac{3}{8}$ " thru $\frac{3}{4}$ "

The **FX17LWPA** - is supplied with a 10,000 PSI air over hydraulic pump.

The **FX17LWPE** - is supplied with a 1HP 110V pump.

The **FX17LWPH** - is supplied with a 10,000 PSI hand over hydraulic pump.

Size: 10" wide, 18" deep, 18" high

Weight: Approx. 45 lbs. without pump.

EQUIPMENT

FX21FBE *FAT BOY*

The **FX21FBE** is also known as the FAT BOY. It gets its name from its wide looking design. It is designed as a portable crimping machine but can just as easily be used as a bench mount unit. The FAT BOY touts a robust 1¼" 6-Spiral capacity.

Capacity:

Teflon Hose ¾" thru 1"
 Thermoplastic Hose ¾" thru 1"
 Air Conditioning Hose ¾" thru 5/8"
 1-Wire Braid Hose ¾" thru 1¼"
 2-Wire Braid Hose ¼" thru 1¼"
 4-Spiral Hose ¾" thru 1¼"
 6-Spiral Hose ½" thru 1¼"

The **FX21FBE-1.0** - supplied with a 1HP 110V pump.

The **FX21FBE-2.0** - supplied with a 2HP 220V pump.

Size: 15.5" wide, 14" deep, 20" high

Weight: Approx. 112 lbs.

FX21FBA / FX21FBH



The **FX21FBA** is supplied with a 10,000 PSI air over hydraulic pump.

The **FX21FBH** is supplied with a 10,000 PSI hand over hydraulic pump.

Size: 15.5" wide, 14" deep, 20" high

Weight: Approx. 112 lbs.

Dies & Spacer Rings:

The FX21FB requires FX21 Series crimp dies and spacer rings.

Caution - All Flextral pumps produce 10,000 PSI. Safety and caution should always be used when operating hydraulic equipment.

FX21

The **FX21** is the staple crimper of any proficient hose shop. Not only is it perfectly engineered, but it is the most user friendly crimping system on the market today.

The **FX21** is designed as a “dead stop” crimping system. It has no electronics, requires no calibration and has no dials to set. Simply select the proper die and spacer ring and crimp away. This machine is the maintenance man’s best friend.



Capacity:

Teflon Hose $\frac{3}{16}$ " thru 1"
 Thermoplastic Hose $\frac{3}{16}$ " thru 1"
 Air Conditioning Hose $\frac{5}{16}$ " thru $\frac{5}{8}$ "
 1-Wire Braid Hose $\frac{3}{16}$ " thru $1\frac{1}{4}$ "
 2-Wire Braid Hose $\frac{1}{4}$ " thru $1\frac{1}{4}$ "
 4-Spiral Hose $\frac{3}{8}$ " thru $1\frac{1}{4}$ "
 6-Spiral Hose $\frac{1}{2}$ " thru $1\frac{1}{4}$ "

The **FX21** is available in two electric pump configurations:

FX21-1 - Press and pump assembly with a 1 H.P. 110 V electric over hydraulic pump.

FX21-2 - Press and pump assembly with a 2 H.P. 110 V electric over hydraulic pump.

Size: 16" wide, 32" deep, 33" high

Weight: Approx. 290 lbs.

Dies & Spacer Rings:

The FX21 requires FX21 Series crimp dies and spacer rings.

Caution - All Flextral pumps produce 10,000 PSI. Safety and caution should always be used when operating hydraulic equipment.

EQUIPMENT

FX21E

The FX21E is the latest addition to the FX21 crimper series. It is engineered with same durability and simplicity but with the addition of digital control. The digital control eliminates the need for multiple spacer rings and enables the user to update the PLC via a USB port. The control module is pre-programmed with the most common Flextral hose and fittings. In addition the crimper can be operated in the variable mode enabling the user to select a fixed crimp diameter.

Capacity:

Teflon Hose 3/16" thru 1"
 Thermoplastic Hose 3/16" thru 1"
 Air Conditioning Hose 5/16" thru 5/8"
 1 Wire Braid hose 3/16" thru 1 1/4"
 2 Wire Braid hose 1/4" thru 1 1/4"
 4 Spiral Hose 3/8" thru 1 1/4"
 6 Spiral Hose 1/2" thru 1 1/4"

FX21E-1 Press and Pump assembly with 1HP 110v electric over hydraulic pump. Includes foot switch with guard and calibration ring.

Size: 16" wide, 32" deep, 33" high

Weight: approximately 300lb.

Dies and Spacer Rings:

The FX21E requires FX21 series crimp dies and one common spacer ring (spacer ring YY).

FX41 THE BOSS

The FX41 is also known as THE BOSS. It is designed as a “dead stop” crimping system. It requires no calibration and has no dials to set. It has the ability to crimp through 2” 6-spiral hose. Its front loading system allows the user convenient access and ease of use throughout the crimping process.

FX41-3.0RC - Press and pump assembly with a 3 HP 220V single phase pump mounted on a rolling bench.



FX41-3.0WB - Press and pump assembly with a 3 HP 220V single phase pump designed for bench mounting.

Capacity:

- Teflon Hose $\frac{3}{16}$ " thru 1"
- Thermoplastic Hose $\frac{3}{16}$ " thru 1"
- Air Conditioning Hose $\frac{5}{16}$ " thru $\frac{5}{8}$ "
- Suction & Return Hose thru 2 $\frac{1}{2}$ "
- 1-Wire Braid Hose $\frac{3}{16}$ " thru 2"
- 2-Wire Braid Hose $\frac{1}{4}$ " thru 2"
- 4-Spiral Hose $\frac{3}{8}$ " thru 2"
- 6-Spiral Hose $\frac{1}{2}$ " thru 2"

Note: The FX41 is also available with a 2 H.P. single phase pump.

Caution - All Flextral pumps produce 10,000 PSI. Safety and caution should always be used when operating hydraulic equipment.

EQUIPMENT

FX200

The FX200 series 2" crimper is a stable and reliable workshop crimper. The digital control panel is user friendly and simple enough for the most inexperienced hose assembler. The build quality and reliability is everything you have come to expect from a Flextral crimper.



Specifications:

Crimping Force:	225 Tons
Crimping Range:	6mm - 87mm
Max Hose Diameter (2 Wire):	2"
Max Hose Diameter (4 Wire):	2"
Max Die Opening (Die Size plus):	+32mm
Length:	24"
Width:	19"
Height:	52"
Weight:	772lbs w/o oil
Electrical Power (Std):	220V 3 Ph
Electrical Power (Optional):	220V 1 Ph
Electrical Power (Optional):	440V 3 Ph
Manual/Fully Automatic Crimping:	Yes
Approximate Crimps per Hour (1):	1000

Standard dies included: 14mm, 16mm, 19mm, 22mm, 24mm, 26mm, 30mm, 34mm, 39mm, 48mm, 56mm, and 69mm

(1) Based upon -8 100R2AT hose with 1 pc style fitting.
Specifications are for reference only.

FX300

The FX300 series 3" crimper is the standard when it comes to production crimpers. The digital control panel is user friendly and simple enough for the most inexperienced hose assembler. The build quality and reliability is everything you have come to expect from a Flextral crimper.



Specifications:

Crimping Force:	245 Tons
Crimping Range:	6mm-120mm
Max Hose Diameter (2 Wire):	2"
Max Hose Diameter (4 Wire):	2"
Max Hose Diameter (6 Wire):	2"
Max Industrial Hose Diameter:	3"
Max Die Opening (Die Size plus):	+65mm
Length:	34"
Width:	40"
Height:	60"
Weight:	2205 lbs
Electrical Power (Std):	220V 1Ph
Electrical Power (Optional):	220V 3Ph
Electrical Power (Optional):	440V 3Ph
Manual/Fully Automatic Crimping:	Yes
Approximate Crimps per Hour (1):	2400

*Automatic Backstop Included

Standard dies included: 12mm, 14mm, 16mm, 19mm, 22mm, 26mm, 30mm, 34mm, 39mm, 45mm, 51mm, 57mm, 63mm, 69mm, 74mm, and 78mm

(1) Based upon -8 100R2AT hose with 1 pc style fitting. Specifications are for reference only.

EQUIPMENT

FX400

The FX400 series crimper is ideal for the shop that needs power and capacity. The easy micrometer setting, built in die storage and included foot switch make this crimper ideal for many applications.



(1) Based upon -8 100R2AT hose with 1 pc style fitting.
Specifications are for reference only.

Specifications:

Master Die I.D. (Standard):	145mm
Crimping Force:	265 Ton
Max Hose Diameter (2 Wire):	2"
Max Hose Diameter (4 Wire):	2"
Max Hose Diameter (6 Wire):	2"
Max Industrial Hose Diameter:	4"
Max Die Opening (Die Size plus):	60mm
Max Die Opening w/o Dies:	182mm
Length:	29"
Width:	20"
Height:	32"
Weight:	579 lbs
Electrical Power (Std):	230V 1 Ph
Electrical Power (Optional):	230V 3 Ph
Electrical Power (Optional):	440V 3 Ph
Pump HP:	5 HP
Manual/Fully Automatic Crimping:	Yes
Inch/Metric Settings:	Yes
Approximate Crimps per Hour (1):	1415

Standard dies included: 12mm, 14mm, 16mm, 19mm, 22mm, 26mm, 30mm, 34mm, 39mm, 45mm, 51mm, 57mm, 63mm, 69mm, 74mm, 84mm, 92mm and 145/99mm adapter dies.

Additional 99mm die series available in bore sizes: 7mm – 78mm

Additional 145mm die series available in bore sizes: 84mm - 126mm

FX1200

The FX1200 series 12" crimper is the latest edition to the Flextral equipment line. The digital control panel is user friendly and simple enough for the most inexperienced hose assembler. The build quality and reliability is everything you have come to expect from a Flextral crimper.



Specifications:

Crimping Range(mm):	6mm - 350mm
Crimping Force:	850 Tons
Max Hose Diameter (2 Wire):	3"
Max Hose Diameter (4 Wire):	3"
Max Hose Diameter (6 Wire):	3"
Max Industrial Hose Diameter:	12"
Max Die Opening (Die Size Plus):	+155
Diminsions:	Crimper/Power Unit
Length:	49"/46"
Width:	47"/37"
Height:	71"/51"
Weight:	9900lbs/1320lbs
Electrical Power (Std):	480V 3 Ph
Electrical Power (Optional):	220V 3 Ph
Manual/Fully Automatic Crimping:	Yes
Crimping/Hour:	1200

Standard dies included: All dies are custom ordered according to requirements.

(1) Based upon -8 100R2AT hose with 1 pc style fitting.
Specifications are for reference only.

EQUIPMENT

Weatherhead Conversion Kits

FXT-400



The Weatherhead T-400 can be very simply converted to crimp Flextral products with this easy to use conversion kit.

The FXT-400 includes:

FXT-400PT Push tube

FXT-400DB Die Bowl

FXT-400SH Blue Flextral Shroud with crimp chart

Dies & Spacer Rings:

The FXT-400 requires FX17 Series crimp dies and spacer rings.

Capacity:

Teflon Hose $\frac{3}{16}$ " thru 1"

Thermoplastic Hose $\frac{3}{16}$ " thru 1"

Air Conditioning Hose $\frac{5}{16}$ " thru $\frac{5}{8}$ "

1-Wire Braid Hose $\frac{3}{16}$ " thru 1"

2-Wire Braid Hose $\frac{1}{4}$ " thru 1"

FXT-420



The Weatherhead T-420 can be very simply converted to crimp Flextral products with this easy to use conversion kit.

The FXT-420 includes:

FX21DBI Die Bowl

FXT-420SH Blue Flextral Shroud with crimp chart

Dies & Spacer Rings:

The FXT-420 requires FX21 Series crimp dies and spacer rings.

Capacity:

Teflon Hose $\frac{3}{16}$ " thru 1"

Thermoplastic Hose $\frac{3}{16}$ " thru 1"

Air Conditioning Hose $\frac{5}{16}$ " thru $\frac{5}{8}$ "

1-Wire Braid Hose $\frac{3}{16}$ " thru $\frac{1}{4}$ "

2-Wire Braid Hose $\frac{1}{4}$ " thru $\frac{1}{4}$ "

4-Spiral Hose $\frac{3}{8}$ " thru $\frac{1}{4}$ "

6-Spiral Hose $\frac{1}{2}$ " thru $\frac{1}{4}$ "

FXT-480



The Weatherhead T-480 can be very simply converted to crimp Flextral products with this easy to use conversion kit.

The FXT-480 includes:

FX21DBI Die Bowl

Dies & Spacer Rings:

The FXT-480 requires FX21 Series crimp dies and spacer rings.

Capacity:

Teflon Hose $\frac{3}{16}$ " thru 1"

Thermoplastic Hose $\frac{3}{16}$ " thru 1"

Air Conditioning Hose $\frac{5}{16}$ " thru $\frac{5}{8}$ "

1-Wire Braid Hose $\frac{3}{16}$ " thru 1"

2-Wire Braid Hose $\frac{1}{4}$ " thru 1"

4-Spiral Hose $\frac{3}{8}$ " thru 1"

6-Spiral Hose $\frac{1}{2}$ " thru 1"

XT356

REUSABLE COUPLING PRESS - SPIRAL HOSE

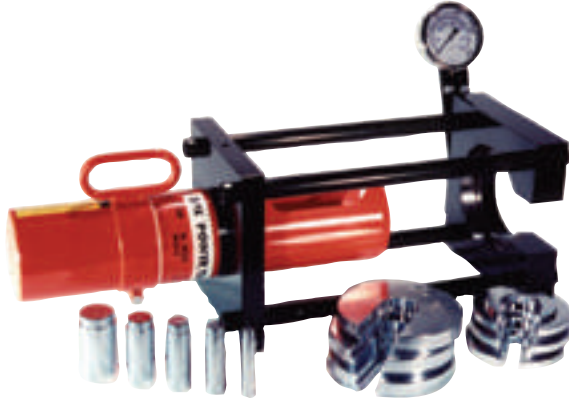

The XT356 includes:

- Press
- 1 H.P. electric pump
- Tooling to assemble the following:
 - 100R12 3/8" thru 2"
 - 100R13 3/4" thru 1 1/2" (2" available)
 - 100R15 1" thru 1 1/2" (2" available)

Features:

- 1 H.P. electric pump
- 7,500 PSI working pressure
- 55 ton cylinder
- Press is portable or bench mount

SAWS



Model #24397 -

- Capacity:** Cuts single and double wire braid hose to 2" I.D. Scalloped blade.
- Motor:** 1.5 horsepower 1/60/115V
- Dimensions:** 13" W x 24" L x 17" H
- Weight:** 65 Lbs.

Model #26253 -

- Capacity:** Cuts single and double wire braid hose to 2" I.D. Scalloped blade.
- Motor:** 2 horsepower 1/60/230V
- Dimensions:** 13" W x 24" L x 17" H
- Weight:** 65 Lbs.



Model #24392 -

- Capacity:** Cuts up to 2" I.D. single & multi-wire braid and 4 or 6 spiral hose. Scalloped blade.
- Motor:** 2 horsepower 1/60/230V. Available in 3-phase.
- Dimensions:** 22" W x 42" L x 24" H
- Weight:** 200 Lbs.
- Optional Equipment:** Coolant spray system for reduced friction when cutting.

EQUIPMENT

HS150 HOSE SAW



Capacity: Cuts two wire hose to 2", four spiral hose to 1¼", six spiral hose to 1".

Motor: 1 horsepower 115VAC

Blade: 103187-10 10" serrated blade

Capacity: Cuts two wire hose to 2", four spiral hose to 1¼", six spiral hose to 1".

Motor: 3 horsepower 220V 1PH, 220V 3PH, 480V 3PH

Blade:
103187 12" Serrated Blade

Accessories: Cut cycle counter and hose feeder guide are included.

HS300 HOSE SAW



HS500 HOSE SAW



Capacity: Cuts two wire hose to 2", four spiral hose to 2", six spiral hose to 2".

Motor: 5 horsepower 220V 1PH, 220V 3PH, 480V 3PH

Blade:
103187 12" Serrated Blade

Accessories: Cut cycle counter and hose feeder guide are included.

****Mister Kit:** Available for HS300 and HS500 - Part #103073. Mister sprays a fine mist of oil on saw blade. Increases blade life and helps make smoother cuts.

****Hose Channel:** Available for HS300 and HS500 - Part #103073. This part is an adjustable hose channel.

SKIVE HEADS



VS SERIES COUPLINGS	
100R13 / 100R15	
1¼"	SHVS-20
1½"	SHVS-24
2"	SHVS-32
Skive Handle	SH100

KEY CHAIN TOOL

SKIVE KEYS - VS,N, and E SERIES HOSE



Part # - KEYCHAINTOOL
Includes all three key sets.

EQUIPMENT

INSERT-E "E" SERIES HOSE DEPTH INSERTION TOOL



Part # - INSERT-E

INSERT-N "N" SERIES HOSE DEPTH INSERTION TOOL



Part # - INSERT-N

REEL LIFT



DIE RACKS

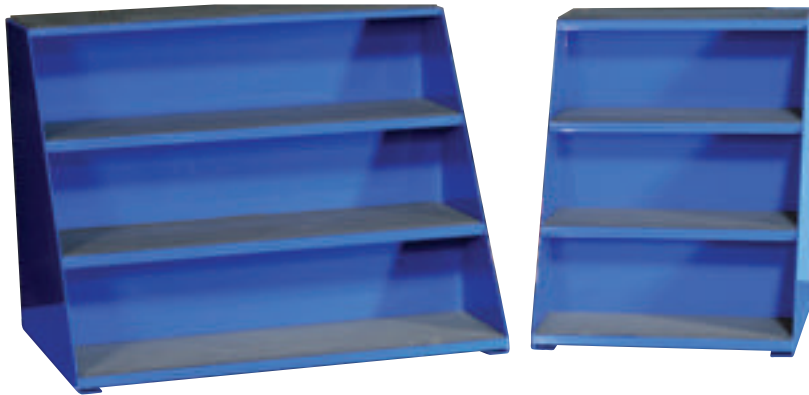

SH2000

Size: 20 $\frac{1}{2}$ " wide, 15 $\frac{1}{8}$ " deep, 16 $\frac{1}{8}$ " high

SH1000

Size: 12 $\frac{3}{8}$ " wide, 13" deep, 15 $\frac{1}{8}$ " high

FC40 CABINET

40 DRAWER FITTING CABINET



The **FC40** is designed for the following crimpers to mount on top:

FX17HD

FX17

FX21*

FX21FB

FXT400

*When mounting an FX21, order the 4" riser - Part # FX4RISE.

Size: 40" wide, 24" deep, 46 $\frac{1}{4}$ " high

INDEX

FLEXTRAL

FLEXTRAL

INDEX

Hose	Pg	Couplings	Pg	MML	C26	FL30	C47
J3	B2	Hose End Index	C2	FML	C27	FL45	C47
J4	B2			FML45	C27	FL60	C48
YK	B2	<i>E Series</i>		FML90	C28	FL67	C48
HJ	B3	MP	C5	MMS	C28	FL90	C49
ZX	B3	MPL	C5	FMS	C29	FL100	C50
ZXR	B3	MPX	C5	FMS45	C29	FL110	C50
TBR	B4	MPX90B	C6	FMS90	C30	FL120	C50
TBX	B4	FP	C6	MGAZ	C30	FL135	C50
FSH	B5	FPX	C6	FGAZ	C30	FLH	C51
LX	B5	MJ	C7	FL	C31	FLH22	C51
PROJET 3000	B6	FJ	C7	FL45	C31	FLH30	C51
PROJET 4000	B6	FJ45	C8	FL90	C31	FLH45	C52
ULTRAJET 4000	B6	FJ45	C9	MPWK	C32	FLH60	C52
SUPERJET 6000	B7	FJ90B	C10	FPWK	C32	FLH67	C52
607	B7	FJ90S	C10	FPWS	C32	FLH90	C53
707N	B8	FJ90M	C11	FPWW	C33	FLC	C53
617	B8	FJ90L	C12	HM	C33	FLC22	C54
618	B9	MF	C12	SP	C33	FLC30	C54
618W	B10	FF	C13			FLC45	C54
618N	B10	FF45	C13	<i>N Series</i>		FLC60	C55
618NW	B11	FF90S	C14	MP	C34	FLC67	C55
621	B11	FF90L	C14	MPA	C34	FLC90	C55
628	B12	MA	C15	MJ	C35	1901	C56
628N	B12	FA	C15	FJ	C35	1902	C56
625	B12	FA45	C15	FJ45	C36	1903	C56
627	B13	FA90	C15	FJ90B	C36		
907PW	B13	MOB	C16	FJ90S	C36	<i>V, VS Series</i>	
908BA	B13	MOBX	C16	FJ90M	C37	MP	C57
912	B14	MOBX90B	C16	FJ90L	C37	MJ	C57
915	B14	MIX	C17	MF	C37	FJ	C58
HX	B14	MIX45	C17	FF	C38	FJ45	C58
HH	B15	MIX90	C17	FF45	C38	FJ90S	C59
FX	B15	MRNS	C18	FF90S	C39	FJ90M	C59
FH	B16	FG	C18	FF90L	C39	FJ90L	C59
AXT	B16	FJIS	C18	MOB	C39	MF	C60
AXT-PS	B17	FJIS90	C18	FJIS	C40	FF	C60
AXT-HT	B18	FK	C19	FK	C40	FF45	C61
EX	B18	FK45	C19	FLK	C40	FF90S	C61
GX	B19	FK90	C19	FLK45	C41	FF90L	C61
PX250	B20	FLK	C20	FLK90	C41	MOB	C61
PX250-PS	B21	FLK45	C20	MKBC	C41	FJIS	C62
PX300	B22	FLK90	C20	MBSPT	C41	FK	C62
NT300	B22	MBSPT	C21	MBSPP	C42	FLK	C62
NZ	B23	MBSPP	C21	FBSPP	C42	FLK45	C63
VT300	B23	FBSPP	C22	FBSPP45	C42	FLK90	C63
VZ	B24	FBSPP45	C22	FBSPP90	C43	MKBC	C63
SX	B24	FBSPP90	C23	MML	C43	MBSPT	C63
QX	B25	FBSPP90B	C23	FML	C43	MBSPP	C64
CX	B25	FBSPPF	C23	FML45	C44	FBSPP	C64
QC	B26	BJBSP	C24	FML90	C44	FBSPP45	C64
VC	B26	BJBSPBT	C24	MMS	C44	FBSPP90	C65
CC	B27	SPML	C24	FMS	C45	MMS	C65
	B27	SPML45	C25	FMS45	C45	FMS	C65
		SPML90	C25	FMS90	C46	FMS45	C66
		BJM	C26	FL	C46	FMS90	C66
		BJMBT	C26	FL22	C47	FL	C67



INDEX

INDEX

FL22	C67	F Series	FBSPP	C105	J Series	
FL30	C67	MP	C85 FBSPP45	C106	MP	C126
FL45	C68	MJ	C85 FBSPP90	C106	MP90	C126
FL60	C68	FJ	C85 FML	C107	MPX	C126
FL67	C68	FJ45	C86 SP	C107	FP	C127
FL90	C69	FJ90S	C86		FPXT	C127
FL100	C70	FJ90M	C86 AF Series	Pg	FJ	C127
FL110	C70	FJ90L	C86 MP	C108	MA	C128
LET	C70	FF90S	C87 MPX	C108	MJ	C128
LET45	C70	MA	C87 FP	C109	FA	C128
LET90	C71	FA	C87 FPX	C109	MIX	C128
FLH	C71	FA45	C87 MJ	C109	FIX	C129
FLH22	C71	FA90	C87 FJ	C110	FML	C129
FLH30	C72		FJ45	C111	FML45	C129
FLH45	C72	P Series	FJ90S	C111	FML90	C130
FLH60	C72	MP	C88 FJ90M	C112	HM	C130
FLH67	C73	MPX	C88 FJ90L	C112	SP	C130
FLH90	C73	FP	C89 MF	C113		
FLC	C74	FPX	C89 FF	C113	1R Series	
FLC22	C74	MJ	C89 FF45	C114	MP	C131
FLC30	C74	FJ45	C90 FF90S	C114	FJ	C131
FLC45	C75	FJ90M	C90 FF90L	C115		
FLC60	C75	FJ90L	C91 FJIS	C115	2R Series	
FLC67	C75	MF	C91 FBSPP	C116	MP	C132
FLC90	C76	FF	C91 FBSPP45	C116	FJ	C132
FLOKA	C76	FF90M	C92 FBSPP90	C117		
FLOKA22	C76	MOB	C92 FML	C117	5R Series	
FLOKA45	C77				MP	C133
FLOKA90	C77	T Series	TS Series		MJ	C133
OKBR	C77	MP	C93 MP	C118	FJ	C133
1901	C78	MPX	C93 FJ	C118	FJ45	C134
1902	C78	FP	C94		FJ90	C134
1903	C78	FPX	C94 Z / ZR Series		FJ90L	C134
		MJ	C94 MA	C119	MA	C135
C Series		FJ	C95 FA	C119	FA	C135
Ferrule	C79	FJ45	C95 FA45	C119	MIX	C135
FLH	C79	FJ90B	C96 FA90	C120		
FLH45	C79	FJ90S	C96 MRNS	C120	Adapters	Pg
FLH90	C79	FJ90M	C97 BTF	C120		
FLC	C80	FJ90L	C97 BTF-P	C121	Quick Reference	D2
FLC45	C80	MF	C98 BTF45	C121	0304	D10
FLC90	C80	FF	C98 BTF45-P	C121	0304C	D10
FLOKA	C81	FF45	C99 BTF90	C122	0306	D10
FLOKA22	C81	FF90S	C99 BTF90-P	C122	0318	D11
FLOKA45	C81	FF90L	C100 BTM	C122	0319	D11
FLOKA90	C82	MA	C100 BTM45	C123	0403	D11
OKBR	C82	FA	C101 BTM90	C123	0404	D12
		FA45	C101 BTM90-P	C123	1404	D12
HA Series		FA90	C101 IOM	C124	1405	D13
FL	C83	MOB	C102 IOM90	C124	1501	D13
FL22	C83	MIX	C102 HM	C124	1501L	D14
FL30	C83	MIX45	C102 HM-P	C125	1502	D14
FL45	C84	MIX90	C103 BS	C125	1503	D15
FL60	C84	MRNS	C103 ACF	C125	1504	D15
FL90	C84	FJIS	C104 ACO	C125	1601	D16
		MBSPT	C104		1602	D16
		MBSPP	C105		1603	D16

INDEX

1700	D17	5406	D43	7002	D67	FS6400	D86
1703	D17	5406C	D43	7004	D68	FS6402	D87
1703FG	D18	5406P	D43	7005	D68	FS6403	D87
1704	D18	5406HP	D44	7005L	D68	FS6500	D87
1704FG	D18	5406SHP	D44	7005S	D69	FS6502	D87
1724	D19	5500	D44	7009	D69	FS6504	D88
1800	D19	5501	D45	7022	D69	FS6600	D88
1803	D19	5502	D45	7032	D70	FS6602	D88
1803FG	D19	5503	D45	7062	D70	FS6801	D89
1804	D20	5504	D46	7102	D71	FS6801L	D89
1804FG	D20	5505	D46	7202	D71	FS6802	D90
1824	D20	5600	D46	7204	D71	FS6803	D90
1901	D21	5601	D46	7205	D71	FS6804	D91
1902	D21	5602	D47	7222	D72	FS6809	D91
1903	D21	5603	D47	7588P	D72	FS7205	D91
1927-61	D21	5604	D47	7599P	D72	FS7210	D92
2403	D22	5605	D47	7688C	D72	FS7215	D92
2403LH	D22	5652	D48	8800	D72	FS7300	D92
2404	D23	6400	D48	9020	D73	FS7640	D93
2404L	D24	6400L	D49	9022	D73	C0304	D94
2404LL	D24	6401	D50	9023	D74	C0306	D94
2405	D25	6402	D50	9024	D74	C0318	D94
2406	D26	6404	D50	9087	D74	C0319	D95
2408	D27	6405	D51	9090	D74	C2403	D95
2500	D27	6408	D52	9124	D75	C2403LH	D95
2501	D28	6408H	D52	9224L	D75	C2404	D96
2501L	D29	6410	D53	9245	D75	C2405	D96
2501LL	D29	6464	D54	9247	D75	C2406	D97
2501LLL	D30	6500	D54	9322	D75	C2408	D97
2502	D30	6501	D55	9344	D76	C2500	D97
2503	D31	6502	D55	9522P	D76	C2501	D98
2504	D31	6504	D55	9610	D76	C2502	D98
2505	D32	6505	D56	9611	D76	C2503	D99
2601	D32	6506	D56	9620	D77	C2601	D99
2602	D33	6565	D56	9621	D77	C2602	D99
2603	D33	6600	D57	9644C	D77	C2603	D99
2605	D34	6602	D57	9722LN	D77	C2605	D100
2606	D34	6603	D57	9900	D78	C2606	D100
2609	D34	6606	D58	FS0304	D79	C2650	D100
2613	D35	6701	D58	FS0306	D79	C2700	D101
2650	D35	6701L	D58	FS0318	D79	C6400	D101
2700LN	D35	6801	D59	FS0319	D79	C6400L	D101
2701LN	D36	6801L	D60	FS0403	D80	C6801	D102
2702LN	D36	6801LL	D60	FS2403	D80	C6802	D102
2703LN	D36	6801LLL	D61	FS2404	D81	C6803	D102
2704LN	D37	6802	D61	FS2406	D81	C6804	D102
2705LN	D37	6803	D62	FS2408	D82		
2706LN	D37	6804	D62	FS2500	D82	Accessories	Pg
3474	D38	6805	D63	FS2501	D82		
4404	D38	6805L	D63	FS2503	D83	Nylon Sleeving	E2
4501	D39	6806	D63	FS2601	D83	Polyurethane Sleeving	E2
4503	D39	6807	D64	FS2603	D83	Plastic Wrap MD	E3
4601	D40	6809	D64	FS2650	D84	Pre-Cut Package	E3
4603	D40	6815	D64	FS2700LN	D84	Plastic Wrap HD	E3
4604	D41	6900	D65	FS2701LN	D84	Spring Guard	E4
5000	D41	6901	D66	FS2702LN	D85	Fire Sleeving	E4
5404	D42	6902	D66	FS2703LN	D85	Strain Reliever	E4
5405	D42	7000	D67	FS2704LN	D85	Flat Armor Guard	E5



INDEX

INDEX

O-Ring Kits	E6
Cap & Plug Kits	E6
Metric Thread ID Kits	E6
Boss O-Rings	E7
Face Seal O-Rings	E7
SAE Flange O-Rings	E7
Caterpillar Flange D-Rings	E7
StopFlex Nipple Retention	E8
StopFlex Hose Bands	E9
Hose Handle Clamps	E10
Camlock Velcro Straps	E10

Equipment Pg

FX17E	F2
FX17A/17H	F2
FX17LWP	F3
FX21FBE FATBOY	F4
FX21FBA/FBH	F4
FX21	F5
FX21E	F6
FX41 THE BOSS	F7
FX200	F8
FX300	F9
FX400	F10
FX1200	F11
FXT-400	F12
FXT-420	F12
FXT-480	F12
XT356	F13
Saws	F13
HS150 Hose Saw	F14
HS300 Hose Saw	F14
HS500 Hose Saw	F14
Skive Heads	F15
Key Chain Tool	F15
Insert-E	F16
Insert-N	F16
Reel Lift	F16
Die Racks	F17
FC40 Cabinet	F17



www.FLEXTRAL.com