

A man with short dark hair and a light beard, wearing a blue polo shirt, stands with his arms crossed against a background of dark, horizontal metal slats. The text 'THE MODERN TECH' is overlaid on the right side of the image.

# THE MODERN TECH

ISSUE #01

## **CUSTOM TRUCK BUILD WITH BRYAN FULLER**

Pg 34

## **FIX CARS FASTER**

See how OTC's diagnostics lineup goes uncontested with fastest code-to-fix, best-in-class coverage and more.

Pg 6

## **TOOL TALK**

Eric the Car Guy, Eric Obrochta and Jim the Car Guy weigh in on Specialty Tools, Encore and Pullers.

Pgs 12, 13, 30

## **WIRE SERVICE TOOLS INVENTOR MIKE KAWELL**

Pg 8

## **HEAVY-DUTY SUSPENSION BUSHING TOOL KITS**

Pg 31



# FIND THE RIGHT TOOLS, USE THEM FOR LIFE.

## WHAT WE LIKE MOST ABOUT TECHNICIANS IS THEIR WORK ETHIC.

Technicians are problem solvers who aren't afraid of sweat on their brow and grease on their hands. They provide high quality services that demand high quality tools. When they need a reliable tool, they know they can depend on OTC tools to deliver.



Owatonna Tool Company for the long haul — proudly designing and manufacturing American specialty service tools, diagnostics and shop equipment since 1925.

**OTC TOOLS ARE SOLD THROUGH DISTRIBUTORS, RESELLERS  
AND RETAILERS. LEARN MORE AT [OTCTOOLS.COM](http://OTCTOOLS.COM).**

# LOOKING FOR AN OTC PRODUCT?

OTC tools and equipment are sold through distribution partners, resellers and at retailers. Visit [OTCtools.com](http://OTCtools.com) to learn more.

## DISTRIBUTORS



## RETAIL



## MOBILE DISTRIBUTORS



## HEAVY DUTY DISTRIBUTORS



# THAT'S HIM, HE FIXED MY CAR

POWERED  
BY BOSCH

FASTEST  
TO THE FIX

ON-TOOL  
& ONLINE REPAIR  
INFORMATION

EASY  
TO USE

VEHICLE  
COVERAGE



## FIX CARS FASTER THAN THE USUAL SUSPECTS

The OTC Encore diagnostic system with Identifix® works fastest from code-to-fix, has best-in-class coverage, is easy to use and is the ultimate repair suite.

**Learn more, request a demo or enter to win an Encore every week through December 31, 2016 at [otctools.com/fix-cars-faster](http://otctools.com/fix-cars-faster).**



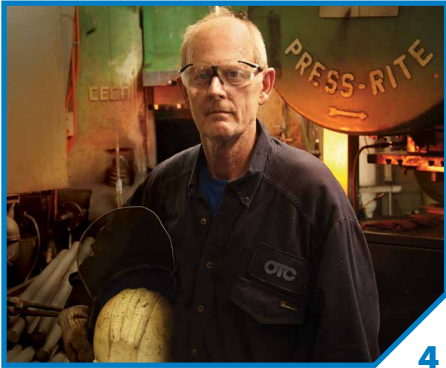

4



8

**CUSTOMER SERVICE**

Phone: 800-533-6127  
 Fax: 800-283-8665  
 Email: inquiry@service-solutions.com

**REPAIRS**

Service Repair  
 Phone: 800-344-4013  
 Fax: 507-455-4318  
 eservice@service-solutions.com

**TECHNICAL SUPPORT**

Phone: 800-533-6127  
 Fax: 800-955-8329  
 Email: tech@otctools.com

**INTERNATIONAL SALES**

Phone: 507-455-7223  
 Fax: 507-455-7063  
 Email: intl.inquiries@service-solutions.com

**MAILING ADDRESS**

Bosch Automotive Service Solutions  
 28635 Mound Road  
 Warren, MI 48092 USA

**PUBLISHER:** Alison Accavitti

**EDITOR / MEDIA INQUIRIES:**  
 Justin Fisette

**DESIGN TEAM:** Cameron Payne,  
 Kimi Blackledge, Milt Taylor

**THANK YOU TO:** Steve Cross, the product management and field technical sales teams; and the forged bottle opener team - Todd Derby, Cory Pleschcourt, Jim Gwilt, Dedra Thraenert, Brent Underwood and Duane Klecker

**FROM THE FORGE 4**

OTC's head hammer explains why he loves forging steel into your favorite tools

**ALL IN THE FAMILY 6-7**

OTC diagnostics for every age, stage, budget and experience

**HOW'D THEY DO THAT? 8**

A look into the OTC inventor program

**EMISSIONS JUST GOT MORE COMPLICATED 10-11**

The impact of MODE 10 on your next EVAP job

**SOUTH MAIN AUTO ON OTC 12**

Eric O. with his take on the Encore

**FIRST TIME, EVERY TIME 13**

Jim the Car Guy shares his love of OTC Tools

**TOOL JUNKIE 15-33**

The best, brightest and newest from OTC

**STAY DIRTY 30**

Eric the Car Guy talks training, teaching and tools

**NEVER ENOUGH TIME 31**

One of many OTC tools that will help you get some time back

**CUSTOM OTC BUILDS 34-35**

Master fabricator Bryan Fuller shares his excitement for building a custom OTC trike and truck

**GET YOU SOME 37**

Looking for OTC Tools? Find a distributor near you

**ROOTED IN AMERICA 38-39**

Take a look back at the 90-year history of one of America's most celebrated tool brands

**EXPERTS IN YOUR AREA 40-43**

A nationwide team of technical experts for you

**WARRANTY, SUPPORT AND SERVICE 46**

# A PROUD HERITAGE

38-39



WELCOME

# FROM THE FORGE

## MY LIFE'S WORK AS OTC'S HEAD HAMMER

By Steve Cross, Drop Forge Hammer Operator

Thirty-nine years ago, I hired on at Owatonna Tool Company as a janitor, a role that was never meant to last. I quickly moved into material handling, then I got shoved in the weld shop, then I got hammers in the forge department, and here I've stayed. I wasn't sure if it was for me at first, but it was something that looked challenging. Some people just don't want to be that physical, but I don't mind it.

The forge is where OTC makes specialty tools. It's not an easy job. You throw the steel in, wait until it gets up to temperature, get everything running, heat the dies, then hammer products out. There's a lot of heavy lifting, twisting, turning, a lot of heat and a lot of noise. We go through an average of 1,000 pounds of steel every day depending on the size of the job. On a typical day, you come in, punch in, get everything ready, check your equipment over, load up the furnace and get steel in it, then start running. Then you do that all day long.

I'm proud of the products we make – pullers, c-frames, u-joints, hub grapplers to name a few. It's tough to say what my favorite product to make is. I like to make a job where you have to roll and block a part and finish it out, not just beat it. We make anything that is made out of solid steel, hand tools, hard tools, all that stuff. Making tools in the fire is the best way. Our tools are high quality, because if you don't make quality then you don't last. There's a lot of competition out there and we can beat 'em. Our craftsmanship is what puts us ahead in the game. All of these tools are made by guys that have used them, and they work. You're not going to buy something that doesn't work. If it doesn't finish the job, you're not going to buy another one.

*"I'M ALSO PROUD OF THE OTC BRAND. I'M MAKING A BRAND THAT'S BEEN AROUND A LONG TIME. ANY GUY THAT'S WORKED ON A CAR HAS HEARD OF THE OTC BRAND, AND THEY PROBABLY HAVE USED IT."*

We're a USA company that's been here for many years. I think that's what makes the brand. When I picture the OTC brand in my mind, I see a single jaw puller that we've been making for years. Just a plain jaw puller that's been around for a long time. If you've ever used one, it works. It's reliable and easy to use. That's how I describe the brand.

I've had other jobs here, and there's nothing else I really care to do. Most people would say they don't want to touch the forge. Only a handful of people would maybe like the money, but they stay away from the forge because of the rugged physical strain you're put through. There are days when it's 100 degrees in Minnesota and you're working in 140 degrees all day.

My motto is to always do the best I can. If tools go out right, and they look good, then I did my job right.

# FASTER ONE-MAN BRAKE SERVICE

## 6596 BRAKE PAD GAUGE

Check brake pad life without removing wheels. Green-yellow-red indicator clearly shows pad life.



## 7302 BRAKE CALIPER PIN/BOLT REMOVER

Quickly remove stuck caliper pins and bolts with this 90° pickle-fork style tool. Two tools, one for use with an air hammer and the other with a striking cap, drive pins and bolts inward toward the vehicle.



## 6980 BRAKE DRUM/ROTOR PULLER

Stuck drums or rotors slow the job down. Use the right puller to help remove and replace worn rotors or drums with up to 7 tons of force\*.



## 6720 FLARE NUT LOCKING PLIERS

Rusted or rounded flare nuts waste your time and patience. Grip all 6 sides of a flare nut with these locking jaw pliers to turn and remove damaged flare nuts.



## 6703 LINE FLUID STOPPER KIT

Eliminate fluid leaks and prevent moisture from entering brake fluid when replacing lines. Includes two banjo stoppers, two steel line stoppers, six plugs, a line disconnect tool and a long-reach pinch tool.



## 8104A-SET BRAKE BLEEDER WITH AUTO FILLER SET

Bleed brake lines and automatically refill the fluid reservoir without any help. Using shop air, create a controlled vacuum to bleed brake lines and refill the system.



# DIAGNOSTICS EVOLUTION

OTC scan tools, powered by Bosch, are the fastest from code-to-fix with more than 30 years of OE-level coverage. The easy-to-use tools are favored among technicians who want coverage and repair information on the tool for vehicles they see in the shop everyday.



## TRIAGE TOOL

### 3210 CodeConnect with ABS & Airbag

OBD II coverage and likely fixes for most 1996 and newer cars and light trucks.

- Color screen
- EPB Caliper Retract for most Audi/VW vehicles
- Brake Bleed test for Ford, GM, Chrysler & Toyota vehicles
- Steering Angle Reset for GM and Nissan vehicles
- CodeConnect® database on-tool with 26+ million most likely fixes based on DTC and vehicle
- Read and erase most Domestic, Asian and European(NEW!) ABS & SRS/Airbag trouble codes, 1996-2013
- ABS & Engine Enhanced Live Datastream for GM, Ford and Toyota
- Transmission Enhanced Live Datastream for GM and Ford
- Oil Light Reset
- Battery life reset
- Dual PID graphing



## FIX CARS FASTER

### 3893 Encore

The OTC Encore diagnostic system with Identifix® is fastest at what counts, and that's fixing vehicles. No tool is faster from code to fix, pulling the DTC and showing the likely repair.

- Fastest from code-to-fix
- Best-in-class vehicle coverage
- 7" screen
- Powerful, fast Android OS
- Easy to use
- Ultimate online and on-tool repair suite
- Powered by Bosch
- Optional 3834 TPR kit with Bluetooth wireless TPMS performs sensor ID transfer
- Optional HD Standard 3895-07 kit includes Class 4 – 8 vehicle coverage
- Key and remote reprogramming procedures for vehicle and transmitters for remote controlled alarm, central locking and immobilizer systems
- Battery disconnect procedures for vehicles that have had battery service, replacement or loss of electrical power





## COMING SOON: ELITE DIAGNOSTICS

### 3896 Evolve

As modern vehicles become increasingly complex, OTC diagnostics, powered by Bosch, continues to evolve. The flagship tool includes a wireless VCI, J2534-compliant device, larger screen and full-system wiring diagrams.

- 10.4" high-resolution screen reduces glare
- Powerful, fast Android OS
- Dual WiFi architecture provides a secure, wireless VCI connection and reliable Internet connection. Move freely around the vehicle and shop with confidence.
- Includes full system wiring diagrams, not offered on any other scan tool in the market
- Includes tablet docking station and backpack for increased battery life, performance and safe storage
- Includes J2534 compatible device for reprogramming and reflash.

## CODE-TO-FIX WITH IDENTIFIX

OTC diagnostics is built around repair information, with more than 26 million fixes on-tool from Identifix, access to top repair networks and sources. OTC tools have exclusive access to Identifix on-tool within the diagnostic session without having to re-enter vehicle information.

*Not an Identifix subscriber? Purchase an Encore or Evolve and receive free access to the most complete repair information and Identifix ASE Master Technicians for 60 days.*

MEET THE INNOVATOR

# THE OTC CRIMPWELL

**MIKE KAWELL**  
OWNER/MANAGER  
OF MIKE'S GARAGE  
(FARIBAULT, MN)

[MIKESGARAGE411.COM](http://MIKESGARAGE411.COM)



**AS AN EXPERIENCED MECHANIC TURNED SHOP OWNER/MANAGER,** Mike Kawell of Mike's Garage in Faribault, MN has seen it all when it comes to automotive repairs. From a cut and dry oil change to a tinkering noise coming from "somewhere" on the vehicle, it's the unscripted repair endeavors that can either be the most frustrating or rewarding – it depends on your approach! Kawell looks at these challenges as an opportunity and as a result can add the title 'inventor' to his already robust industry resume.

In 2010, Kawell had been working on a vehicle that had had its stereo removed, resulting in a cut lateral harness that created a nearly impossible angle to reconnect the radio wiring to the little stubs that were left. The 90 degree needle-nose pliers were just too flexible to actually crimp wire connectors. He needed something maneuverable, but firm. The solution was a side cutter and a little welding magic for the facades. Applying his persistence and creative problem-solving, Kawell shared his discovery through the 'Invent with OTC' program and thus, the OTC 5912 Crimpwell Angled Wire Crimper was born.

Kawell and the OTC engineers worked closely through the development process, sharing notes and collaborating along the way. Kawell's design of the OTC 5912 crimpers makes crimping connectors easier than ever - and is especially valuable where wire service is compromised by limited access. The final product came from Kawell's understanding that if he was bending, modifying and tinkering, then other technicians were most likely looking for the same solution as well. **Necessity is the mother of invention!**



*Have a solution to a common service problem? This is your opportunity to showcase your innovative tool creations, so show us something we haven't seen before. Submit your tool idea to OTC today. It could be the next must-have in the OTC Tool lineup and we'll review to potentially prototype, manufacture, and sell it. If your tool is selected, you will receive a competitive royalty on every tool sold.*



**INVENT  
WITH OTC**  
[OTCTOOLS.COM](http://OTCTOOLS.COM)

# VITAL SERVICE TOOLS

## 6980 BRAKE DRUM & ROTOR PULLER

- Remove and replace worn rotors or drums faster
- Pull with up to 7 tons of force\*
- Spread to 12-3/4" and 5" of reach



## 5942 XZN BIT SET

- For use in Audi and VW door hardware
- Sizes 4, 5, 6 and 8 with 1/4" internal drive and 7/16" external hex drive
- Sizes 10, 12, 14 and 16 with 3/8" internal drive and 5/8" external hex drive



## 4579 9-WAY SLIDE HAMMER SET

- Quickly pulls bearings, gears and seals
- Internal and external jaws work on multiple pulling jobs
- Included wrench adapter and cross blocks help pull more components



## 6575 HUB GRAPPLER KIT

- Removes wheel hubs and bearings on vehicle
- Easier to use, faster and more applications than the Hub Tamer
- Larger, stronger forcing screw and proprietary heat-treated steel extends tool life



## 8330 RESURFACING GRINDER

- Resurface and clean wheel centers or studless rotors
- Reduce lateral runout and ensure solid tire-rotor-hub connections
- Removes corrosion on most flat surfaces. 1,500 RPM max



## 4295 WHEEL STUD SERVICE KIT

- Works on most hubs, all stud sizes with fewer adapters
- Use on-vehicle with impact wrench for faster service
- Reduces damage to hubs, studs and bearings



\*See [OTCTools.com/puller-safety](http://OTCTools.com/puller-safety) for puller safety information.

# EVAP SYSTEM TESTING ON LATE-MODEL VEHICLES

## THE IMPACT OF MODE 10 ON YOUR EMISSIONS DIAGNOSTIC TESTING

MANY LATE-MODEL VEHICLES USE A NATURAL VACUUM LEAK DETECTION SYSTEM TO ALERT DRIVERS OF EMISSIONS PROBLEMS. Using your scan tool, you can diagnose those issues by reading codes and testing the various components within the EVAP system. These include the vent solenoid and purge valve.

After you plug in your scan tool and pull codes, perform an all-systems scan to look for freeze frame data. This information will show you what happened when the code was set, allowing you to repeat those conditions and isolate the issue.

The next step is using maintenance or special tests specifically for the EVAP system. In here you'll be able to test the vent-purge solenoid and purge valve to check the impact it has on fuel tank pressure. As you increase the purge, fuel tank pressure should drop. If you decrease purge, fuel tank pressure will rise as vapors are not being allowed to vent.

If increasing or decreasing purge does not change fuel tank pressure, you may have a failed solenoid that is not opening or closing the purge valve.

If the EVAP purge test fails, grab a voltmeter and go under the hood. From there you'll test voltage at the connector for the purge solenoid. Using your scan tool, increase purge percentage. If voltage changes, you've confirmed the wiring is good and the purge solenoid needs to be replaced.

Once you've identified the problem and replaced the failed part, run your tests again to confirm the fix. Go back into your EVAP special tests and increase purge. As you purge vapors from the fuel tank, pressure will drop, confirming your solenoid is operating properly. You're now pulling engine vacuum into the fuel system, allowing fuel tank pressure to be released.

After fixing the vehicle you may be tempted to clear the codes, but you might not be able to. Mode 10 requires newer vehicles to self-validate EVAP issues, requiring a specific number of drive cycles to self-test and clear the codes.

### MODE 10 REQUIRES NEWER VEHICLES TO SELF-VALIDATE EVAP ISSUES

So if you're fixing a vehicle with an EVAP issue, remember to run all your EVAP / emissions special tests, do an all systems check to view freeze frame data and that Mode 10 may not let you clear codes. If the repair has been completely successful the scan tool may allow you to turn off the check engine light, but a emission code may still be present in Mode 10 (\$0A) when reading DTCs, until the computer has ran its own internal system test validating the repair was successful.

To help in your next EVAP diagnosis, remember there are three main criteria for when a vehicle will perform its tests and turn off a DTC light.

#### THOSE CRITERIA ARE:

- The PCM turns off the malfunction indicator lamp (MIL) after three consecutive ignition cycles that the diagnostic runs and does not fail
- A last test failed, or current DTC, clears when the diagnostic runs and does not fail
- Mode 10 DTC clears after 40 consecutive warm-up cycles if no failures are reported by this or any other emission-related diagnostic

SEE THE ENCORE EVAP EMISSIONS TESTING IN ACTION





THE SOUTH MAIN AUTO  
YouTube CHANNEL



**ERIC OBROCHTA**  
SOUTH MAIN AUTO REPAIR  
AVOCA, NEW YORK



**" THE OTC ENCORE IS INTUITIVE AND EASY TO USE, SO I COULD SEE THIS TOOL BEING A STAPLE IN GARAGES AND SHOPS"**



# TOOL TALK WITH ERIC OBROCHTA ON THE OTC ENCORE

**AKA South Main Auto Repair on YouTube**

I'm Eric of the YouTube channel South Main Auto Repair, named after the three bay shop in upstate New York that I own and operate. I produce videos to record the automotive repairs that come in the shop day-to-day, providing accurate information to save consumers time and money. Through my YouTube channel, I have the ability to share my love for fixing cars along with my knowledge and experiences. The automotive industry is my passion; I grew up in my parents' shop helping out where I could and learning the basics. For over 17 years, I have worked full time as a mechanic with experience repairing domestic and Asian cars as well as light trucks.

At South Main Auto Repair, we see more diagnostic work than anything else. When given the opportunity to test out the OTC Encore, I was excited to give it a try. People ask me why I switch scan tools in my videos, and the answer is that some tools are just more capable than others. So far I've had the chance to play with it a bit, and have had it plugged into about 5 different cars already. Whether it's been used to assess a lean code and a misfire on a 2007 Mazda B-Series Pickup B3000 or no power locks and no power windows in a 2008 Chrysler Town and Country, the Encore works quite well. There are many functionalities with the Encore and though it's still pretty new to me, so far I've been super impressed with this tool and it's been phenomenal to have in the shop. The OTC Encore is intuitive and easy to use, so I could see this tool being a staple in garages and shops.

After featuring the OTC Encore in my repairs, I have received plenty of inquiries from viewers about the tool. We're continuing to test out the OTC Encore, so be sure to check out my channel to see it in action in upcoming videos!

Search for South Main Auto Repair on YouTube for repair videos, tool reviews and more from Eric O.



# TOOL TALK WITH JIM MAROTTA

## AKA JimtheCarGuy on YouTube

Jim Marotta is a technician with more years of experience under the hood than many others in the profession have even been alive. For more than 40 years, Jim has been identifying, diagnosing and fixing whatever problems are presented to him at his shop, J&S Auto Repair in Bayonne, NJ.

Jim truly believes that the right tools are part of the equation. "To do this job well, you need to be honest, knowledgeable and have the right tools to get the job done. I've been doing this for so long and my reputation is what keeps people coming back. I've seen children of my oldest customers grow up to now have children of their own. Some of my customers have been coming back to me through three generations."

**"I'VE HAD ALL SORTS OF OTC TOOLS FROM HUB GRAPPLERS TO PULLERS, AND THROUGHOUT IT ALL, THEY PERFORM EXACTLY AS NEEDED AND ALWAYS GET THE JOB DONE BETTER THAN ANYTHING ELSE ON THE MARKET."**

Throughout his career, Jim has seen the profession change drastically. The most significant advancement is the inclusion of on-board diagnostics (OBD) and the new set of skills required of technicians to decipher and repair modern-day issues.

Despite the changes related to the vehicles he services, the one thing that has not changed in his shop is his use of OTC tools. In fact, he can even recall the first time his tool guy walked into his own shop and sold him an OTC Valve Spring Compressor. Jim still has that same tool and despite its obvious wear and tear, still uses it to this day on some of the classic cars that regularly come in for service.



**JIM MAROTTA**  
J&S AUTO REPAIR  
BAYONNE, NJ



Jim's channel, JimTheCarGuy features videos explaining how to accurately diagnose and repair today's complicated cars and trucks that come through his shop, J&S Auto Repair. He has more than 40 years in the business and has seen just about everything. Relying on his experience and ingenuity, he thoroughly walks through many problems that other technicians experience and keeps up with it all just because he likes helping others do good, quality work.



## WE CHATTED WITH JIM RECENTLY ON OTC, HIS SHOP AND HOW THE WORK HAS CHANGED.

### *How have OTC tools worked for you over the years?*

JM: Throughout the years, I've learned that if you want a tool that lasts, you need to first see if OTC has that specific tool in its portfolio. I've had all sorts of OTC tools from hub grapplers to pullers, and throughout it all, they perform exactly as needed and always get the job done better than anything else on the market. In fact, a number of years ago, when GM started using snap ring fasteners on their fuel lines and transmissions, there was really nothing available in the aftermarket to easily get to them. I even tried to make my own tool to get the job done, but it still wasn't quite right. So after that didn't quite work, I made a few phone calls to colleagues I knew and trusted and was pointed in the direction of the OTC 6611 Transmission Line Disconnect. That specific tool is still used in my shop and I've recommended it to anyone that asks. It's the only thing that gets the job done without damaging anything else in the process.

### *Has their usefulness evolved over the years?*

JM: This profession has really evolved over the past years. Lighter metals, increased use of plastics and reduced space in the engine compartment has really made simple jobs from years past more difficult. You can't get by with just a few wrenches, screwdrivers and pliers. OTC has kept ahead of the needs of technicians and continues to provide specific solutions for the continuing advancements of vehicle technology.

### *What is the most common type of work you do at the shop?*

JM: It seems more and more that we are completing brake job after brake job at the shop and OTC tools are often used in that process. In fact, OTC 4503 Stinger Double Flaring Tool Kit is one product that is invaluable when I'm working on brake lines. It's the only tool I've seen, when used correctly, to ensure there is no leak in the brake line once the job is done. It's one of the stars of my videos. I've featured it in a handful of the various brake videos, regardless of manufacturer, on the site.



NEW GIANT ALLOY

adjustable

wrenches

REPLACE 29 SIZES

THINNER • LIGHTER

STRONGER



NOT THIS

THIS

Now for the first time quality, light-weight, alloy steel adjustable wrenches drop-forged to stand up under heavy duty jobs. The OTC Slim Twins make tough jobs easy -- save tool and time costs -- result in faster, more productive work in your shop or on emergency calls. The OTC Slim Twin Wrenches replace 29 standard size wrenches.

OA-24 is 24" long, 7/8" thick and weighs only 10 lbs. Adjusts to 13 standard sizes from 1-3/8" to 2-7/8". OA-36 is 35" long, 1-1/8" thick and weighs only 22 lbs. Adjusts to 16 standard sizes from 2-15/16" to 4-3/4".



EXCLUSIVE DESIGN GIVES ADDED STRENGTH IN PROPERLY LOCATED LEVERAGE POINTS FOR LONG SERVICE.

PATENT APPLIED FOR



OWATONNA TOOL COMPANY

373 CEDAR STREET  
OWATONNA, MINN.

A VINTAGE AD FROM THE 1940s. LEARN MORE ABOUT OTC'S PROUD HERITAGE ON PAGE'S 38 & 39.



**OTC ENCORE 3893**

The OTC Encore is the fastest-to-the-fix diagnostic tool with a powerful Android operating system, crisp touch screen display, comfortable rubber overmolded grips, 8GB internal storage and integrated Wi-Fi and Bluetooth. Encore owners will be automatically enrolled in our Diagnostics for Life program that provides a lifetime hardware warranty\*. Quarterly software updates add more vehicle coverage, tests and resets to help you access, diagnose and fix more vehicles faster.

*\*Terms and conditions apply*



# DIAGNOSTICS



**CAN TEST BOX 3415**

Connect, detect, monitor voltage and more. Use this tool for diagnosing electrical faults and CAN bus line activity. Check power and ground circuits, check active protocol lines or connect a multimeter or oscilloscope for detailed signal analysis. Connects between Diagnostic Link Connect (DLC). Verify ECU activity, monitor OBD II data lines, check monitor and battery voltage and more.

**AWARD WINNING**

**SMART BATTERY TESTER 3200**

Test faster with the first market solution to utilize the power of your smart device. Test battery, charging and starting systems in less than three minutes. Receive a comprehensive, full color report directly to your smart device for easy sharing with your customer. The internal 9V battery allows testing of deeply discharged batteries.

**PRODUCT SPOTLIGHTS**



**BEST SELLER**

**BATTERY & ELECTRICAL SYSTEM DIAGNOSTIC TESTER 3167**

Digital circuitry precisely controls battery test loads to accurately determine battery conditions. Tests both flooded lead acid and AGM/GEL cell batteries accurately—down to 1 volt state of charge. Tests vehicle starting and charging systems with minimal user interaction. Tests all 6- & 12-volt batteries with a 50-2000 CCA operating range.



**BEST SELLER**

**MINUTEMAN BATTERY TESTERS 3130AGM / 3131AGM**

MinuteMan Plus multi-application electrical system tester saves you hours when you're testing batteries, starters, alternators, regulators and charging systems. Works on all 12-volt automotive-type batteries with cold cranking amp ratings of 100-1500. This includes batteries found in motor-vehicle, marine, agricultural, forestry, and industrial applications. The tester operates from either 110 volts AC or its own internal, rechargeable 6-volt battery. Features self-calibration, an internal battery check, and an automatic shut-down to reduce power consumption.

**3131AGM**

Same as No. 3130AGM, but also includes roll-around cart with two additional shelves for other equipment.

**SOFTWARE UPDATES FOR GENISYS EVO®**



**2015 SOFTWARE LOYALTY KIT OTC-3421-153**

- Designed for customers who already have System 4.0 and newer.
- Includes 2015 Domestic/Asian and 2014 European



**2015 SUPER BUNDLE KIT OTC-3421-152**

- Everything needed to update a Genisys EVO
- Includes 2015 Domestic/Asian, 2014 European, and preloaded System 5.0 memory card

# KEEP YOUR TRUCKS RUNNING

## A CLEAN DPF SAVES MONEY AND REDUCES DOWNTIME

Cleaning diesel particulate filters can take as little as 40 minutes to restore filtration efficiency.

### Installing a DPF cleaner in your shop can:

- Reduce DPF replacement costs
- Reduce DPF cleaning costs
- Increase your fleet's efficiency
- Make your filters last longer

Visit [otctools.com](http://otctools.com) for more information on DPF cleaners and to keep your trucks on the road.

## PRODUCT SPOTLIGHTS



### SMART BATTERY CHARGER AND MAINTAINER 3176

The Smart Battery charger and Maintainer utilizes a patented 5-Stage Automatic charging system designed to charge a battery efficiently while prolonging the life of the battery. The automatic power switching gives you the ability to charge your battery to 100% without worrying about damaging the battery. The battery charger/maintainer comes with clamps for jump starts or overnight charging and ring connectors for permanent connection to seasonally used vehicles such as RVs and motorcycles.



### PROFESSIONAL MEMORY SAVER 3177A

An effective solution for saving vehicle data, the Professional Memory Saver saves the vehicles on board diagnostic memory and other on-board memory components such as anti-theft radios, digital clocks, radio presets, seats, mirrors, comfort settings, etc. when the vehicles battery is removed or disconnected. Includes OBD II cable for fast connection to the vehicle, cigarette lighter adapter for use with vehicles that do not have an OBD II connector LED lights confirm circuit between the cigarette lighter/power outlet and the vehicle's battery with the ignition on or off.

18 THE MODERN TECH

## BEST SELLER



### TRILINGUAL OBD II, ABS & AIRBAG SCAN TOOL 3209

Live data with color screen scan tool. Updated with 2013 model year coverage. Record and playback live data. Monitor battery, alternator and charging systems. AutoID upon plugging the tool in will automatically populate vehicle data for most 2000 and newer vehicles. Works with all 1996 and newer vehicles (OBD II, CAN, EOBD). View all modes OBD global data including oxygen sensors and Mode 6. Reads and displays ABS and airbag codes for most 1996 and newer GM, Ford, Chrysler, Toyota, Honda, Nissan and Hyundai vehicles. USB update cable included.

## INNOVATION

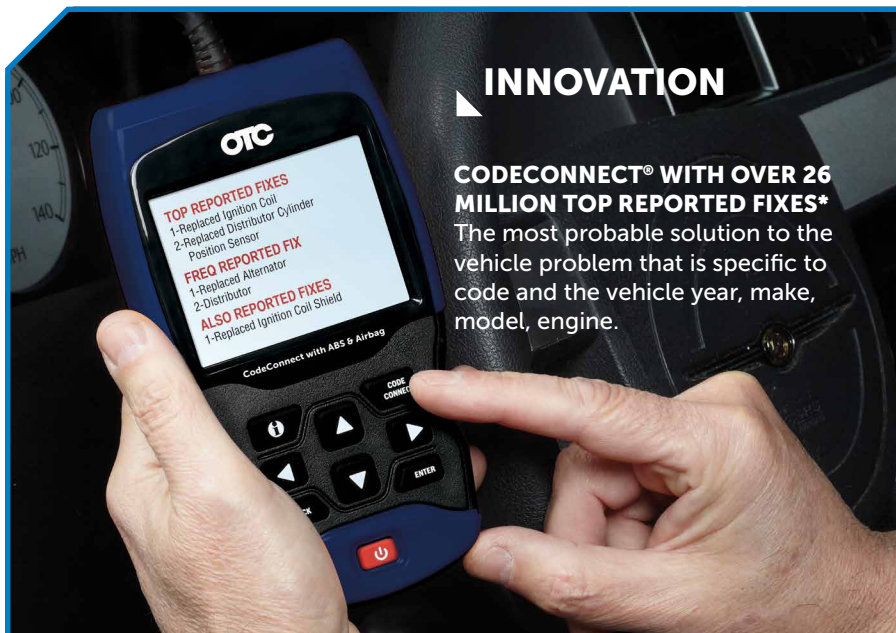

### CODECONNECT® WITH OVER 26 MILLION TOP REPORTED FIXES\*

The most probable solution to the vehicle problem that is specific to code and the vehicle year, make, model, engine.

### OBD II, CAN, ABS & AIRBAG 3210

Live data with color screen scan tool, now with brake service, steering service, oil and battery resets, including EPB caliper, steering angle and BMW brake pad sensor resets. Includes Codeconnect® with over 26 million top reported fixes\*, the most probable solution to the vehicle problem that is specific to code and the vehicle year, make, model, engine. Includes European ABS and manufacturer specific powertrain coverage. Updated 2013 model year coverage for manufacturer specific codes and through latest model year for global coverage. Monitor battery, alternator and charging systems. AutoID upon plugging will automatically populate vehicle data for most 2000 and newer vehicles. Works with all 1996 and newer vehicles (OBD II, CAN, EOBD). View all modes obd ii global data including oxygen sensors and mode 6. Reads and displays abs and airbag codes for most 1996 and newer GM, Ford, Chrysler, Honda, Hyundai, Nissan, Toyota, Audi, BMW, Jaguar, Land Rover, Mercedes Benz, Smart, Volkswagen, Volvo vehicles. Displays instant mpg, average mpg, elapsed time, distance (MI), fuel used (GAL) and average speed (mph) with the ability to alternate between English and metric units on screen.



**OBD II & ABS SCAN TOOL 3208**

Diagnose and fix problems on vehicles 1996 and newer when the check engine and ABS warning lights are on. Use read/erase hot keys to quickly view and erase codes and turn off the lights. Live data allows you to view vehicle sensor, switch and relay inputs in real time, while the engine is running. Live data information helps pinpoint the problem components for a faster diagnosis.



**COMING SOON**

**OBD I & II SCAN TOOL 3211**

OBD I & II tool for coverage on older GM, Ford, Chrysler and Toyota vehicles and that also works with all 1996 and newer cars and light trucks with 26 million+ CodeConnect Top Reported Fixes. Includes Oil Light and Battery Resets, ABS & Airbag/SRS Coverage. Graph two PIDs at same time. Read, record and playback live sensor data. Stores previous five vehicle's scan data.

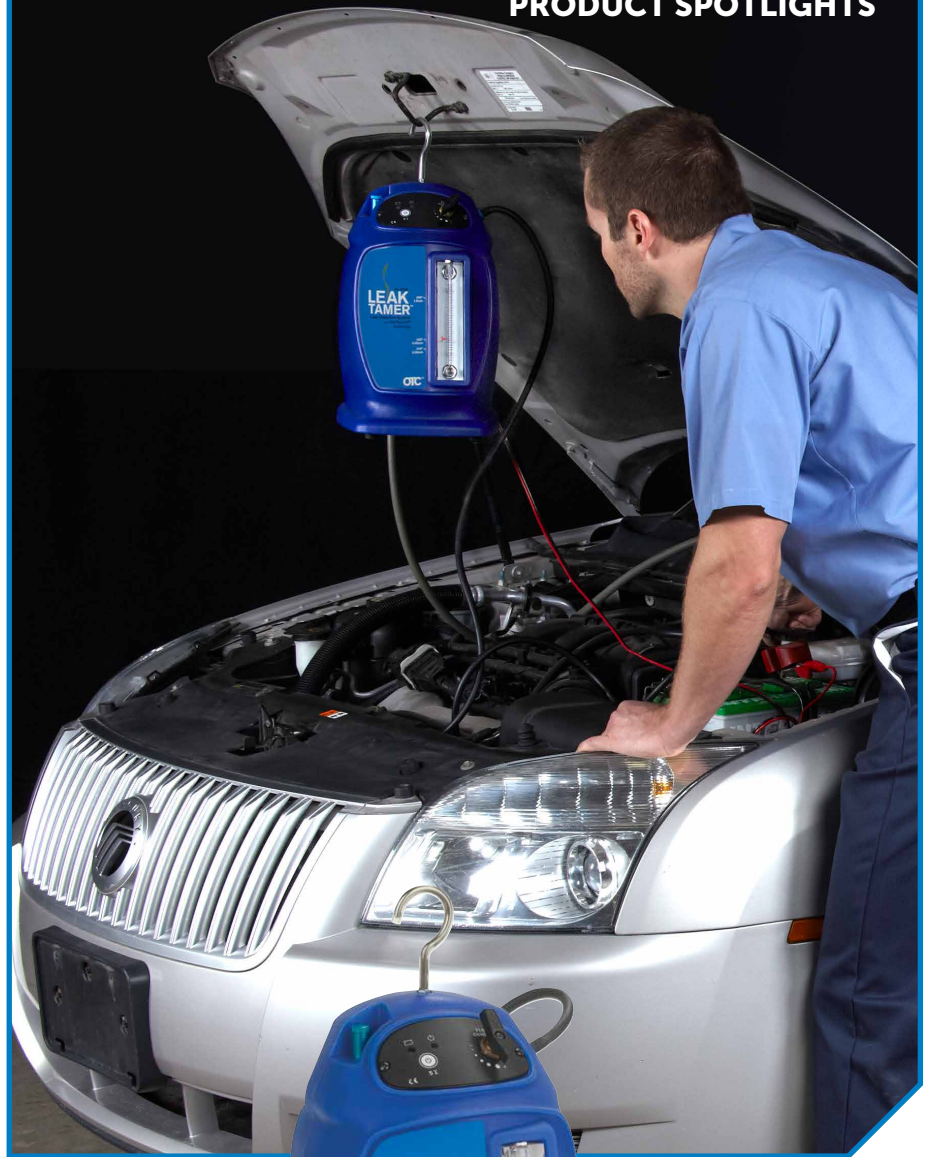

**OTC EVAP – LEAK DETECTION SYSTEM 6522**

Find the leak, clear the code, smoke the test. Put better technology and portability in your shop with OTC's new and improved smoke machine. Nearly 80% of top codes can be diagnosed with smoke technology. This unit is half the size and twice as mighty with more powerful features. Includes UltraTrace UV® dye, the only OE approved solution. Detects microleaks to and below .010".



**1000V CAT III HYBRID MULTIMETER 3990**

A full function multimeter with an insulation test feature is used to test for voltage leaks through insulation found on Hybrid and Electric Vehicles.

**BEST SELLER**



**TIRE PRESSURE MONITORING SYSTEM RESET TOOL 3834**

The OTC's TPR is a fast and simple-to-use standalone TPMS activation tool. Combine TPR activation with the power of Genisys and Encore diagnostics systems. Register new sensor IDs on Asian vehicles. Use the TPR to activate and decode sensor IDs and transmit them to the Genisys and Encore scan tools wirelessly. Bluetooth wireless communication adapter included.



**NEW**

**OBD II TPMS TOOL 3838**

Save time and perform additional diagnostic capabilities during tire service, tire rotations, tire sensor evaluations and TPMS sensor reset and relearn procedures. The OTC 3838 is both a sensor activation and diagnostic tool that features a wireless OBD II module for TPMS sensor registration. The tool works with all OEM and aftermarket sensors.

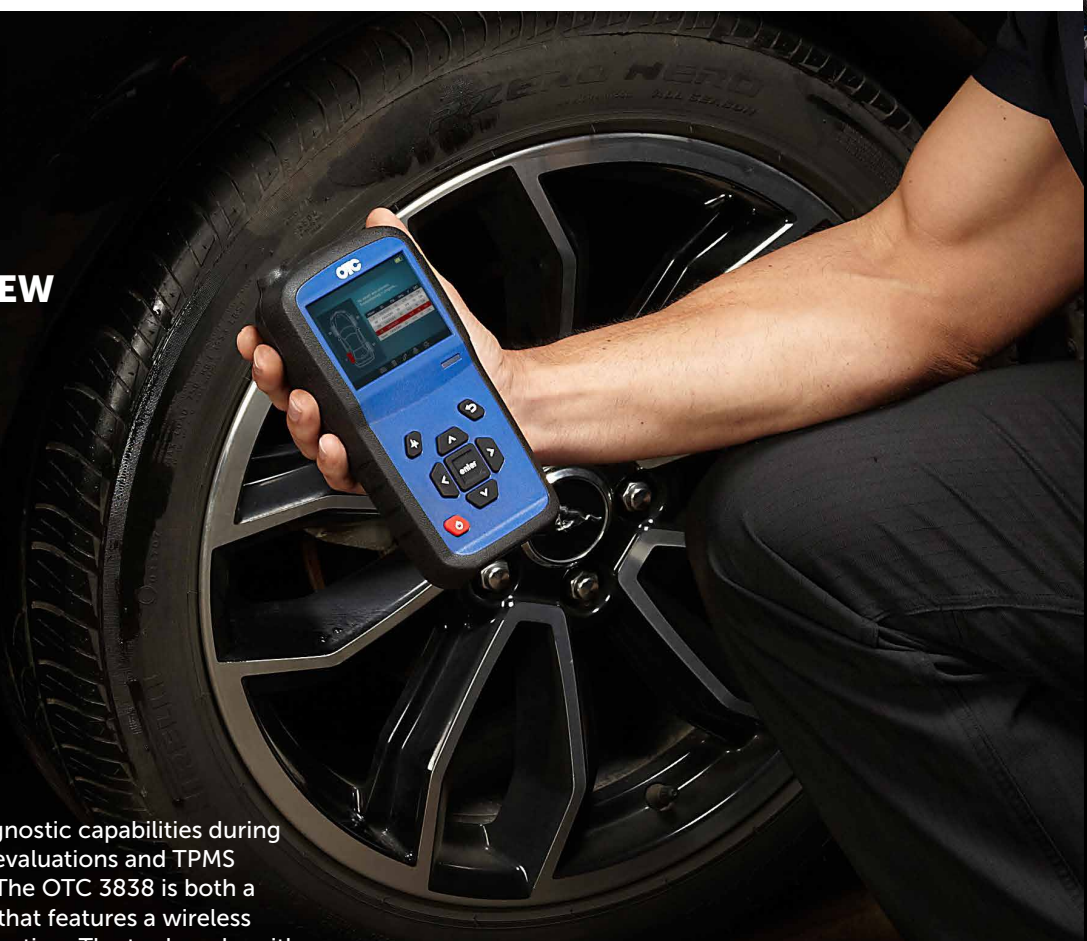

# CAPTURE BATTERY SERVICE OPPORTUNITIES

TOOLS DESIGNED TO FIX ALL  
MAKES, ALL MODELS



## 60-SECOND BATTERY TESTING

### OTC 3200 smart battery tester

- Test voltage, starting and charging system health in under 1 minute
- Tests 6V, 8V and 12V AGM and wet-cell battery types



## ALL-IN-ONE BATTERY SERVICE



### OTC 4631 battery terminal service kit

- Includes terminal wrenches, cable cutters and terminal puller
- Clean, replace or service most batteries with this 8-piece kit

## RESET CHARGING SYSTEMS TO EXTEND BATTERY LIFE

### OTC 3112 battery reset tool

- Perform reset procedures for BMW, Mini and Ford F-series
- AutoID pulls YMME for most vehicles.



## DIAGNOSE BATTERY OR ELECTRICAL PROBLEMS

### OTC 3167 Sabre HP battery/electrical system diagnostic tester

- Tests 6V and 12V AGM and wet-cell batteries with 50 - 2,000 CCA range
- Controlled load testing down to 1 volt state of charge



## PRODUCT SPOTLIGHTS

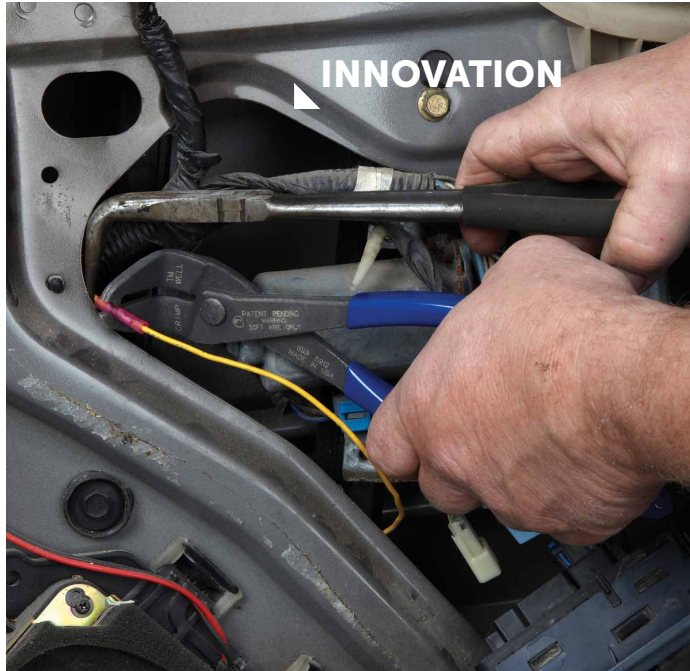

INNOVATION

### CRIMPWELL™ ANGLED CRIMPING PLIERS 5912

An innovative, simple-to-use tool for crimping terminal or joint connectors to common soft wire. The design of the wire crimpers makes cutting wire and crimping connectors easier than ever and is especially valuable when wire service is comprised by limited access. Universal crimping design accommodates soft wire – solid or stranded – 10-22 AWG. Angled design keeps the connector, wire and crimper in-line –improving visibility and access in hard to reach places. Service techs can use as much force as desired to ensure connection and it will not damage connector insulation.



NEW

### WEATHER PACK RATCHETING CRIMPER KIT 4484

Now you can manage environmentally sealed connection systems on vehicles with the OTC 4484 Weather Pack Crimper Kit. Weather Pack connection systems are designed to protect against exposure to heat, moisture and contaminants with unfaltering performance. The OTC 4484 comes with 2 interchangeable crimping dies, covering wire range AWG 22 / 20-18 (DIN: 0.35 / 0.5-0.8 mm<sup>2</sup>) and AWG 16-14 / 12 (Din: 1.0-2.0 / 3.0 mm<sup>2</sup>). The dies are easily interchanged and secured by strong ferrite magnets. The inside lid decal shows how to create a proper Weather Pack crimp seal. These connections are found on automobiles, Class 7-8 Tractors, motorcycles and other areas where weatherproof electrical connections are needed.

# TOOLS



AWARD WINNING

### LOCKING COLLAR RACK WRENCH 7485

Service steering linkage in place with this handy, time-saving tool designed to work with all component connections in one place. Simply remove one pin and place open collar around tie-rod end, steering knuckle or other components. Close collar and replace pin to lock around the component. A 1/2" square drive allows adjustment and leverage from a ratchet or breaker bar. No need to disconnect linkage for adjusting tool placement. Multiple applications from steering linkage, wheel alignment, small diameter exhaust and general pipe adjustment. Use with component diameters of 1" to 1-7/8" (25.4mm to 47.6mm). Ideal for steering service, wheel alignment, strut cartridge, small diameter exhaust and general pipe adjustment.

BEST SELLER



### S-CAM AIR BRAKE SPRING TOOL 5081

Eliminate makeshift, unsafe methods of unhooking and reconnecting retaining springs when replacing brake shoes on heavy-duty tractors and trailers. Simply hook the retaining spring loop and press down. Lever action against the axle makes the job a snap!



# SEE HOW THE ENCORE STACKS UP



Technicians have multiple scan tool brands to choose from. The OTC Encore is fastest at what counts, and that's fixing vehicles. No tool is faster at code-to-fix, pulling the DTC and showing the likely repair.

Request an Encore demo in your shop and fix faster than the usual suspects. Visit [otctools.com/fix-cars-faster](http://otctools.com/fix-cars-faster) today to have one of our diagnostics specialists visit your shop for a free demo.

## PRODUCT SPOTLIGHTS



### 4 PIECE ROLLING HEAD PRYBAR SET INCLUDES A FREE PAIR OF OTC SMARTTECH WORK GLOVES 7176

Includes 6", 12", 16" and 21" lengths for a variety of duties - small - large and in between. Heated to cherry red, upset, then forged and swaged processing creates the tool, then our special thermal treating process locks in the strength you count on. Won't bend or break.

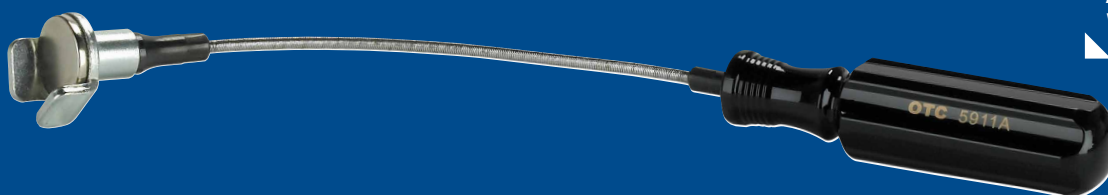

### OTC DRAIN PLUG PRO™ TOOL KIT 5911

Hot oil in the pan, not on your hand. Remove oil drain plug without touching the plug or hot oil. No touching a hot plug, hot oil on hands, no dropping of plug in hot oil and no oil soaked gloves. Just magnetically attach Drain Plug Pro™ to pre-loosened drain plug and rotate to remove plug. Includes multiple 1/4" internal square drive adapters for drain plugs of various shapes and sizes. The flexible shaft can also be used with other 1/4" internal sockets.

## INNOVATION



### CRIMPRO™ 4-IN-1 WIRE TOOL 5950S

Compact 7" straight wire crimps for nearly all automotive and other wire service jobs. Crimps, cuts and strips 12-20 AWG insulated and non-insulated wire.

## BEST SELLER



### CYLINDER LEAKAGE TESTER KIT 5609

Quickly diagnose internal engine problems such as bad rings, valves and leaking head gaskets. Kit comes complete with adapters for most applications.

## AWARD WINNING

### 3 PIECE PUSH PIN/BODY CLIP PLIERS SET 2497

Remove plastic body fasteners and clips faster in nearly any location. A set of three push pin / body clip pliers includes straight, 45° and 90° jaws to reach in wheel wells, under bumpers and behind the dash to remove retaining clips. The various jaw angles help access hard-to-reach places while providing maximum leverage to remove clips quickly and without damage. The unique design lifts the center pin and pulls body clips without damaging anchors, eliminating the need to provide replacement clips. Reusing these fasteners saves money and time searching for replacements of various shapes and sizes. The 3-piece set comes with an OTC lifetime warranty against defects in material or workmanship.



**NEW**



### FORD CAM TOOL KIT 6488

Ford cam tool kit for 1997 thru 2011 4.0L Explorer/ Mountaineer SOHC V6 engines. Kit contains tool Nos. 6478, 6479, 6480, 6481, 6482, 6484, 6485, and molded storage case.

### INNOVATION

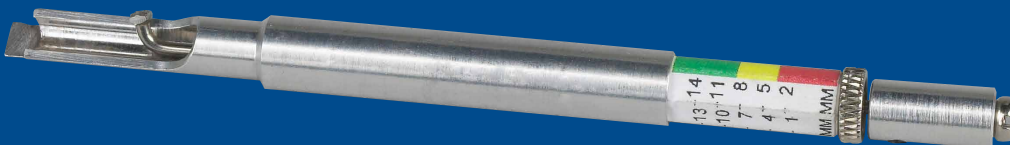

### BRAKE PAD GAUGE 6596

This tool allows for a definitive measurement of brake pads to determine remaining life. A unique design allows for measurement on the vehicle without the removal of any components in most cases (wheel assembly or brake caliper). Quick reference of brake pad condition via green-yellow-red color scale.



STRUT NOT INCLUDED

NEW

**STRUT TAMER II EXTREME 6637**

The 6637 Strut Tamer II Extreme sets a new standard in strength and safety for strut spring compressors. This unit meets the new ASME PASE safety standards for spring compressors and is capable of safely compressing the largest strut springs. A replacement for the Strut Tamer Extreme with improvements designed to provide quick and safe strut service for technicians.

- New forged locking jaws includes larger pads and offset to clamp onto and compress springs even tighter than before
- New extra thick 5/8" compression arms for superior strength, stability and safety
- New locking trunions for optimal stability during spring compression
- New arm-locking rings eliminate the need for tools to adjust

**STRUTTAMER II EXTREME WITH STAND 6637-ST**



**CRIMPRO™ 4-IN-1 ANGLED WIRE TOOL 5950A**

The angled feature allows access to close quarters and facilitates superior crimps. Compact 7" design can be used 4 ways. A gripping nose can pull, twist, bend, and shape most wires. Crimps and strips 12-20 AWG insulated and non-insulated wire. Cutter provides ability to make cuts both above and below pivot.



**UNIVERSAL OUTSIDE THREAD CHASER 7402**

Damaged bolt or nut threads can be an annoying, costly problem—unless you have one of our thread chasers. It will quickly restore threads to near original condition without the use of expensive thread-cutting equipment.

- Replaceable V-pads and dies.
- 1-1/4" to 5" O.D.



**MASTER TORX® BIT SOCKET SET, 52 PIECE 5900A**

52-piece professional socket set in a blow molded case covers the popular versions of Torx® specialty fasteners in the most used sizes. Styles include Torx® Bit Sockets, Torx® Plus Bits Sockets, Tamper-Resistant Torx® Bits and Torx® Socket for external bolts. Made from superior S2 steel to meet or exceed torque specifications. All bit sockets are a 2-piece design and are 20 percent stronger than a one-piece style for longer life.

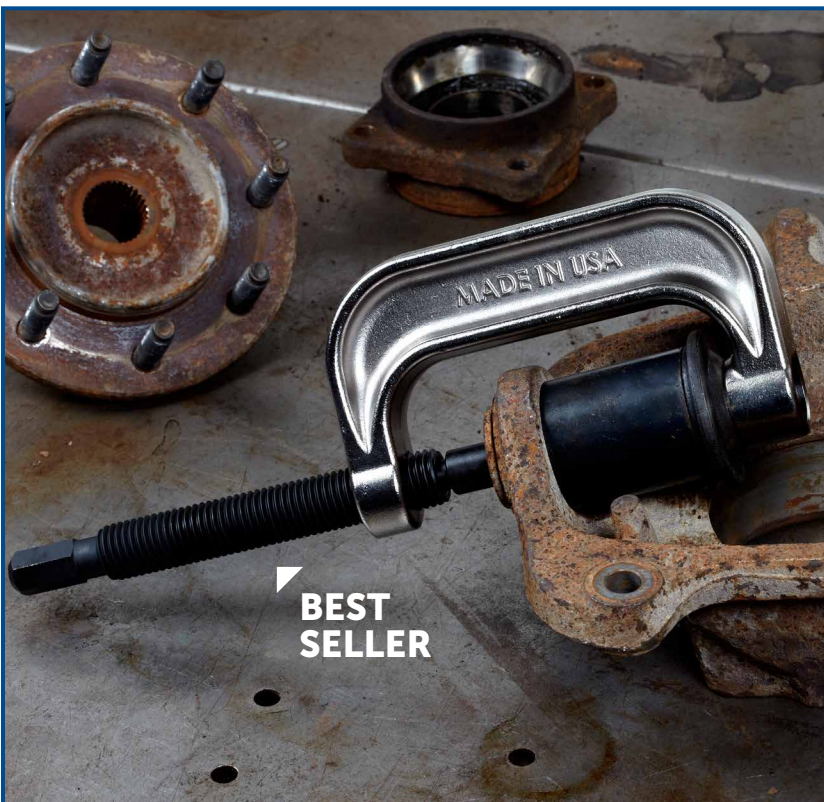

**BEST SELLER**

**BALL JOINT STARTER SERVICE KIT 7249**

This starter kit is the backbone to ball joint, U-joint, anchor pins, and many other general pressing operations. Kit includes 5 adapters and C-Frame provided in a case.



**NEW**

**HEAVY DUTY TIE ROD AND BALL JOINT PULLER 7503HD**

A universal heavy-duty puller that removes a wide range of tie rods and ball joints from a variety of cars, trucks, SUVs and heavy-duty vehicles. The 7503HD has a 10-ton pulling capacity, twice the force applied by the original 7503. Jaw spread and reach are increased to 3- and 4-inches for a wider variety of applications and larger vehicles. A heavy duty forcing screw, measuring 3/4" – 10, 6 1/2" long, includes interchangeable tips including cone, flat and cup for multiple applications. The tool will remove pitman arms and can be used in many situations that require a 2-jaw puller on vehicles and machinery.

**INNOVATION**



**FORD SPARK PLUG REMOVER KIT, 3V ENGINE 6918**

Finally, a Ford spark plug remover tool designed to not break the spark plug in the first place. Unlike similar tools designed to remove the spark plug once it's broken, this tool is designed to prevent breakage of the spark plug. Unique design helps prevent breakage by locking the plug porcelain core to the plug hex allowing it to turn as one complete unit. Will also pull plug porcelain core if plug hex only is removed.



**HUB GRAPPLER™ KIT 6575**

The complete solution for servicing wheel hubs and bearings on the vehicle without removing the steering components or knuckle. This eliminates unnecessary alignments or the use of a shop press, cutting service time dramatically. Jaws are designed and sized to properly fit hub applications and are quickly adjusted on the puller bar using high-strength steel tension clips. Six adapters increase application coverage. Includes tie rod/ball joint tool and two Ford axle installers.

## PRODUCT SPOTLIGHTS



### 10 TON END LIFT 1590

Adjustable lifting saddle and lifting range from 13" to 52" services a variety of vehicles. Automatic mechanical safety catch engages in (5) height positions. Lifting range is 13" to 52".

**BEST  
SELLER**

### TRUCK CLUTCH AND FLYWHEEL HANDLER 5018A

Handles 14" and 15-1/2" clutch assemblies weighing up to 250lbs. Swivel casters provide easy maneuverability. Includes a 2" splined shaft with a 1-1/4" pilot to aid in alignment and 360-degree swivel head. Minimum height of 15 degrees allows access below side faring. When raised, centerline of clutch will be 38-1/4" off floor. Floor space is 32-3/8" long by 24-1/2" at widest point.



**INNOVATION**

# EQUIPMENT



**BEST  
SELLER**

### 2,200 LB. CAPACITY LOW-LIFT TRANSMISSION JACK 5019A

The 8-1/4" low height is perfect for aerodynamic trucks with low ground clearance. Special mounting adapter (No. 49611) fits popular Eaton® Fuller® RoadRnager® transmissions used on nearly all Class 7 and 8 heavy-duty trucks. Mounting plate angle is adjusted with the turn of a wrench. Tilts 20 degrees back, 15 degrees forward and 12 degrees side to side. Swiveling pump handle permits ease of operation in restricted working spaces. Fast-acting pump quickly raises lifting arm.



**NEW**

### TWO TON ALUMINUM RACING JACK 1532A

This low profile jack is perfect for use with performance cars that have low ground clearance. Its two speed design reaches full height in just 5 pumps. With carrying handles, a 2-piece handle, and light-weight aircraft grade aluminum construction, vehicle service can become less of a chore. Its removable rubber saddle protects vehicles and prevents slipping. ASME-PASE-2014 Compliant.

# 60 years of A/C service

A full line of A/C machines and accessories to find leaks, test system pressure, recover and recharge A/C systems and more.



## Recovery Machines

34788NI

- › The most efficient machine in North America
- › Fully automatic function
- › 34788NI-H model for high-voltage systems in hybrid and electric vehicles

## Vacuum pumps

15300 3 CFM pump

- › Offset rotary vane for fast, full evacuation
- › Lifetime filtration prevents chamber contamination

## Leak detection

22791 Infrared leak detector

- › Sensor designed to last at least 10 years
- › Senses CFC, HFC, HCFC blends and HFO-1234yf refrigerants

## Accessory bundles

48134B-DYEKIT

- › R134A and R12 brass manifold set with 6' hoses
- › UV dye and injection gun for leak detection

**ERIC THE CAR GUY**

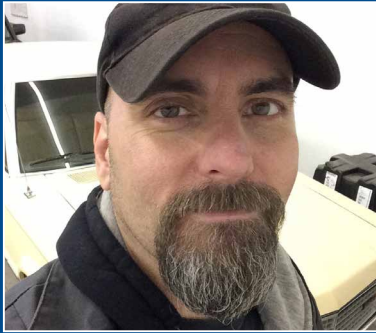

**ERIC COOK**  
ERICTHECARGUY.COM



# TOOL TALK WITH ERIC COOK OTC HUB GRAPPLER 6575

**AKA EricTheCarGuy on YouTube**

Greetings readers! I'm Eric, owner of EricTheCarGuy.com as well as the EricTheCarGuy YouTube channel. I have been into cars for as long as I can remember, and really enjoy sharing my passion. My YouTube channel is dedicated to posting the best auto repair videos I can possibly make, and giving viewers a helpful resource to use when tackling do-it-yourself projects on their cars at home.

In one of my recent videos, I was working on my friend and cameraman Brian's Toyota 4Runner to remove his hubs and wheel bearings. I fought relentlessly hammering away to remove the wheel bearings and they simply would not come apart. That's why I was thrilled when I got my hands on OTC's Hub Grappler. In order to truly test its capabilities, I decided to take out Brian's old, discarded hubs that I still had in my shop, and decided to use OTC's Hub Grappler to see if the tool could make the process any easier.

With my wrench in hand, I turned the OTC Hub Grappler on and watched as the tool extracted the hub with ease in a matter of seconds. Since then, I've used OTC's Hub Grappler a few more times, and I'm very happy with it overall. When I have the opportunity to use it, OTC's hub grappler tool works extremely well and is a huge time-saver.



**" WHEN I HAVE THE OPPORTUNITY TO USE IT, OTC'S HUB GRAPPLER TOOL WORKS EXTREMELY WELL AND IS A HUGE TIME-SAVER."**

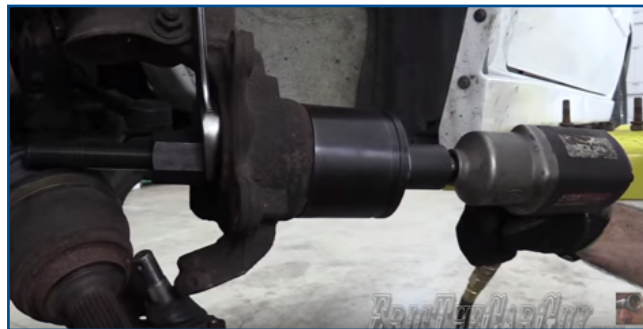

In my opinion, OTC's Hub Grappler kit is very durable and reliable. The 90-lb kit is equipped with many attachments for different applications. I particularly liked that the treads on the nuts were high, making it easy to get onto the bolt. To get familiar with the parts and uses, OTC provides a detailed, easy-to-use manual for the entire set featuring detailed diagrams and lists of applications – OTC is definitely focused on helping to build technician confidence through their products and corresponding manuals.

**I hope you enjoyed my review of the OTC Hub Grappler and until next time--be safe, have fun, don't forget to play with your tools, and stay dirty, my friends!**

**-Eric The Car Guy**





# REDUCE SERVICE TIME

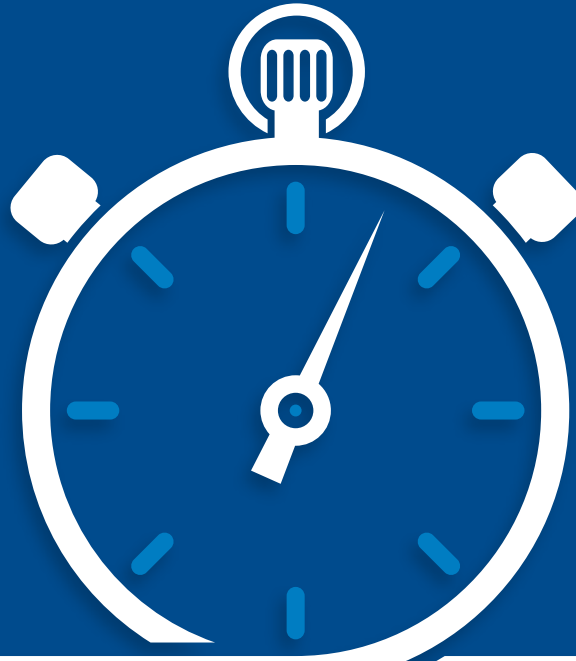

## FOR HENDRICKSON HD SUSPENSION BUSHING SERVICE

### *OTC 4246 and OTC 4247 Hendrickson Suspension Bushing Tool Kits*

The patent-pending OTC 4246 Hendrickson Suspension Bushing Tool Kit and OTC 4247 Hendrickson Suspension Bushing Master Kit with Pump are designed to remove frozen Pivot and D-pin bushings on Hendrickson Primaax EX, Comfort Air and FCCC V-Ride™ suspensions. Kit 4246 includes adapters, and an OTC 4106A 25-ton high-force cylinder. Kit 4247 also includes the OTC 2510A air/hydraulic pump, hose and couplers to put the tool into service immediately.

#### **BENEFITS:**

- Reduces service time to remove and install heavy-duty rear suspension bushings
- Easy-to-use design eliminates the need to hold up the tool during use, reducing technician fatigue
- Alignment adapters reduce the likelihood of improper bushing installation and potential bushing damage

#### **APPLICATION TIPS:**

- Refer to manual to verify that appropriate adapters are used for proper mounting of tool to suspension
- Follow manual by bushing type for correct adapters and orientation for removal and installation of bushings.



## NEW HYDRAULIC FLOW METERS



### 50 GPM MECHANICAL HYDRAULIC FLOW METER 4277

Provides unparalleled accuracy in testing hydraulic flow circuits from 4 to 54 GPM for industrial and agricultural machinery. With its fluid filled gages that dampen vibration and precisely manufactured components, it can measure flow accurately within 4 percent of full scale. Due to its inner pass system, which includes extra burst discs, overpressure conditions won't lead to hydraulic fluid spills and the components can accommodate bidirectional flow, reading flow in one direction.



### 100 GPM DIGITAL HYDRAULIC FLOW METER 4278

Provides unparalleled accuracy in testing hydraulic flow circuits from 2.5 to 100 GPM for industrial and agricultural machinery. Otherwise similar to 4277 including burst discs to prevent hydraulic fluid spills.



### DELUXE HYDRAULIC FLOW SET 4294

Comprised of OTC 4290, OTC 4291, OTC 4292, Long Cable and Hose Set and Short Cable, case included.



### DIGITAL HYDRAULIC FLOW TEST KIT, 100 GPM 4285

For remote testing applications, the OTC 4285 provides unparalleled accuracy in testing hydraulic flow circuits from 2.5 to 100 GPM for industrial and agricultural machinery.

## NEW SINGLE ACTING CYLINDER RAMS

|       |                                 | CAPACITY<br>IN TONS | STROKE  | HEIGHT    |           |
|-------|---------------------------------|---------------------|---------|-----------|-----------|
|       |                                 |                     |         | COLLAPSED | EXTENDED  |
| 4100A | 5-Ton Single Acting Cylinder    | 5                   | 3"      | 5-11/16"  | 8-11/16"  |
| 4101A | 5-Ton Single Acting Cylinder    | 5                   | 5-1/4"  | 10-7/16"  | 15-11/16" |
| 4103A | 10-Ton Single Acting Cylinder   | 10                  | 2-1/8"  | 5-9/16"   | 7-11/16"  |
| 4104A | 10-Ton Single Acting Cylinder   | 10                  | 6-1/8"  | 11-1/2"   | 17-5/8"   |
| 4105A | 10-Ton Single Acting Cylinder   | 10                  | 10-1/8" | 15-1/2"   | 25-5/8"   |
| 4106A | 25-Ton Single Acting Cylinder   | 25                  | 6-1/4"  | 13-3/8"   | 19-5/8"   |
| 4107A | 25-Ton Single Acting Cylinder   | 25                  | 14-1/4" | 21-3/8"   | 35-5/8"   |
| 4108A | 5-Ton LP Single Acting Cylinder | 5                   | 9/16"   | 1-5/8"    | 2-3/16"   |
| 4110A | 55-Ton Single Acting Cylinder   | 55                  | 6-1/4"  | 11"       | 17-5/16"  |



### 22-TON CAPACITY UNDER-AXLE JACK 1788B

Long 49-1/2" T-handle lets you easily position jack under vehicles with long overhangs. One pull of the handle activates the self-retracting 22-ton capacity ram without having to crawl underneath the vehicle. Large rubber wheels provide stability, portability, strength and durability.



**BEST  
SELLER**

**NEW**



4012A

4000A

### TWO-SPEED LARGE CAPACITY HYDRAULIC HAND PUMP 4012A

This two-speed hand pump develops up to 10,000 PSI and has a built-in safety overload valve. It has a comfortable carrying handle, pumping handle grip and contoured release knob. The CE-compliant pump automatically switches from low to high-pressure mode and may be operated horizontally or vertically in the "head down" orientation.

### TWO-SPEED HYDRAULIC HAND PUMP 4000A

This two-speed pump uses single-acting cylinders, requiring fewer handle strokes than single speed pumps, saving time and effort. It develops up to 10,000 psi of operating pressure and has a built-in safety overload valve. The CE-compliant hydraulic pump automatically switches from low to high pressure mode and may be operated horizontally or vertically in the "head down" orientation. CE compliant.



**NEW**

### HENDRICKSON REAR SUSPENSION BUSHING TOOL KIT 4246

Replace rusted and frozen heavy-duty rear suspension bushings faster and easier with our patent-pending suspension-mounted removal tool. Remove and install Hendrickson PRIMAAX EX, COMFORT AIR, FCCC V Ride™ Pivot and D-Pin Bushings without having to hold the tool during operation.

Included adapters align tool with the suspension to ensure proper bushing installation and reduce the chance of misalignment and bushing damage  
Includes an OTC 4106A 25-ton high-force cylinder

**NEW**



### HENDRICKSON REAR SUSPENSION BUSHING TOOL KIT WITH PUMP 4247

Same as 4246 and includes an OTC 2510A air/hydraulic pump to make bushing service faster and easier



**BEST  
SELLER**

### 6000 LB. REVOLVER® DIESEL ENGINE STAND OTC 1750/1750A

96-to-1 ratio worm gear rotates components 360° while the handle locks in any position. Integrated 12-ton jack raises the work to provide the swing radius needed for clearance. Two front wheels and two rear casters provide mobility. Universal adapter assembly permits use with a wide variety of mounting plates. Covered by OTC Lifetime Marathon Warranty®.

### 1750A REVOLVER DIESEL ENGINE STAND WITH NO. 205061 UNIVERSAL ENGINE ADAPTER ASSEMBLY.

### 1750 ENGINE STAND WITHOUT UNIVERSAL ENGINE ADAPTER ASSEMBLY.

# LOOKING TO THE FUTURE



# WITH A TRIBUTE TO THE PAST

Fabricator, welder, builder, designer, business owner and all-around motorhead Bryan Fuller teams with OTC to build a throwback tool truck. Inspired by the original 1920s OTC salesmen, Fuller reimagined the delivery into a modern, eye-grabbing mobile showroom.

Paying homage to the 91-year history of OTC, Bryan Fuller went in search of a 1930s era Ford delivery truck, eventually finding one in Mechanicsville, Va. (*yep you can't make that up!*). Willy Glass a Bonneville 200mph record holder, used it to promote his welding supply business. Seems it was built in the late 70s or early 80s by a very capable team.

Once back in the Fuller Moto garage, Bryan and his team had the unenviable task of finding all the surprises that arise from disassembling an 80-year-old vehicle. They discovered a gem, in every sense of the word. The truck was rust-free, and believe it or not, dent-free too! The wood was perfect and everything came apart easily!

"Remember not only is this truck 80-some-odd years old, but these were commercial vehicles...they were beat on," said Fuller. "Lead work on this vehicle was so good, we didn't even remove it. That's a first in my career."

Fuller and crew had all of the paint stripped, and luckily it came off easily. Loose parts were powder coated in prep for bodywork and OTC blue paint. A few minor metalworking tricks were done to clean the body up including filling some seams and removing cowl lights.

The interior? Another story. Tuck-and-roll velvet lined the inside of the truck, a throwback to an update in the 1980s. Thankfully Fuller didn't have to dispose of shag carpeting, though they did find some interesting thatch-like covering under the roof.

A well-running 302 Ford powered the delivery to speeds not thought of when it rolled off the assembly line, mated to a C-4 automatic transmission.

The truck will make its debut at SEMA 2016 in the OTC booth, # 10171 in North Hall. Stop by to see the truck and Fuller, with plenty of before and after photos and a unique tribute to OTC, one of America's great tool companies.



**Bryan Fuller** has a Biology Degree as well as having graduated from WyoTech. Right after that, he began working for Chip Foose, and served as a Builder for his shop, and on the Overhauled series on TLC.

Following that, he moved to Atlanta, opened his own shop, and became the Co-Host of "Two Guys Garage" on the Speed Channel. The show, including reruns, averaged 1 million viewers per week.

Keep an eye out for Bryan on the Velocity Channel soon on a new show called "Caffeine and Octane" debuting February 2017!

## SEE IT LIVE

**WHERE:** SEMA 2016  
Las Vegas Convention Center, North Hall  
Las Vegas, Nevada

OTC Tools booth, #10171

**WHEN:** November 1 – 4, 2016

**WHAT ELSE:** Tools, equipment and diagnostics from OTC and sister brands Robinair, Bosch and Actron

**WIN BIG:** Compete against other technicians using OTC diagnostic tools to win daily prizes, including an OTC Encore diagnostics system.

**MORE:** Stop by the OTC booth to claim your custom-made bottle opener, forged in Owatonna, Minnesota. The forge team created each one, using the same drop forge hammer used to form the legendary OTC pullers.

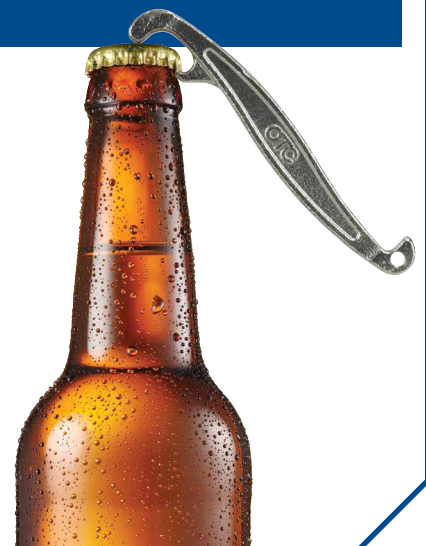

# COMPLETE COLLISION REPAIR

## OTC'S LINE OF PAINLESS DENT REPAIR BODY TOOLS PROTECT PANELS DURING REPLACEMENT, RESKINNING AND RESHAPING



### 2470 SPOT WELD BREAKER

Separate panels after drilling spot welds during replacement or reskin jobs. Combine with 2492 spotweld carbide drill bit set or 2489-8 single spotweld carbide bit to quickly repair or replace panels.



### 2481 BLIND PANEL REMOVAL WEDGE

Extended-reach tool helps reach inside panel release points for removal. Thin, strong construction reaches tight access points with plenty of leverage. Removal wedges include 2479 30mm wedge, 2480 60mm wedge, 2487 combination wedge pry tool and 2491 stepped lever wedge



### 2482 120MM X 30MM PICK HAMMER

Fully synthetic construction protects body panels during reshaping, eliminating damage and marring paint. Available in a larger size, 2483 140mm x 40mm for a variety of applications.



### 2473 HALF-ROUND BUMPING TOOL

Reshape rounded metal profiles in confined areas without scratching or marring paint. Additional bumping tools from OTC are 2474 profile straightening tool, 2475 round body anvil, 2477 edge straightener and 2476 curved and flat dolly



### 2485 3-PIECE BUMPING TOOL SET

Versatile set includes a door aligner, center punch and straightener for common collision repair jobs. Add the 2478 extended reach bumping tool to reach door skins, panels, hood and deck lids for nearly any repair



### 2472 WINDOW TRIM AND MOLDING REMOVER

Safely remove fragile trim pieces like chrome window trim and reuse it with this tool. Other synthetic tools include 2471 trim and bezel tool and 2490 universal hook to remove and prevent damage to delicate trim pieces.

# LOOKING FOR AN OTC PRODUCT?

OTC tools and equipment are sold through distribution partners, resellers and at retailers. Visit [OTCtools.com](http://OTCtools.com) to learn more.

## DISTRIBUTORS

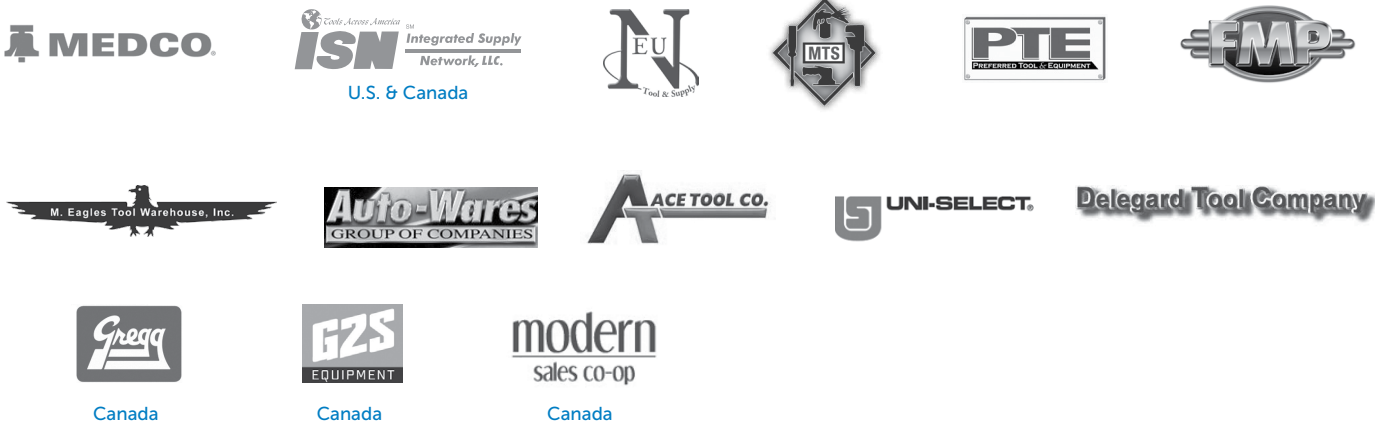

## RETAIL



## MOBILE DISTRIBUTORS



## HEAVY DUTY DISTRIBUTORS



# OTC'S HERITAGE

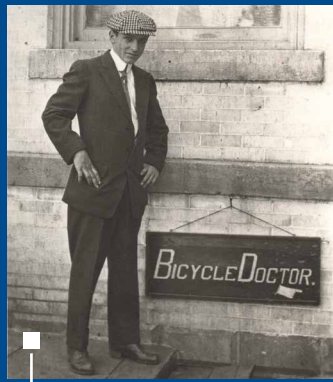

At age 16, Reuben A. Kaplan opened his own bike repair shop and called himself "The Bicycle Doctor"

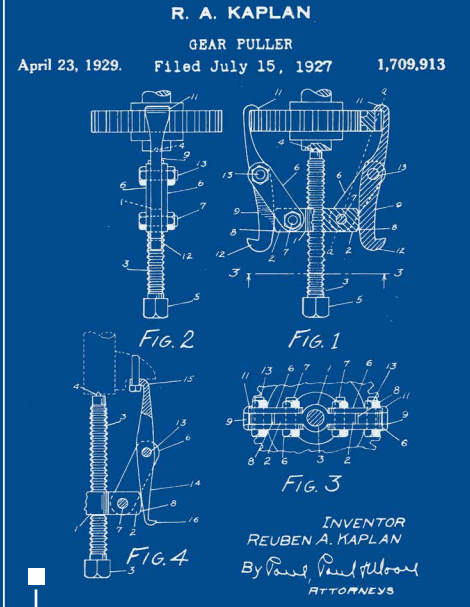

Reub's inventive mind produced this gear puller design, patented in 1927. It is still being manufactured by OTC with few changes from the original.

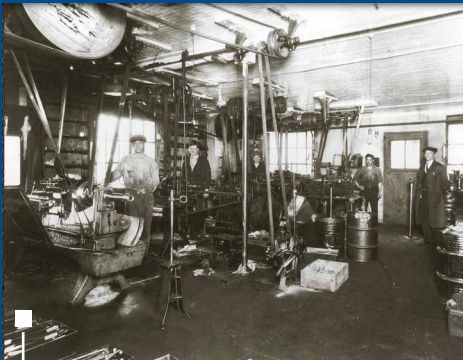

Early machine shop photo

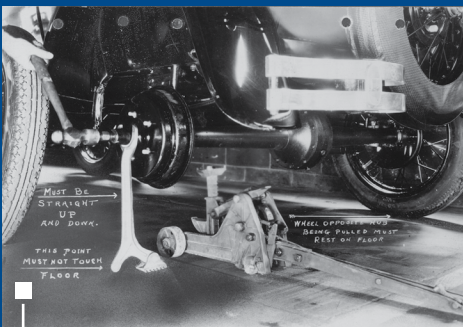

Ford Model T planetary transmission

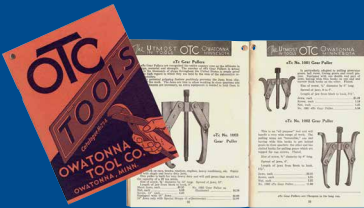

## 1925

Owatonna Tool Company (OTC) founded by Reuben Kaplan

## 1927

Special tool developed for Model T planetary transmission

## 1935

OTC sells tools to mechanics from modified trucks and autos

## 1942

Tools shipped by rail to service military vehicles, planes and ships

## 1950s

As pullers increased in size, the amount of torque increased as well. Reuben Kaplan had the solution: hydraulic power

## 1956

Large new factory built in Northwest Owatonna, MN

## 1971

OTC acquires the Tri-Mark (Lynor) Company



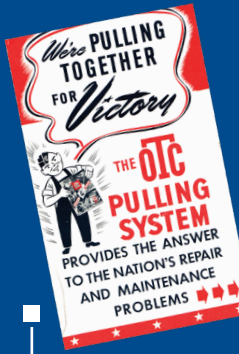

Ads announced to America that OTC's production was devoted completely to providing tools for the war effort.



Giant wrenches, such as this one, were manufactured in large numbers for the U.S. Navy during World War II. Ruth Ann Piskey, who worked in the shipping department, posed with the wrench to show just how big it really was.

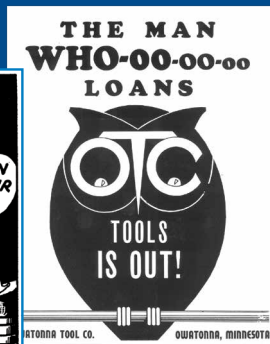
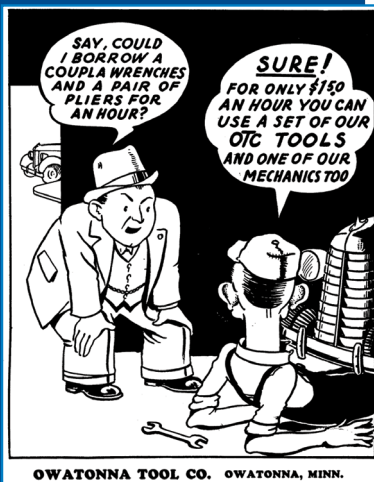

Two examples of small posters OTC offered free of charge to any garage or service station mechanics who requested on.

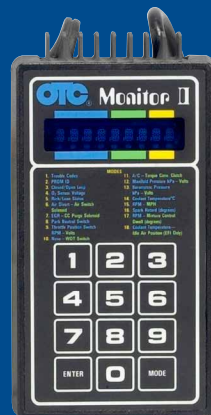

In 1985, OTC engineers decipher code, enabling the Monitor 2000 to communicate with new vehicle computers.



In 2016, OTC launches a scan tool powered by Bosch, a world leader in automotive technology, on every vehicle all over the world.

**1978**

OTC introduced a new design for the OTC logo

**1985**

OTC and subsidiaries are acquired by Sealed Power Corporation

**1988**

Sealed Power Corp. changes name to SPX Corporation

**1997**

SPX's Specialty Tools and OEM business groups combined to become a new business unit called Service Solutions

**2008**

SPX launches global tool platforms to serve the global market

**2012**

OTC becomes part of the Bosch Automotive Service Solutions portfolio of brands

**2016**

OTC - Innovation in vehicle service solutions for **91 YEARS!**

# BEST-IN-CLASS FIELD SUPPORT

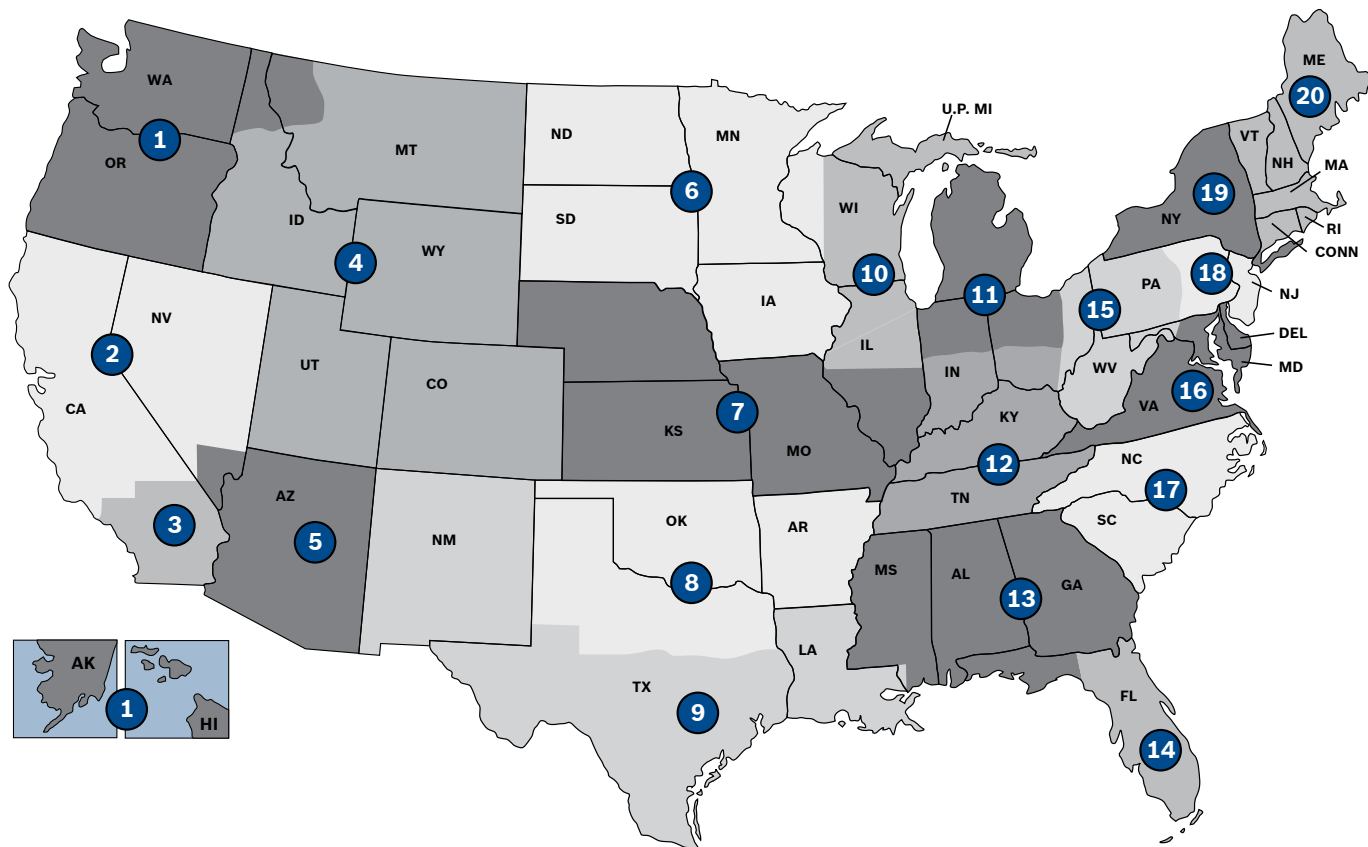

OTC and Bosch boast a nationwide group of automotive experts with more than 350 years of combined experience. Our Field Technical Sales, or FTS, team have worked as technicians, service managers, shop owners, OEM technical instructors, mobile tool dealers and more. They routinely hold training courses across the country, teaching technicians and shop owners how to diagnose and repair vehicles faster with the right tools. To find a training session near you and learn from our expert instructors, visit [OTCtools.com/field-support](http://OTCtools.com/field-support)

## Technical Sales Specialist

|    |                   |                       |   |
|----|-------------------|-----------------------|---|
| 1  | Scott Davis       | Phone: (509) 572-5619 | Email: <a href="mailto:scottd.davis@us.bosch.com">scottd.davis@us.bosch.com</a>                   |
| 2  | Sam Pok           | Phone: (562) 547-3454 | Email: <a href="mailto:sam.pok@us.bosch.com">sam.pok@us.bosch.com</a>                             |
| 3  | Sam Pok           | Phone: (562) 547-3454 | Email: <a href="mailto:sam.pok@us.bosch.com">sam.pok@us.bosch.com</a>                             |
| 4  | Scott Davis       | Phone: (509) 572-5619 | Email: <a href="mailto:scottd.davis@us.bosch.com">scottd.davis@us.bosch.com</a>                   |
| 5  | Sam Pok           | Phone: (562) 547-3454 | Email: <a href="mailto:sam.pok@us.bosch.com">sam.pok@us.bosch.com</a>                             |
| 6  | John Schommer     | Phone: (320) 247-8196 | Email: <a href="mailto:john.schommer@us.bosch.com">john.schommer@us.bosch.com</a>                 |
| 7  | Joe Barton        | Phone: (636) 688-0053 | Email: <a href="mailto:shelby.barton@us.bosch.com">shelby.barton@us.bosch.com</a>                 |
| 8  | Richard Zenteno   | Phone: (512) 639-3107 | Email: <a href="mailto:richard.zenteno@us.bosch.com">richard.zenteno@us.bosch.com</a>             |
| 9  | Mike Whittington  | Phone: (512) 621-5719 | Email: <a href="mailto:mike.whittington@us.bosch.com">mike.whittington@us.bosch.com</a>           |
| 10 | Mike Schoenbeck   | Phone: (262) 237-3810 | Email: <a href="mailto:michael.schoenbeck@us.bosch.com">michael.schoenbeck@us.bosch.com</a>       |
| 11 | Ed Carpenter      | Phone: (330) 316-7530 | Email: <a href="mailto:ed.carpenter2@us.bosch.com">ed.carpenter2@us.bosch.com</a>                 |
| 12 | Guy Garrett       | Phone: (937) 361-5211 | Email: <a href="mailto:guy.garrett@us.bosch.com">guy.garrett@us.bosch.com</a>                     |
| 13 | Marshall Townsend | Phone: (407) 314-4519 | Email: <a href="mailto:marshall.townsend@us.bosch.com">marshall.townsend@us.bosch.com</a>         |
| 14 | Frank Ranken      | Phone: (386) 274-8734 | Email: <a href="mailto:frank.ranken@us.bosch.com">frank.ranken@us.bosch.com</a>                   |
| 15 | Nick Zappitelli   | Phone: (216) 392-0559 | Email: <a href="mailto:nick.zappitelli@us.bosch.com">nick.zappitelli@us.bosch.com</a>             |
| 16 | Lee Brewer        | Phone: (540) 395-1262 | Email: <a href="mailto:lee.brewer@us.bosch.com">lee.brewer@us.bosch.com</a>                       |
| 17 | Chris Ellington   | Phone: (770) 324-9426 | Email: <a href="mailto:christopher.ellington@us.bosch.com">christopher.ellington@us.bosch.com</a> |
| 18 | Nick Zappitelli   | Phone: (216) 392-0559 | Email: <a href="mailto:nick.zappitelli@us.bosch.com">nick.zappitelli@us.bosch.com</a>             |
| 19 | Chris Hınca       | Phone: (716) 560-0568 | Email: <a href="mailto:christopher.hinca@us.bosch.com">christopher.hinca@us.bosch.com</a>         |
| 20 | Brett Sanelli     | Phone: (860) 917-1730 | Email: <a href="mailto:brett.sanelli@us.bosch.com">brett.sanelli@us.bosch.com</a>                 |



**Scott Davis**  
**Position:** Field Technical Sales  
**Background:** Scott is a 34-year veteran of the automotive industry. He has spent time as a tech in dealerships, general repair, body shops and specialty fabrication shops. Davis has been a trainer for the past 15 years focusing on diagnostics and A/C.  
**Certification:** MACS Certified Proctor, past ASE certified  
**In my spare time:** 'I enjoy all forms of motorsports and raced Superlate Model Stock Cars and am a former nationally ranked expert Jet Ski racer.'

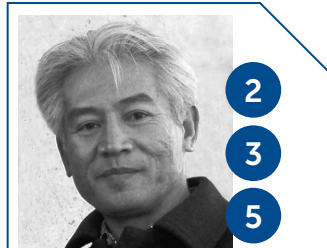

**Sam O. Pok**  
**Position:** Field Technical Sales  
**Background:** Pok has worked for OTC and Robinair for the past 33 Years. He started as a field service Tech and was promoted to Field Service Manager. He then spent 10 years as a Regional Technical Trainer and 13 years as a Technical Sales Specialist  
**Certification:** Electronic Technician Diploma. EE( Electrical Engineer) background. ASE Certified Electrical A6. State of California I/ M OBDII, Certified.  
**In my spare time:** 'I Migrated from Cambodia, after the Vietnam War in 1979 and two years later started working for OTC. I play golf left handed and am a Los Angeles Lakers fan.'



**John Schommer**  
**Position:** Field Technical Sales  
**Background:** Schommer has spent 20 years as an automotive/ medium truck technician specializing in under chassis, vehicle drivability and collision work. He also spent 8 years in sales in the wholesale tire industry helping customers grow their business by bringing them continued value added services and training.  
**Certification:** TIA Advanced Instructor Level 400  
**In my spare time:** 'I consider staring down a hole in a frozen lake for hours on end fun.'



**Joe 'Shelby' Barton**  
**Position:** Field Technical Sales  
**Background:** Joe entered the automotive business in 1967 after a tour of duty as a Navy aircraft mechanic and crewman. He is a former shop owner and instructor at Bailey Technical Institute. Barton has dedicated his career to helping technicians, setting up ASA chapters in multiple states and managing national training programs for several companies.  
**Certification:** Master Trainer certified in the federal ATTP program, ASE Master certified (Current), MACS Certified  
**In my spare time:** 'I now have the best of all worlds; I am doing what I like best and am on the leading edge of technology with Bosch and OTC.'



**Richard Zenteno**  
**Position:** Field Technical Sales  
**Background:** Zenteno joined Bosch and has more than 13 years of experience in the auto industry. He has worked as a technician and also has technical marketing and sales experience. He excels at channel development and training in the Tool and Equipment segment.  
**Certification:** Certified in Medical Device Repair, Installation and Training; Computer Hardware Servers and other Networking, Undergraduate Marketing and Engineering background, MBA from Baylor, CAN Networking in European vehicles, BMW Coding and Reprogramming, VW Diagnostics Data Blocks.  
**In my spare time:** 'I love music and sports, especially soccer, and my road bike is my passion. I play guitar and drums and love Italian food.'



**Mike Whittington**  
**Position:** Field Technical Sales  
**Background:** Whittington has spent the last seven years with Bosch as an ASR/TSS. Previously he was an outside salesman for a warehouse distributor focusing on fleet and Installer sales and worked for five years as a store manager for a major auto supply company. He also served four years in the US Army.  
**Certification:** ASE Parts Specialist  
**In my spare time:** 'I enjoy golf, fishing and coaching football.'



**Michael Schoenbeck**  
**Position:** Field Technical Sales  
**Background:** Michael Schoenbeck started his automotive career as a technician and moved to another tool manufacturer, serving as a Hand Tools, Diagnostic Equipment and Air Conditioning expert for 10 years. Prior to that he was a Tools Product Manager with a small but growing tool company. Started automotive career as a technician.  
**Certification:** Past ASE Master and L1, Member of SAE  
**In my spare time:** 'I can't get enough of muscle cars.'



**Ed Carpenter**  
**Position:** Field Technical Sales  
**Background:** Ed has spent more than 30 years in the Automotive Aftermarket. He's done it all, working as a Technical Trainer, Shop Owner, Regional Sales Manager and more through the years. Carpenter has also won national awards for Training and Sales.  
**Certification:** Previous ASE Master Tech  
**In my spare time:** 'I'm a football and car guy'

## FIELD TECHNICAL SALES



12

### Guy Garrett

**Position:** Field Technical Sales

**Background:** Garrett has been a Bosch diagnostics trainer and sales specialist for the past seven year. Previously, he was a Regional Training Manager for a major tool manufacturer and ICAR. He has more than 25 years of experience in the Automotive OEM and Aftermarket

**Certification:** ASE Certified, ICAN Certified Instructor, MACS Certified Instructor

**In my spare time:** 'I live in Ohio with my wife and two boys and spend my time at home sharing my love of youth sports, photography and music with my family.'



13

### Marshall Townsend

**Position:** Field Technical Sales

**Background:** Townsend has more than six years of experience with OTC and Robinair products. Prior to joining Bosch he worked for four years at the AAA national office, 11 years as a technical trainer for a major OEM and 10 years as a technician and shop foreman.

**Certification:** ASE Automotive Master certified with L1 Advanced Engine Performance.

**In my spare time:** 'I enjoy woodworking and fixing things around my house.'



14

### Frank Ranken

**Position:** Field Technical Sales

**Background:** Prior to joining Bosch for the second time, Ranken was an automotive repair shop owner for seven years, a tech rep and dealer for a major tool manufacturer for 12 years and an ASR with Bosch.

**Certification:** ASE Master L1, Master Truck 1975-2005

**In my spare time:** 'I race the local roundy round and work on anything with bolts.'



15

18

### Nick Zappitelli

**Position:** Field Technical Sales

**Background:** Zappitelli joined Actron (a Bosch brand) tech support in 2001 as an account support specialist supporting CARQUEST from 2005 to 2008, conducting training and product forums. He served as account manager for buy to use accounts from 2008 to 2010 and as account support specialist for Balkamp/NAPA from 2010 to 2011, becoming account manager for Mac Tools and Cornwell Tools. Since 2012 he has served as a Technical Sales Specialist for Balkamp/NAPA.

**Certification:** Various ASE certifications

**In my spare time:** 'I love music and DJ on weekends. I also have an Italian Radio program supporting the Italian community. I love my Cleveland Indians and believe the Ohio State marching band is the best in the land. Go Buckeyes!'



16

### Lee Brewer

**Position:** Field Technical Sales

**Background:** Brewer has spent more than 17 years in the automotive industry. He was a District Sales Manager with a major tool distributor for 15 years, winning ROY four times. Duties included organizing shows, clinics and other types of training. He was also a mobile distributor for two years.

**Certifications:** Procut Installer and Trainer, NAPA ASE and Autotech

**In my spare time:** 'I was raised on a military base and moved all around the country. I'm now married with two children and am an avid racer and love all racing from Go-carts to NASCAR. Hobbies? Fishing, golf and my favorite, an 1800cc supercharged Waverunner!'

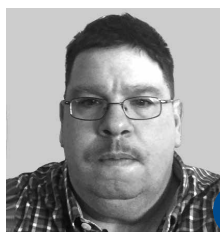

17

### Chris Ellington

**Position:** Field Technical Sales

**Background:** Ellington has more than 26 years in the automotive industry and has owned and operated an import specialist repair shop with a focus on drivability and performance. He has organized and taught drivability clinics for the past six years and still repairs and reprograms automobiles today to maintain and increase his knowledge on the subjects at hand.

**Certification:** American Honda Master Tech and ASE Master Tech

**In my spare time:** 'Turbo anything is my motto'



19

### Chris Hınca

**Position:** Field Technical Sales

**Background:** Hınca has worked in the automotive industry for more than 30 years. Previously he has worked as a technician, service manager and technical trainer, specializing in diagnostics, air conditioning diagnosis/repair and ECU reprogramming.

**Certification:** ASE Certified Technician, OTC diagnostics trainer focusing on Domestic vehicles, Air Conditioning and Reflash/Reprogramming

**In my spare time:** 'I'm an avid outdoorsman, a certified SCUBA diver, hockey coach and trail runner.'



20

### Brett Sanelli

**Position:** Field Technical Sales

**Background:** Sanelli has more than 22 years of experience in the tool industry. Previously, he spent more than 13 years at a major power tool manufacturer focusing on growing its tool business.

**Certification:** MACS Certified Proctor

**In my spare time:** I enjoy fishing, hunting and spending time with my college sweetheart Sabrina and six animals.'

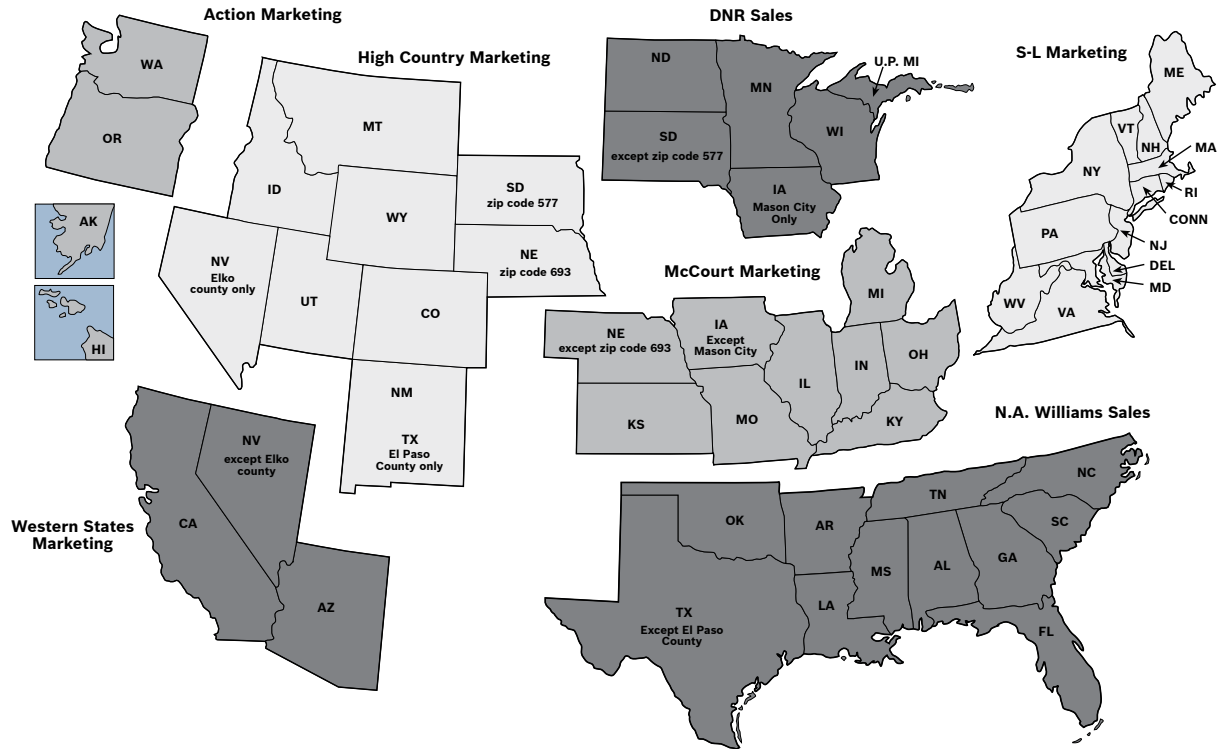

**David Jones 602-574-5734 (Bosch National Technical Sales Manager)**

|                                    |                     |   |
|------------------------------------|---------------------|---|
| Action Marketing                   | Phone: 503-581-9006 | Email: action@actmktg.com                 |
| High Country Marketing             | Phone: 801-233-0007 | Email: sales@high-country-marketing.com   |
| Western States Marketing           | Phone: 714-421-4975 | Email: rstronk@westernstatesmarketing.com |
| DNR Sales, Inc.                    | Phone: 952-829-1844 | Email: cs@dnrsales.com                    |
| S-L Marketing Specialists, Inc.    | Phone: 973-472-0382 | Email: sales@slmarketing.com              |
| McCourt Marketing Group            | Phone: 866-956-4664 | Email: sales@mccourtmail.com              |
| N.A. Williams Tech Sales & Service | Phone: 855-236-8244 | Email: techsales@nawilliams.com           |

Brands in the AA-AS Aftermarket portfolio: Bosch (Wheel Service, Diagnostics), OTC, Robinair, TIF and Autoboss.

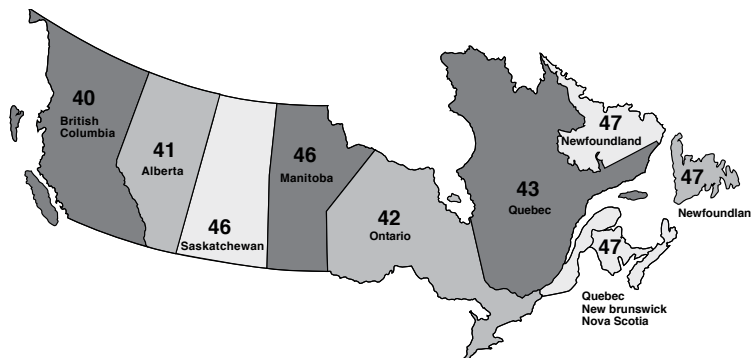

**John Mills 416-566-6704 (Field Technical Sales Canada)**

|   |                     |  |
|---|---------------------|--|
| British Columbia Area 40 (OTC, Robinair, Bosch Diagnostics)                   | Phone: 604-313-2274 | Email: ericbarnsley@shaw.ca              |
| British Columbia Area 40 (Wheel Service only)                                 | Phone: 604-614-3724 | Email: liam@caballero.ca                 |
| Alberta Area 41   | Phone: 780-906-4100 | Email: cdss4100@gmail.com                |
| Ontario West Area 42  | Phone: 519-754-5785 | Email: robgrinton@rogers.com             |
| Quebec Area 43  | Phone: 514-346-2223 | Email: jydelfosse@equipmentsdelfosse.com |
| Manitoba and Saskatchewan Area 46   | Phone: 780-906-4100 | Email: cdss4100@gmail.com                |
| Atlantic Provinces NB, NS, PEI, NF Area 47 (OTC, Robinair, Bosch Diagnostics) | Phone: 647-774-9274 | jaymclennan@gmail.com                    |
| Ontario East Area   | Phone: 519-754-5785 | Email: robgrinton@rogers.com             |

Brands in the AA-AS Aftermarket portfolio: Bosch (Wheel Service, Diagnostics), OTC, Robinair, TIF and Autoboss.



# Special Tools

## MAKE MORE MONEY FOR YOU

Save time, tempers, labor, parts and money with OTC tools built to do special jobs better, faster and easier. These and many other OTC special tools will pay for themselves on only a few jobs. Ask your dealer for OTC tools to fit your problem jobs.

### SAVE TEMPERS WITH FLEX WRENCHES

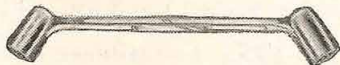

Sockets are extra deep, hot forged with thin straight walls for maximum clearance. Flex over any position within 180° radius of the handle. Sizes from 3/8" to 1".

### FLARE NUT WRENCHES



Hex openings provide a better bite and prevent turning corners on soft brass nuts necessary on fuel, oil and vacuum lines. Made of alloy steel, fully heat-treated—chrome plated finish. Sizes from 3/8" to 1 1/8".

### SAVE MONEY WITH FORD-MERCURY TRANSMISSION BUSHING & OIL SEAL PULLER AND INSTALLING SET No. 400

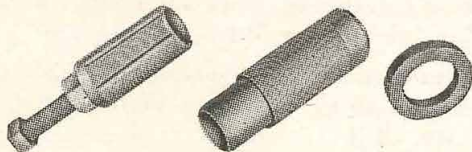

Fits all 1949-1952 Ford or Mercury Models. Takes only 15 minutes to remove and accurately install both Bushing and Oil Seal. Make money with this OTC Time Saver.

Booklet describes complete line of special and standard OTC tools.

## OWATONNA TOOL COMPANY

305 CEDAR STREET . . . OWATONNA, MINNESOTA

April, 1954

### SAVE PARTS WITH NEW UNIVERSAL THREAD CHASER No. 897

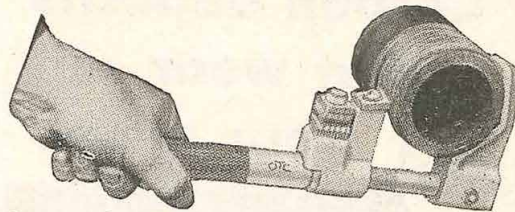

Restores battered damaged or crossed threads—eliminates machining. Adjusts quickly from 1 1/2" to 5" diameter. Six chaser dies have 16 thread pitches from 4 to 24.

### SAVE TIME WITH OTC HYDRAULIC KING-PIN PUSHER

Do king-pin jobs easy in minutes with the 17 1/2 Ton Power-Twin. No hammering—no damaged parts—no torque. King-Pin jobs bring good profits at flat rates . . . pay for tool on a few jobs.

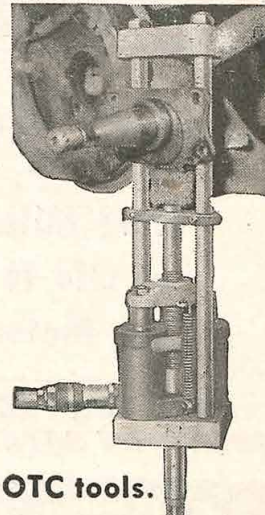

# LIFETIME LIFTING FROM OTC

## OTC'S LINE UP OF JACKS WITH LIFETIME WARRANTY

### 1532A TWO TON ALUMINUM RACING JACK

- Perfect for use with performance cars that have low ground clearance
- Two speed design reaches full height in just 5 pumps
- 2-piece handle, and light-weight aircraft grade aluminum construction
- Rubber saddle protects vehicles and prevents slipping
- ASME-PASE-2014 compliant

### 1728 HIGH-LIFT TRANSMISSION JACK

- 1,000-lb capacity lifts from 34 1/2" to 75"
- Air-assist eases effort with hydraulic precision control
- Tilts 50° forward, 20° backward and 10° sideways

### 5078 HIGH-LIFT HEAVY-DUTY TRANSMISSION JACK

- Lifts from 41 1/2" to 65"
- Includes adapter for Allison 500 and 600 transmissions
- 2,000-lb capacity for truck and bus transmissions

### 5130 DRIVEMASTER™ DRIVELINE LIFT

- Low-profile lifting range from 6" to 30"
- Includes differential adapter for versatility
- Additional commercial auxiliary box adapter available

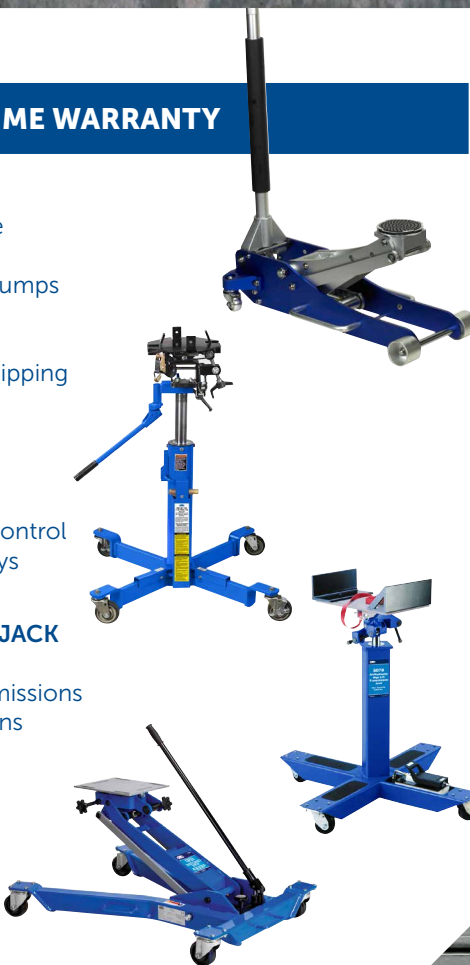

# GRIPOMATIC *Exclusively an* OTC PULLER

## Engineered for DEPENDABILITY

1. Patented linkage gives automatic, positive, non-slip grip.
2. Bolts act as safety link.
3. Quickly adjustable for length.
4. High alloy steel screw and head.
5. Power Pitch screw — 32% more power.
6. High alloy, drop forged, heat-treated jaws — thinner, stronger, safer.
7. Self-centering dog point forcing screw.
8. Sizes for all needs — up to 50 ton capacity.

ASK YOUR SUPPLY HOUSE or  
write for Industrial Bulletin

**OWATONNA TOOL CO.**

357 Cedar Street  
OWATONNA, MINN.

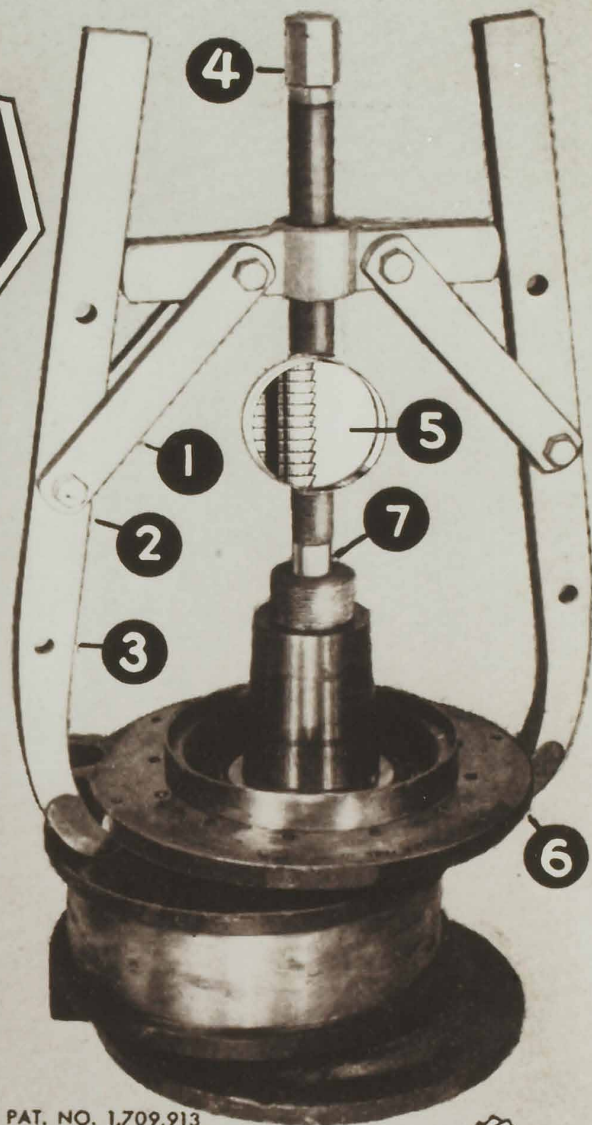

PAT. NO. 1,709,913

Removing a Bearing  
Cage — one of many  
pulling jobs made easy  
with a GRIPOMATIC.

*Handy McKanick*

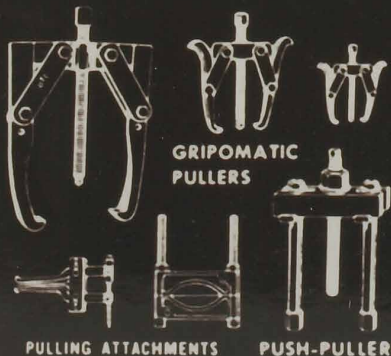

PULLING ATTACHMENTS

PUSH-PULLERS

# OTC

## TOOLS

for MACHINE  
MAINTENANCE

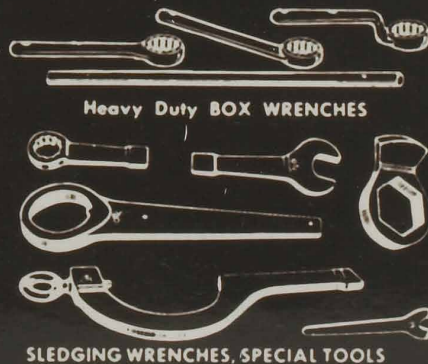

Heavy Duty BOX WRENCHES

SLEDGING WRENCHES, SPECIAL TOOLS

A VINTAGE AD FROM THE 1930s. LEARN MORE ABOUT OTC'S PROUD  
HERITAGE ON PAGE'S 38 & 39.



# WINNER TAKES AN ENCORE

More OTC Encore diagnostic systems in the hands of technicians means more cars fixed faster every day.

**We're giving away one free Encore every day through December 31, 2016. Enter for a chance to win.**

[OTCTOOLS.COM/WIN-ENCORE](http://OTCTOOLS.COM/WIN-ENCORE)



# WE'VE GOT YOU COVERED

When you choose and commit to OTC, a brand in the Bosch Automotive Service Solutions portfolio, we commit to bringing you the utmost level of service and support. We strive to bring best-in-class levels of support that ensures that your trust is never compromised.

## ASE Certified Technical Support

Experienced agents with multilingual support consist of multilevel ASE certified professionals. Agents receive OEM Factory Certification and multilevel network, software and hardware certifications and are able to remotely troubleshoot issues.

## Customer Service

Over 1,600 years combined customer service experience working with dealers, retail customers and service centers. Multilingual support.

## OTCparts.com

Locate and order your replacement parts for OTC tools and equipment.

## Service Center Network

Nationwide coverage with more than 200 service centers provides convenience for service & maintenance for OTC, Robinair, and Bosch Wheel Service.

## RepairTRACK

Control and manage your repairs with selfservice features, all online repairtrack.bosch-automotive.com. Obtain warranty and service information on all Bosch, OTC, and Robinair products.

## OTC Online Product Information & Registration:

[www.otctools.com](http://www.otctools.com)

Service & Technical Support:  
1-800-533-6127

Email: [tech@otctools.com](mailto:tech@otctools.com)

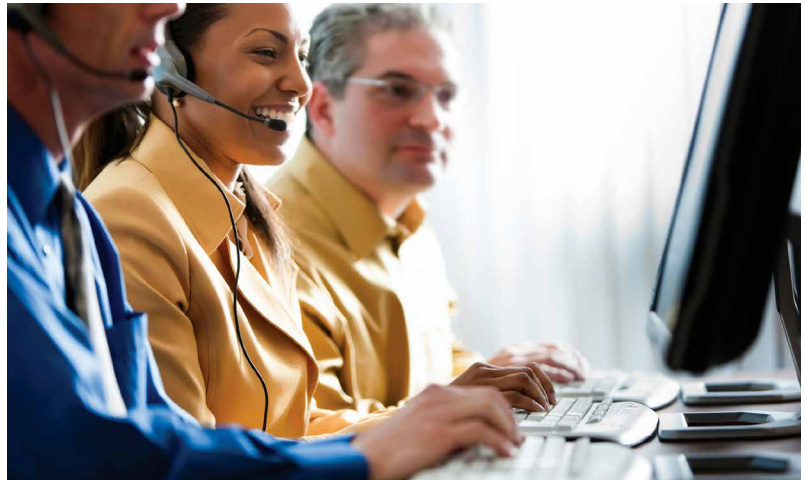

# All makes and models heavy-duty coverage

[boschdiagnostics.com/pro](http://boschdiagnostics.com/pro)

**The best heavy-duty coverage in North America.  
Try it at [boschdiagnostics.com/pro](http://boschdiagnostics.com/pro)**

Fix heavy-duty trucks faster with Bosch ESI[truck]. The all makes/models HD scan tool covers all the big and small manufacturers. One tool, every truck, engine, transmission and brake module.

**Request  
a demo in  
your shop**



**BOSCH**  
Invented for life

# OTC

BOSCH AUTOMOTIVE SERVICE SOLUTIONS INC.  
28635 MOUND ROAD  
WARREN, MI 48092 USA

TECH SERVICES

PHONE 800 533 6127  
FAX 800 955 8329

CUSTOMER SERVICE

PHONE 800 533 6127  
FAX 800 283 8665

[www.otctools.com](http://www.otctools.com)